

HARYANA RAIL INFRASTRUCTURE DEVELOPMENT CORPORATION LIMITED

(A Joint Venture Govt. of Haryana and Ministry of Railways)

Plot no.143, Railtel Tower, Sector-44, Floor/ Room number: 5th floor, City: Gurugram, Zip code: 122003, Country: INDIA

Telephone: +91 9311478893, E-mail: horc.etendering@gmail.com, Website: www.hridc.co.in

Tender No.: HORC/HRIDC/C-4/2022

Date: 12.01.2023

Reference: Specific Procurement Notice dated 04.11.2022.

CORRIGENDUM NO. 3

Name of Work: C-4: Composite Contract package in connection with New BG Railway Line of HORC project for:

- (i) Design & Construction of Twin Tunnel using NATM and Cut & Cover method from km 24.880 to km 29.580;
- (ii) Design & Installation of Ballastless Track (excluding supply of rails) from km 24.856 to km 29.680;
- (iii) Detailed Design, Supply, Installation, Testing & Commissioning of General Electrical Services including Supply, Erection, Testing and Commissioning of 11kV HT/LT Power and Control Cable Network, GIS Substation (11/0.433) kVA, Tunnel lighting system, etc. from km 24.880 to km 29.680;
- (iv) Design & Construction of Embankment, Bridges and other miscellaneous works from km 12.00 to km 18.00

S. No.	Tender Document Part / Section/ Clause No.	Description of Existing Clause	Modified Description of Existing Clause / New Clause
1.	Name of Work	C-4: Composite Contract package in connection with New BG Railway Line of HORC project for: (i) Design & Construction of Twin Tunnel using NATM and Cut & Cover method from km 24.880 to km 29.580; (ii) Design & Installation of Ballastless Track (excluding supply of rails) from km 24.856 to km 29.680; (iii) Detailed Design, Supply, Installation, Testing & Commissioning of General Electrical Services including Supply, Erection, Testing and Commissioning of 11kV HT/LT Power and Control Cable Network, GIS Substation (11/0.433) kVA, Tunnel lighting system, etc. from km 24.880 to km 29.680;	C-4: Composite Contract package in connection with New BG Railway Line of HORC project for: (i) Design & Construction of Twin Tunnel using NATM and Cut & Cover method from km 24.850 to km 29.580; (ii) Design & Installation of Ballastless Track (excluding supply of rails) from km 24.843 to km 29.680; (iii) Detailed Design, Supply, Installation, Testing & Commissioning of General Electrical Services including Supply, Erection, Testing and Commissioning of 11kV HT/LT Power and Control Cable Network, GIS Substation (11/0.433) kVA, Tunnel lighting system, etc. from km 24.843 to km 29.680;

S. No.	Tender Document Part / Section/ Clause No.	Description of Existing Clause	Modified Description of Existing Clause / New Clause
		(iv) Design & Construction of Embankment, Bridges and other miscellaneous works from km 12.00 to km 18.00	(iv) Design & Construction of Embankment, Bridges and other miscellaneous works from km 12.00 to km 18.00
2.	Part 1, Section II, TDS, Sub-Clause ITT 7.2	<p>Add the following at the end of Para 7.2: Site visit with the Employer’s Representative will be conducted on the date and time specified below. Date: 24.11.2022 Time: 1100 hrs. IST Tenderers who wish to participate in site visit on the given date should assemble at the location given below: Nuh Toll Plaza at KMP Expressway & Sohna-Nuh Road (NH 248A crossing) Haryana Country: India For coordination regarding Site visit, Tenderers may contact: Sh. Amarendra Singh Kundu, AM/Civil/Plg. /HRIDC Telephone: +91 7015249184 The costs of visiting the Site shall be at the Tenderer’s own expense.</p>	<p>Add the following at the end of Sub-Clause 7.2 <i>The Tenderer must obtain for themselves information related to site conditions, traffic, location, surroundings, climate, hydrology, meteorological conditions, weather data, availability of power, water, other utilities for construction, access and approach roads to the Site, handling and storage of materials, Waste disposal, applicable laws and regulations and any other matter considered relevant and necessary by them required for submitting their Tender and performance of all of its obligations in accordance with the requirements of Tender Documents.</i> Site visit with the Employer’s Representative will be conducted on the date and time specified below. Date: 24.11.2022 Time: 1100 hrs. IST Tenderers who wish to participate in site visit on the given date should assemble at the location given below: Nuh Toll Plaza at KMP Expressway & Sohna-Nuh Road (NH 248A crossing) Haryana Country: India For coordination regarding Site visit, Tenderers may contact: Sh. Amarendra Singh Kundu, AM/Civil/Plg. /HRIDC Telephone: +91 7015249184 The costs of visiting the Site shall be at the Tenderer’s own expense.</p>

S. No.	Tender Document Part / Section/ Clause No.	Description of Existing Clause	Modified Description of Existing Clause / New Clause
3.	Part 1, Section IV, Tender Forms, Appendix B to Financial Part: Price Schedule 'A'	Appendix B to Financial Part: Price Schedule	The existing Appendix B to Financial Part: Price Schedules is replaced and annexed as “ Attachment 1 ” of this Corrigendum No. 3.
4.	BQQ Excel Sheet – Price Schedule	Price Schedule-MS Excel file for quoting rate against each Schedule	The existing Price Schedule-MS Excel file for quoting rate against each Schedule is replaced through this Corrigendum No. 3
5.	Part 2, Employer’s Requirements, Section VII-1: General, Clause 3, Relevant Documents		Add the following at the end of Sub-Clause 3: <i>All relevant RDSO Standards/drawings required by the Contractor for performance of its obligations under the Contract shall be obtained by the Contractor at their own cost from the office of RDSO. RDSO drawings can also be purchased online from RDSO website.</i>
6.	Part 2, Employer’s Requirements, Section VII-1: General, Clause 10.2	The contractor shall perform all billing processes through the software-based billing system as and when introduced by HORC. The Contractor shall also introduce appropriate Project Management Systems during the project execution phase.	The Contractor shall perform all billing processes through the software-based billing system as and when introduced by HORC <i>free of cost</i> . The Contractor shall also introduce appropriate Project Management Systems during the project execution phase.
7.	Part 2, Employer’s Requirements, Section VII-2: Functional (Civil & BLT)	Section VII- 2: Employer’s Requirements (ER) – Functional (Civil & BLT)	The existing Section VII- 2: Employer’s Requirements (ER) – Functional (Civil & BLT) is replaced and annexed as Attachment 2 of this Corrigendum No. 3
8.	Part 2, Employer’s Requirements, Section VII-3: Design – (Civil and BLT), Minimum Requirement of the DDC’s Organizational Structure,	Minimum Requirement of the DDC’s Organizational Structure	“Minimum Requirement of the DDC’s Organizational Structure” is replaced and annexed as Attachment 3 of this Corrigendum No. 3.

S. No.	Tender Document Part / Section/ Clause No.	Description of Existing Clause	Modified Description of Existing Clause / New Clause
9.	Corrigendum No. 2, S. No. 31, Part 2, Employer's Requirements, Section VII-3: Construction – (Civil and BLT), Attachment C-1	The existing “ Attachment C-1: Minimum Organisation Structure Required ” is revised and annexed as Attachment 3 of this Corrigendum No. 2.	The existing “Attachment C-1: Minimum Organisation Structure Required” in Corrigendum No. 2 is revised and annexed as Attachment 4 of this Corrigendum No. 3.
10.	Corrigendum No. 2, S. No. 32, Part 2, Employer's Requirements, Section VII-3: Construction – (Civil and BLT), Attachment C-2	The existing “ Attachment C-2: Minimum Qualification & Experience of Project Personnel ” is revised and annexed as Attachment 3 of this Corrigendum No. 2.	The existing “ Attachment C-2: Minimum Qualification & Experience of Project Personnel ” in Corrigendum No. 2 is revised and annexed as Attachment 4 of this Corrigendum No. 3.
11.	Corrigendum No. 2, S. No. 33, Part 2, Employer's Requirements, Section VII-3: Construction – (Civil and BLT), Attachment C-3	The existing “ Attachment C-3: Minimum Resources required for the Project- Plants & Equipment ” is revised and annexed as Attachment 3 of this Corrigendum No. 2.	The existing “ Attachment C-3: Minimum Resources required for the Project- Plant & Equipment ” in Corrigendum No. 2 is revised and annexed as Attachment 4 of this Corrigendum No. 3.
12.	Part 2, Employer's Requirements, Section VII-5: Outline Design Specifications (ODS)– Civil & BLT, Chapter 1, Introduction, First Para	This part lays down the specifications/criteria for design of civil structures i.e. tunnels (NATM and Cut & Cover), permanent ventilation shafts, ballastless track, bridges, embankments, retaining walls and other civil structures.	This part lays down the specifications/criteria for design of civil structures i.e. tunnels (NATM and Cut & Cover), permanent ventilation shafts, <i>construction cum utility shaft</i> ballastless track, bridges, <i>embankments and</i> other civil structures.
13.	Part 2, Employer's Requirements, Section VII-5: Outline Design Specifications (ODS)–	The Employer shall furnish following documents to the Contractor: - a) Plan and L-section of the main line b) Conceptual GAD of bridges	The Employer shall furnish following documents to the Contractor: - a) <i>Conceptual</i> Plan and L-section of the main line b) Conceptual GAD of bridges

S. No.	Tender Document Part / Section/ Clause No.	Description of Existing Clause	Modified Description of Existing Clause / New Clause
	Civil & BLT, Sub-Clause 2.2, Employer's Inputs	c) Conceptual layout plan for tunnel d) Geotechnical Interpretive Report (GIR) for tunnel e) Design Basis Report (DBR) for tunnel f) Geo-technical investigation reports for tunnel and bridges	c) Conceptual layout plan for tunnel d) <i>Preliminary</i> Geotechnical Interpretive Report (GIR) for tunnel e) Design Basis Report (DBR) for tunnel f) <i>Preliminary</i> Geo-technical investigation reports for tunnel and bridges
14.	Part 2, Employer's Requirements, Section VII-5: Outline Design Specifications (ODS)– Civil & BLT, Sub-Clause 2.3, Design Life,	a) Tunnels works The design life of all tunnel structures shall be 120 years.	a) Tunnels works The design life of all tunnel structures <i>including, portals, permanent ventilation shafts and construction cum utility shaft</i> shall be 120 years.
15.	Part 2, Employer's Requirements, Section VII-5: Outline Design Specifications (ODS)– Civil & BLT, Sub-Clause 2.3, Design Life,	c) Retaining Wall The design life of retaining walls shall be 100 years.	<i>Deleted</i>
16.	Part 2, Employer's Requirements, Section VII-5: Outline Design Specifications (ODS)– Civil & BLT, Sub-Clause 2.8.4	Horizontal and vertical alignment has been given in the Final Alignment Drawings. Proposed Right of Way (ROW) has also been marked on the Alignment Drawings. The Contractor should check the feasibility of alignment at site and may propose minor modification, if required.	Horizontal and vertical alignment has been given in the <i>Conceptual Plan and Longitudinal Section</i> Drawings. Proposed Right of Way (ROW) has also been marked on the Alignment Drawings. The Contractor <i>shall</i> check the feasibility of alignment at site and may propose minor modifications, if required.
17.	Part 2, Employer's Requirements, Section VII-5: Outline Design Specifications (ODS)– Civil & BLT, Sub-Clause 2.8.6	Exposure conditions shall be considered as 'moderate' for design of all type of structures/bridges.	Exposure conditions shall be considered as 'moderate' for design of all type of structures/bridges. <i>However, in case of waterway bridges carrying sewage/waste water, the exposure condition shall be considered "Severe"</i> .

S. No.	Tender Document Part / Section/ Clause No.	Description of Existing Clause	Modified Description of Existing Clause / New Clause
18.	Part 2, Employer's Requirements, Section VII-5: Outline Design Specifications (ODS)– Civil & BLT, Sub-Clause 2.8.8	The data like bridge length, size, barrel length, type of crossing, highest flood level (HFL), total waterway and indicative span configuration etc. in respect of the proposed road/ waterway bridges has been shown in the conceptual GAD of the bridges. While designing the bridges, it shall be obligatory that in case of parallel section, the total bridge length, box opening and/or HFL for an individual bridge for HORC project shall not be less than that of the corresponding KMP/DFC bridge. Also, the span configuration for the proposed bridges shall match the span configuration of the corresponding KMP/DFC bridge, to the maximum extent possible, to avoid obstruction and to bring the abutment/piers in line with the existing abutment/piers. Deviation from above shall be in consultation and with approval of the Engineer.	Data like bridge length, size, barrel length, type of crossing, highest flood level (HFL), total waterway and indicative span configuration etc. in respect of the proposed road/ waterway bridges has been shown in the conceptual GAD of the bridges. <i>The bridge opening (horizontal and vertical) shall not be less than the indicated in the Conceptual GADs.</i>
19.	Part 2, Employer's Requirements, Section VII-5: Outline Design Specifications (ODS)– Civil & BLT, Sub-Clause 2.8.9	Precast RCC drains shall be designed for drainage of storm water from embankments between existing KMP expressway and HORC embankment.	<i>Backfill on approaches of Minor Bridge shall be placed in accordance with IRS Substructure Code. Approaches of Major Bridges (i.e. bridges having span equal to or more than 12.2m) shall be provided transition system as per RDSO report GE:R-50 as shown in Sketch No. GC-HRIDC-SK-GEN-019</i>
20.	Part 2, Employer's Requirements, Section VII-5: Outline Design Specifications (ODS)– Civil & BLT, Sub-Clause 2.8.10	In case of pile foundation, bored cast in-situ concrete piles of diameter 1.2m shall be provided.	In case of pile foundation, bored cast in-situ concrete piles of diameter 1.2m shall be <i>designed</i> .
21.	Part 2, Employer's Requirements, Section VII-5: Outline Design Specifications (ODS)–	Inspection platform all-round the abutment caps/pier caps shall be provided along with access ladder.	Inspection platform all-round the abutment caps/pier caps shall be <i>designed</i> along with access ladder.

S. No.	Tender Document Part / Section/ Clause No.	Description of Existing Clause	Modified Description of Existing Clause / New Clause
	Civil & BLT, Sub-Clause 2.8.11		
22.	Part 2, Employer's Requirements, Section VII-5: Outline Design Specifications (ODS)– Civil & BLT, Sub-Clause 2.8.12	Trolley refuge on bridges shall be provided as per provisions of IRSOD.	Trolley <i>refuges</i> on bridges shall be <i>designed</i> as per provisions of IRSOD/IRPWM.
23.	Part 2, Employer's Requirements, Section VII-5: Outline Design Specifications (ODS)– Civil & BLT, Sub-Clause 2.8.14	Protection of embankment on approaches of bridges shall be by CC blocks of suitable sizes, over consolidated gravel bed of minimum thickness of 150 mm, encased in cast in-situ RCC grid frames of suitable cross section having opening size of approximately 1.75m x 1.75m, for a length of 30m on both sides for major bridges and 15m on both sides for RCC boxes. The above protection works shall be provided with toe wall at the end of slope. Adequate drainage arrangement shall be provided in protection works.	<i>The</i> embankment on approaches of bridges shall be <i>protected</i> by CC blocks of suitable sizes, over consolidated gravel bed of minimum thickness of 150 mm, encased in cast in-situ RCC grid frames of suitable cross section having opening size of approximately 1.75m x 1.75m, for a length of 30m on both sides for major bridges and 15m on both sides for RCC boxes. Toe wall <i>shall be designed</i> at the end of <i>embankment</i> slope as shown in Tender drawings.
24.	Part 2, Employer's Requirements, Section VII-5: Outline Design Specifications (ODS)– Civil & BLT, Sub-Clause 2.8.15	Inspection steps (1m wide) on either side of formation shall be provided with CC of M20 grade at all bridges.	Inspection steps (1m wide) on either side of formation shall be <i>designed</i> with CC of M20 grade at all bridges.
25.	Part 2, Employer's Requirements, Section VII-5: Outline Design Specifications (ODS)– Civil & BLT, Sub-Clause 2.8.17	Necessary provisions for OHE mast shall be made on piers of bridges having multiple CG/ OWG spans.	Necessary provisions for OHE mast (2 x 25 kV) shall be kept on bridges.
26.	Part 2, Employer's Requirements, Section VII-5: Outline Design	Precast retaining walls shall be designed upto 2m height above ground level. Beyond 2m height, cast in-situ retaining	<i>Deleted</i>

S. No.	Tender Document Part / Section/ Clause No.	Description of Existing Clause	Modified Description of Existing Clause / New Clause
	Specifications (ODS)– Civil & BLT, Sub-Clause 2.8.18	wall may be used. Reinforced Earth (RE) wall shall not be permitted.	
27.	Part 2, Employer’s Requirements, Section VII-5: Outline Design Specifications (ODS)– Civil & BLT, Sub-Clause 2.8.19	Precast CC coping shall be provided over the return wall, wing wall & retaining wall with minimum thickness of 75mm at the edge and 100mm at the centre. It shall project 75mm beyond the wall thickness on either side.	Precast CC coping shall be provided over the return wall & wing wall <i>of bridges</i> with minimum thickness of 75mm at the edge and 100mm at the centre. It shall project 75mm beyond the wall thickness on either side.
28.	Part 2, Employer’s Requirements, Section VII-5: Outline Design Specifications (ODS)– Civil & BLT, Sub-Clause 2.8.20	NP-4 pipe of 450mm diameter, conforming to IS 458, shall be designed at about 500m interval throughout the alignment in embankments having fill heights upto 5m. In embankments having fill heights more than 5m precast RCC box of 500mmx500mm clear size shall be designed for the purpose of future utilities. RCC pipe shall be designed for appropriate installation conditions as per IS-783, according to the fill height.	NP-4 pipe of 450mm diameter, conforming to IS 458 <i>in embankments</i> shall be designed <i>for</i> fill heights upto 5m <i>including ballast cushion</i> . In embankments having fill heights more than 5m, precast RCC box of 500mmx500mm clear size shall be designed for the purpose of future utilities. RCC pipe shall be designed for appropriate installation conditions as per IS-783, according to the fill height.
29.	Part 2, Employer’s Requirements, Section VII-5: Outline Design Specifications (ODS)– Civil & BLT, <i>New</i> Sub-Clause 2.8.21		Add new Sub-Clause 2.8.21 at the end of Sub-Clause 2.8.20 <i>Compensated Ruling Gradient for the section is 1 in 150.</i>
30.	Part 2, Employer’s Requirements, Section VII-5: Outline Design Specifications (ODS)– Civil & BLT, Sub-Clause 3.1	General The Outline Design Criteria hereto provide minimum standards that are to govern the design of NATM tunnel, Cut & Cover tunnel, Permanent Ventilation Shafts, portals and other Permanent Works. The Outline Design Criteria shall be read in conjunction with DBR and Outline Construction Specifications (Civil and BLT) where appropriate. Wherever in contract documents any term provides for consent, concurrence, no-objection or agreement of the	General The Outline Design Criteria hereto provide minimum standards that are to govern the design of NATM tunnel, Cut & Cover tunnel, Permanent Ventilation Shafts, <i>construction cum utility shaft</i> portals and other Permanent Works. The Outline Design Criteria shall be read in conjunction with DBR and Outline Construction Specifications (Civil and BLT) where appropriate.

S. No.	Tender Document Part / Section/ Clause No.	Description of Existing Clause	Modified Description of Existing Clause / New Clause
		Employer or the Engineer, the same shall mean and denote consent concurrence or agreement in writing (even if not so expressly stated).	Wherever in contract documents any term provides for consent, concurrence, no-objection or agreement of the Employer or the Engineer, the same shall mean and denote consent concurrence or agreement in writing (even if not so expressly stated).
31.	Part 2, Employer's Requirements, Section VII-5: Outline Design Specifications (ODS)– Civil & BLT, Sub-Clause 3.3	<p>The horizontal and vertical alignments of the HORC Project are given in the Tender drawings as listed in Employer's Requirements, Section VII-8, Tender drawings and documents.</p> <p>The Contractor shall design the tunnel works to these alignments. However, subject to the provisions of the Contract, changes to the given alignments may be permitted to suit the specific characteristics of his design as per Sub-Clause 2.7 of Employer's Requirements – Functional(Civil and BLT), at no extra cost to the Employer subject to prior approval of the Employer. While fixing the design alignment of tunnel, due consideration for lateral and vertical clearances as per IRSOD on curves shall be given.</p>	<p>The horizontal and vertical alignments of the HORC Project are given in the Tender drawings as listed in Employer's Requirements, Section VII-8, Tender drawings and documents.</p> <p>The Contractor shall design the tunnel works to these alignments. However, subject to the provisions of the Contract, <i>minor</i> changes to the given alignments may be permitted to suit the specific characteristics of his design as per Sub-Clause 2.7 of Employer's Requirements – Functional(Civil and BLT), at no extra cost to the Employer subject to prior approval of the Employer. While fixing the design alignment of tunnel, due consideration for lateral and vertical clearances as per IRSOD on curves shall be given.</p>
32.	Part 2, Employer's Requirements, Section VII-5: Outline Design Specifications (ODS)– Civil & BLT, Sub-Clause 3.4	<p>TUNNEL CROSS SECTION</p> <p>The cross section of tunnel shall be determined in accordance with DBR. The cross section of the tunnel shall ensure provision of space for associated structures and equipment required for operation and maintenance of the tunnel.</p>	<p>TUNNEL CROSS SECTION</p> <p>The cross section of tunnel shall be determined in accordance with <i>Design Basis Report (DBR) provided under List of Documents, Section VII-8: Tender Drawings and Documents, Part 2 -Employer's Requirements.</i> The cross section of the tunnel shall ensure provision of space for associated structures and equipment required for operation and maintenance of the tunnel.</p>
33.	Corrigendum 2, S, No. 35, Part 2, Employer's Requirements, Section	<p>4.1 General</p> <p>The Contractor shall be responsible for determining for his design purposes the Geology and the Geotechnical</p>	<p>4.1 General</p> <p>4.1.1 The Contractor shall be responsible for determining for his design purposes the Geology and the Geotechnical</p>

S. No.	Tender Document Part / Section/ Clause No.	Description of Existing Clause	Modified Description of Existing Clause / New Clause
	VII-5: Outline Design Specifications (ODS)– Civil & BLT, Sub-Clause 4.1	parameters of the sub-surface strata along the route. Geotechnical Investigations have been carried out by the Employer and the <i>Preliminary</i> Geotechnical Investigations Reports are given in Employer’s Requirements, Section VII-8, Tender drawings and documents for information only. These shall be confirmed and supplemented, if considered necessary, by the Contractor by way of additional boreholes. <i>Minimum depth of confirmatory / additional boreholes below tunnel invert level shall be 1.5 times the excavation width /depth of the tunnel whichever is more.</i>	parameters of the sub-surface strata along the route. Geotechnical Investigations have been carried out by the Employer and the Preliminary Geotechnical Investigations Reports are given in Employer’s Requirements, Section VII-8, Tender drawings and documents for information only. <i>The Contractor shall confirm geotechnical parameters independently through confirmatory boreholes. Additional boreholes, wherever required for design, shall also be carried out at his own cost.</i> Minimum depth of confirmatory / additional boreholes below tunnel invert level shall be 1.5 times the excavation width /depth of the tunnel whichever is more. <i>4.1.2 If the Contractor intends to carry out additional ground investigation from the surface, beyond the limits of the worksite, he shall make his own arrangements with land owners and occupiers for the necessary access. He shall not assume that such access will necessarily be granted, although the Engineer will provide assistance where it appears that this would be beneficial.</i>
34.	Part 2, Employer’s Requirements, Section VII-5: Outline Design Specifications (ODS)– Civil & BLT, Chapter 5	DESIGN OF CUT & COVER TWIN TUNNEL AND PERMANENT VENTILATION SHAFTS	DESIGN OF CUT & COVER TWIN TUNNEL, PERMANENT VENTILATION SHAFTS AND CONSTRUCTION CUM UTILITY SHAFT
35.	Part 2, Employer’s Requirements, Section VII-5: Outline Design Specifications (ODS)– Civil & BLT, Sub-Clause 5.1	GENERAL PRINCIPLES The Contractor shall use design methods for the analysis of the permanent ventilation shafts that take into account, but not limited to: a. the method of construction, including temporary works;	GENERAL PRINCIPLES 5.1.1 The Contractor shall use design methods for the analysis of <i>Cut & Cover tunnel</i> , the permanent ventilation shafts <i>and construction cum utility shaft</i> that take into account, but not limited to: a. the method of construction, including temporary works;

S. No.	Tender Document Part / Section/ Clause No.	Description of Existing Clause	Modified Description of Existing Clause / New Clause
		<p>b. the ground/structure interaction, including the effects of temporary works; c. ground pressure redistribution and bending moment redistribution; d. short and long term heave and settlement; e. Groundwater loading, backfill and other imposed loading, if any.</p> <p>For the purposes of assessing ground pressures the shafts shall be considered as effectively a rigid box structure subject to earth pressure at rest. Temporary Ground Support shall be designed in accordance with the requirements of Chapter 6. In preparing his designs and method statements the Contractor shall carry out his own assessment of the adequacy of the available geotechnical information, and shall indicate where he considers such information to be deficient having regard to the particular works or activities to which the design or method statement relates. The Contractor shall at his own expense conduct further oil investigations where his designs or method statements identify that it is necessary or prudent to do so to enable him to identify all foreseeable circumstances which may affect the execution of the works and to ensure that there is no likelihood of meeting unexpected conditions of a critical nature.</p> <p>If the Contractor intends to carry out additional ground investigation from the surface, beyond the limits of the worksite, he shall make his own arrangements with landowners and occupiers for the necessary access. He shall not assume that such access will necessarily be granted,</p>	<p>b. the ground/structure interaction, including the effects of temporary works; c. ground pressure redistribution and bending moment redistribution; d. short and long term heave and settlement; e. Groundwater loading, backfill and other imposed loading, if any.</p> <p>For the purposes of assessing ground pressures the shafts shall be considered as effectively a rigid box structure subject to earth pressure at rest. Temporary Ground Support shall be designed in accordance with the requirements of Chapter 6. <i>5.1.2 Preliminary Geotechnical investigation reports given in Section VII-8: Tender Drawings and Documents are indicative in nature. The Contractor shall confirm geotechnical parameters independently through confirmatory boreholes. Additional boreholes, wherever required for design, shall also be carried out at his own cost.</i></p> <p>5.1.3 If the Contractor intends to carry out additional ground investigation from the surface, beyond the limits of the worksite, he shall make his own arrangements with landowners and occupiers for the necessary access. He shall not assume that such access will necessarily be granted,</p>

S. No.	Tender Document Part / Section/ Clause No.	Description of Existing Clause	Modified Description of Existing Clause / New Clause
		<p>although the Engineer will provide assistance where it appears that this would be beneficial.</p> <p>The design life required shall be obtained by the use of durable materials, corrosion protection, resistance to or avoidance of wear etc.</p>	<p>although the Engineer will provide assistance where it appears that this would be beneficial.</p> <p>5.1.4 The design life required shall be obtained by the use of durable materials, corrosion protection, resistance to or avoidance of wear etc.</p>
36.	Part 2, Employer's Requirements, Section VII-5: Outline Design Specifications (ODS)– Civil & BLT , Sub-Clause 5.2 ,Design Principles	a) the geology along the length and depth of the cutting;	a) the geology along the length and depth of the <i>Cut & Cover tunnel/shafts</i> ;
37.	Part 2, Employer's Requirements, Section VII-5: Outline Design Specifications (ODS)– Civil & BLT , Sub-Clause 5.2	b) the hydrology and the permeabilities of the strata encountered along the length of the cutting;	b) the hydrology and the permeabilities of the strata encountered along the length of the <i>Cut & Cover tunnel/shafts</i> ;
38.	Part 2, Employer's Requirements, Section VII-5: Outline Design Specifications (ODS)– Civil & BLT , Sub-Clause 5.2	e) any particular difficulties that special plant might meet with in respect of access, clearances and working space;	e) any particular difficulties that special plant & <i>machinery</i> might meet with in respect of access, clearances and working space;
39.	Part 2, Employer's Requirements, Section VII-5: Outline Design Specifications (ODS)– Civil & BLT , Sub-Clause 5.10	<p>WATERPROOFING</p> <p>The grade of concrete, treatment of construction joints, areas of slab pours and external protection shall be chosen such that the required standard of waterproofing can be achieved and maintained. Materials for expansion joints, caulking etc.</p>	Sub-Clause 5.10 is replaced and annexed as Attachment 5 of this Corrigendum No. 3

S. No.	Tender Document Part / Section/ Clause No.	Description of Existing Clause	Modified Description of Existing Clause / New Clause
		shall have acceptable fire performance for use on an underground railway line.	
40.	Part 2, Employer's Requirements, Section VII-5: Outline Design Specifications (ODS)– Civil & BLT , Sub-Clause Chapter 6, Title	TEMPORARY GROUND SUPPORT SYSTEM & OTHER REQUIREMENTS FOR EXCAVATION TO CUT & COVER TWIN TUNNEL, PERMANENT VENTILATION SHAFTS AND CONSTRUCTION CUM UTILITY SHAFT	TEMPORARY GROUND SUPPORT SYSTEM & OTHER REQUIREMENTS FOR EXCAVATION TO CUT & COVER TWIN TUNNEL, PERMANENT VENTILATION SHAFTS CONSTRUCTION CUM UTILITY SHAFT AND CONSTRUCTION CUM UTILITY SHAFT
41.	Part 2, Employer's Requirements, Section VII-5: Outline Design Specifications (ODS)– Civil & BLT , Sub-Clause 7.1	<p>7.1.1 In preparing his designs and method statements the Contractor shall carry out his own assessment of the adequacy of the available geological and geotechnical information, and shall indicate where he considers such information to be deficient having regard to the particular works or activities to which the design or method statement relates.</p> <p>7.1.2 The Contractor shall at his own expense conduct further soil/rock investigations in additions to investigations where his designs or method statements identify that it is necessary or prudent to do so to enable him to identify all foreseeable circumstances which may affect the execution of the works and to ensure that there is no likelihood of meeting unexpected conditions of a critical nature.</p> <p>7.1.3 If the Contractor intends to carry out additional ground investigation from the surface, beyond the limits of the worksite, he shall make his own arrangements with land owners and occupiers for the necessary access. He shall not assume that such access will necessarily be granted, although the Engineer will provide assistance where it appears that this would be beneficial.</p>	<p><i>7.1.1 Preliminary Geotechnical investigation reports given in Section VII-8: Tender Drawings and Documents are indicative in nature. The Contractor shall confirm geotechnical parameters independently through confirmatory boreholes. Additional boreholes, wherever required for design, shall also be carried out at his own cost.</i></p> <p>7.1.2 Deleted</p> <p>7.1.3 If the Contractor intends to carry out additional ground investigation from the surface, beyond the limits of the worksite, he shall make his own arrangements with land owners and occupiers for the necessary access. He shall not assume that such access will necessarily be granted, although the Engineer will provide assistance where it appears that this would be beneficial.</p>
42.	Part 2, Employer's Requirements, Section VII-5: Outline Design	NATM Main Drive in Soil	NATM Main Drive in Soil

S. No.	Tender Document Part / Section/ Clause No.	Description of Existing Clause	Modified Description of Existing Clause / New Clause
	Specifications (ODS)– Civil & BLT , Sub-Clause 7.2.1	In some portion of the works, it is expected that tunnel is to be constructed in soil portion specifically from CH 26000 m to CH 28880 m. The excavation sequences for heading, benching and invert shall be designed in such a manner that the deformations inside the tunnel shall be limited to the design deformations considered in fixing the excavation profile. The design calculations for the support system shall be carried out with standard software available in the market, e.g. FLAC, PLAXIS, RS2 etc. The design submitted for the same shall also indicate for adjustment for support system requirement with respect to the instrumented data gathered during execution.	<i>NATM tunnel shall be constructed in soil portion approximately from CH 26000 m to CH 28880 m. The excavation sequences for heading, benching and invert shall be designed in such a manner that the deformations inside the tunnel shall be limited to the design deformations considered in fixing the excavation profile. The design calculations for the support system shall be carried out with standard software available in the market, e.g. FLAC, PLAXIS, RS2 etc. The design submitted for the same shall also indicate for adjustment for support system requirement with respect to the instrumented data gathered during execution.</i>
43.	Part 2, Employer’s Requirements, Section VII-5: Outline Design Specifications (ODS)– Civil & BLT , Sub-Clause 7.3.3, Ground movements, Second Para	During the Preliminary Design phase, all existing structures that may be influenced by construction of the works shall be investigated to establish allowable settlement criteria for each structure or group of structures. Establishment of an appropriate zone of influence shall be accepted as 50m either side of the tunnel centre-line or the base of the excavation plus a spread of 45° to the horizontal in areas where structures are located whichever is more.	During the Preliminary Design phase, all existing structures that may be influenced by construction of the works shall be investigated to establish allowable settlement criteria for each structure or group of structures. Establishment of an appropriate zone of influence shall be accepted as 50m either side of the tunnel centre-line or the base of the excavation plus a spread of 45° to the horizontal in areas where structures are located whichever is more. <i>However, 765 kV EHT transmission tower located at chainage 28265 m which is adjacent to up line tunnel shall be protected by appropriately designed sheet piling/soldier piling/micro piling. The design shall be got approved by the utility owner.</i>
44.	Part 2, Employer’s Requirements, Section VII-5: Outline Design Specifications (ODS)–	DESIGN OF FINAL TUNNEL LINING	DESIGN OF SECONDARY LINING

S. No.	Tender Document Part / Section/ Clause No.	Description of Existing Clause	Modified Description of Existing Clause / New Clause
	Civil & BLT , Sub-Clause 7.4,		
45.	Part 2, Employer's Requirements, Section VII-5: Outline Design Specifications (ODS)– Civil & BLT , Sub-Clause 7.4.1	<p>General</p> <p>The Contractor shall prepare and submit to The Engineer for his consent a detailed design including calculations schedules and drawings for final lining for all kind of geological variations expected to be encountered along the tunnel alignment. Design of lining shall be carried out in accordance with provisions of DBR.</p>	<p>General</p> <p>The Contractor shall prepare and submit to The Engineer for his consent a detailed design including calculations schedules and drawings for <i>secondary</i> lining for all kind of geological variations expected to be encountered along the tunnel alignment. Design of lining shall be carried out in accordance with provisions of DBR.</p>
46.	Part 2, Employer's Requirements, Section VII-5: Outline Design Specifications (ODS)– Civil & BLT , Sub-Clause 7.4.2	<p>Cracking of Concrete</p> <p>Anti-crack reinforcement shall be provided in all walls and slabs more than 250 mm thick to distribute cracking arising from shrinkage, early thermal and temperature effects. Reinforcement on each face in each direction should be at least 0.125% of the concrete cross-sectional area for grades 415 and above. In addition, spacing between the bars should not be greater than 150 mm.</p> <p>Generally, pairing of bars and more than one layer of bars is not preferred for such structures. It is preferred that smaller diameter bars in any direction are placed at closer intervals to prevent early thermal and shrinkage cracks.</p>	<p>Cracking of Concrete</p> <p>Anti-crack reinforcement shall be provided in all walls and slabs more than 250 mm thick to distribute cracking arising from shrinkage, early thermal and temperature effects. Reinforcement on each face in each direction should be at least 0.125% of the concrete cross-sectional area for <i>Fe 500D</i> and above. In addition, spacing between the bars should not be greater than 150 mm.</p> <p>Generally, pairing of bars and more than one layer of bars is not preferred for such structures. It is preferred that smaller diameter bars in any direction are placed at closer intervals to prevent early thermal and shrinkage cracks.</p>
47.	Part 2, Employer's Requirements, Section VII-5: Outline Design Specifications (ODS)– Civil & BLT , Sub-Clause 8.3	8.3 SPECIFICATIONS FOR NATM INSTRUMENTS	The entire Sub-Clause 8.3, SPECIFICATIONS FOR NATM INSTRUMENTS is deleted
48.	Part 2, Employer's Requirements, Section VII-5: Outline Design Specifications (ODS)–	8.4 EXECUTION AND MONITORING	The entire Sub-Clause 8.4, EXECUTION AND MONITORING is deleted.

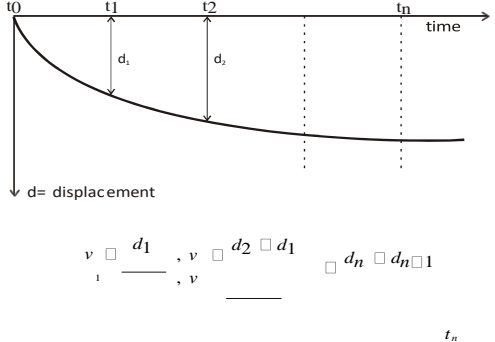
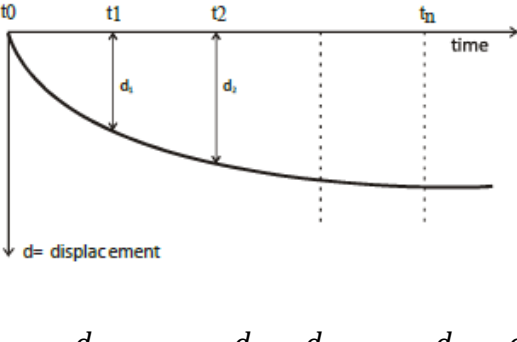
S. No.	Tender Document Part / Section/ Clause No.	Description of Existing Clause	Modified Description of Existing Clause / New Clause
	Civil & BLT , Sub-Clause 8.4		
49.	Part 2, Employer's Requirements, Section VII-5: Outline Design Specifications (ODS)– Civil & BLT , Sub-Clause 10.4.2 Displacement Velocity, Fig. 10.7	 <p style="text-align: center;">Fig. 10 .7: Definition of Control Limits for Displacement Velocities</p>	 <p style="text-align: center;">Fig. 10 .7: Definition of Control Limits for Displacement Velocities</p>
50.	Part 2, Employer's Requirements, Section VII-5: Outline Design Specifications (ODS)– Civil & BLT , Sub-Clause 10.4.3 Trend Lines	<p>Trend Lines</p> <p>Control Limits for trend lines are defined in terms of:</p> <p style="text-align: center;">— □ <i>advance</i></p> <p>With □ = Increase in displacement <i>Advance</i> = corresponding face advance</p>	<p>Trend Lines</p> <p>Control Limits for trend lines are defined in terms of:</p> <p style="text-align: center;">δ — advance</p> <p>With δ = Increase in displacement <i>Advance</i> = corresponding face advance</p>
51.	Part 2, Employer's Requirements, Section VII-5: Outline Design Specifications (ODS)–	<p>General</p> <p>This part lays down criteria for design of formation in embankment.</p>	<p>General</p> <p>This part lays down criteria for design of formation in embankment/<i>cutting</i>.</p>

S. No.	Tender Document Part / Section/ Clause No.	Description of Existing Clause	Modified Description of Existing Clause / New Clause
	Civil & BLT, Sub-Clause 12.1		
52.	Part 2, Employer's Requirements, Section VII-5: Outline Design Specifications (ODS)– Civil & BLT, Sub-Clause 12.2, e)	e) Design of hume pipe (NP-4)/RCC box crossings for utilities	e) Design of hume pipe (NP-4) <i>of 450 mm dia/</i> Precast RCC box <i>of size 500 mm x500 mm for crossings future utilities</i>
53.	Part 2, Employer's Requirements, Section VII-5: Outline Design Specifications (ODS)– Civil & BLT, Sub-Clause 12.3, d)	d) Width of berm shall be adequate to suit the mechanical compaction of earth with heavy rollers. However, berm width shall be kept minimum 2m.	d) Width of berm shall be adequate to suit the mechanical compaction of earth with heavy rollers. However, berm width shall be kept minimum 2m <i>on banks and 4 m in cuttings.</i>
54.	Part 2, Employer's Requirements, Section VII-5: Outline Design Specifications (ODS)– Civil & BLT, Sub-Clause 12.3, f)	f) Width of berm shall be adequate to suit the mechanical compaction of earth with heavy rollers. However, berm width shall be kept minimum 2m.	<i>Deleted</i>
55.	Part 2, Employer's Requirements, Section VII-5: Outline Design Specifications (ODS)– Civil & BLT, Sub-Clause 12.3, g)	g) Blanket material shall conform to RDSO Guidelines.	<i>Deleted</i>
56.	Part 2, Employer's Requirements, Section VII-5: Outline Design Specifications (ODS)– Civil & BLT, Sub-Clause 12.3, h), ii.	ii. In the double track section, the longitudinal drain between two tracks shall not be provided. However, in case of parallel Section, if toe of the new embankment overlaps the toe of the existing KMP embankment, longitudinal CC drain of suitable capacity, for satisfactory evacuation of storm water,	ii. In the double track section, the longitudinal drain between two tracks shall not be provided <i>outside station yards.</i>

S. No.	Tender Document Part / Section/ Clause No.	Description of Existing Clause	Modified Description of Existing Clause / New Clause
		shall be designed between new HORC embankment and existing KMP embankment.	
57.	Part 2, Employer's Requirements, Section VII-5: Outline Design Specifications (ODS)– Civil & BLT, Sub-Clause 12.3, h), v .		<p>Add the following as para v. Existing para v. and vi. are renumbered as vi and vii respectively.</p> <p><i>In cuttings, a system of catch water drains of adequate capacity on both sides shall be designed to intercept the surface runoff of adjoining areas from entering into the cutting and to lead the surface runoff safely away from cutting. In addition, longitudinal side drains of adequate capacity on both sides of formation shall be designed to cater to the surface runoff from slopes and formation. Typical Section of cuttings has been shown in Tender drawings.</i></p>
58.	Part 2, Employer's Requirements, Section VII-5: Outline Design Specifications (ODS)– Civil & BLT, Sub-Clause 12.3, h), v .	v . All the drains shall be lined with CC of M20 grade.	vi . All cast-in-situ drains shall be of concrete of M20 grade.
59.	Part 2, Employer's Requirements, Section VII-5: Outline Design Specifications (ODS)– Civil & BLT, Sub-Clause 12.3, h), vi .	vi . All the drains shall slope towards the nearest culvert or natural low ground or natural outlets existing nearby where the water shall be discharged with appropriately designed outfall arrangement duly consented by the Engineer.	vii . Generally, all the drains shall slope towards the nearest culvert or natural low ground or natural outlets existing nearby where the water shall be discharged with appropriately designed outfall arrangement duly consented by the Engineer.
60.	Part 2, Employer's Requirements, Section VII-5: Outline Design Specifications (ODS)– Civil & BLT, Sub-Clause 12.3.1	Trolley refuge shall be designed as shown in tender drawing. It shall be provided at 100m center to center on both Up and Dn tracks in a staggered manner.	12.3.1 Trolley refuge shall be designed as shown in tender drawing. It shall be provided at 400m center to center on each Up and Dn tracks in a staggered manner.

S. No.	Tender Document Part / Section/ Clause No.	Description of Existing Clause	Modified Description of Existing Clause / New Clause
61.	Part 2, Employer's Requirements, Section VII-5: Outline Design Specifications (ODS)– Civil & BLT, Sub-Clause 12.3.1, vii	vii. NP-4 pipe of 450mm diameter, conforming to IS 458, shall be provided at about 500m interval throughout the alignment in embankments having fill heights upto 5m. In embankments having fill heights more than 5m precast RCC box of 500mmx500mm clear size shall be provided for the purpose of future utilities. Installation conditions for the pipe shall be designed as per the IS-783, according to the fill height.	12.3.2 NP-4 pipe of 450mm diameter, conforming to IS 458, shall be provided at about 500m interval throughout the alignment in embankments having fill heights upto 5m <i>including ballast cushion</i> . In embankments having fill heights more than 5m precast RCC box of 500mmx500mm clear size shall be provided for the purpose of future utilities. Installation conditions for the pipe shall be designed as per the IS-783, according to the fill height.
62.	Part 2, Employer's Requirements, Section VII-5: Outline Design Specifications (ODS)– Civil & BLT, Sub-Clause 13.1.	<p>General</p> <p>The Bridges in HORC Project comprises of simply supported Prestressed U-slab / Steel Composite Girders with RCC sub-structure with open/deep foundation and RCC Box Bridges/Culverts.</p> <p>Minimum Centre to Centre distance between two tracks has been kept as 5.3m according to IRSOD (BG).</p>	<p>General</p> <p>The Bridges in HORC Project comprises of simply supported Prestressed U-slab / Steel Composite Girders with RCC sub-structure with open/deep foundation and RCC Box Bridges/Culverts.</p> <p>Minimum Centre to Centre distance between two tracks has been kept as 5.3m according to IRSOD (BG).</p> <p><i>All the bridges shall be provided with bridge number plaque, painting of HFL and bridge boards, where required. Approach embankment of minor bridge approaches shall be provided protection measures for a length of 15m on either side as shown in Tender drawings. Approach embankment of major bridge approaches shall be provided protection measures for a length of 30m on either side as shown in Tender drawings</i></p>
63.	Part 2, Employer's Requirements, Section VII-5: Outline Design Specifications (ODS)– Civil & BLT, Sub-Clause 13.2.3, last 3 paras	Standard RDSO drawing for box culvert shall be followed to the maximum extent. If standard RDSO drawing is not available for desired sizes/fill height, box shall be designed by the Contractor. However, thickness and reinforcement of the box shall not be less than the closest available box size & fill height of RDSO drawing.	Standard RDSO drawing for box culvert shall be followed. If standard RDSO drawing is not available for desired sizes/fill height, box shall be designed by the Contractor. However, thickness and reinforcement of the box shall not be less than the closest available box size & fill height of RDSO drawing.

S. No.	Tender Document Part / Section/ Clause No.	Description of Existing Clause	Modified Description of Existing Clause / New Clause
		<p>RDSO box culvert for double track are available upto 2m fill height. In case of higher fill heights, the size and reinforcement of box shall not be less than the that of RDSO box for single track with fill height of minimum 2m more than actual fill height.</p> <p>Any variation from the above, if required due to site constraints shall be adopted after the prior approval of the Engineer.</p>	<p>RDSO box culvert for double track are available upto 2m fill height. In case of higher fill heights, the size and reinforcement of box shall not be less than the that of RDSO box for single track with fill height of minimum 2m more than actual fill height.</p> <p>Any variation from the above, if required due to site constraints shall be adopted after the prior approval of the Engineer.</p>
64.	Part 2, Employer's Requirements, Section VII-5: Outline Design Specifications (ODS)– Civil & BLT, Sub-Clause 13.3.1.	13.3.1 Railway Bridges with Steel/PSC superstructure	13.3.1 Railway Bridges.
65.	Part 2, Employer's Requirements, Section VII-5: Outline Design Specifications (ODS)– Civil & BLT, Sub-Clause 13.3.1, v.	v. Side pathway with hand railing shall be provided on steel superstructure bridges on outer side of Up & Down track.	v. Side pathway with hand railing shall be provided on steel superstructure bridges on outer side of Up & Down track <i>as per RDSO drawing No. CBS-0046 (Typical Plan of Side Pathway in Standard Composite Girders).</i>
66.	Part 2, Employer's Requirements, Section VII-5: Outline Design Specifications (ODS)– Civil & BLT, Sub-Clause 13.3.1, xi, xii.		<p>Add new para xi & xii at the end of para x</p> <p><i>xi Height gauge for road – under – bridges shall be as per RDSO drawing no. RDSO/M-0001. If RDSO drawing is not available, the Contractor shall design height gauge for the required span considering applicable loading. However, the section of height gauge shall not be less than RDSO drawing No. RDSO/M-0001.</i></p> <p><i>xii Minimum depth of foundation of waterway bridges shall be scour depth plus 1.75m below the bed level.</i></p>

S. No.	Tender Document Part / Section/ Clause No.	Description of Existing Clause	Modified Description of Existing Clause / New Clause
67.	Part 2, Employer's Requirements, Section VII-5: Outline Design Specifications (ODS)– Civil & BLT, Sub-Clause 13.3.2, ii.	ii. Size of the Box openings (minimum required) has been shown in the conceptual GADs. Height of box shown includes clear height and wearing coarse of 150mm. Overall height of box may vary as per site requirement and actual road/ground profile. Any variation, due to site constraints, shall be done with the consent of the Engineer	ii. Size of the Box openings (minimum required) has been shown in the conceptual GADs. Height of box shown includes clear height and wearing coarse of 150mm. Overall height of box may vary as per site requirement and actual road/ground profile.
68.	Part 2, Employer's Requirements, Section VII-5: Outline Design Specifications (ODS)– Civil & BLT, Sub-Clause 13.3.2 iv	iv. The clear inner dimension of the box shall cater to the requirements of type of crossing. The height of box shall include the thickness of wearing coarse provided inside the box.	iv. <i>Top of bottom slab of RCC box shall not be kept above the natural ground level beside the road. However, road level and vertical clearance above the road shall be maintained as shown in Tender drawings. Any variation due to site conditions as mentioned above shall be got approved from the Engineer.</i>
69.	Part 2, Employer's Requirements, Section VII-5: Outline Design Specifications (ODS)– Civil & BLT, Sub-Clause 13.3.2, vi.	vi. All waterway bridges shall be protected by a well-designed flooring system. The concrete floor shall be protected by curtain wall at upstream side and drop wall at downstream side, wherever applicable.	vi. All waterway bridges shall be protected by a well-designed flooring system. The concrete floor shall be protected by curtain wall at upstream side and drop wall at downstream side. <i>Minimum depth of the curtain wall and drop wall shall be scour depth plus 1.75m below the bed level</i>
70.	Part 2, Employer's Requirements, Section VII-5: Outline Design Specifications (ODS)– Civil & BLT, Sub-Clause 13.3.2, vii.	vii. Other Requirements: a. All RUBs shall be provided with 1m wide walkway on one side of the carriageway. b. The approaches / approach ramps to the RUBs shall be of concrete of minimum M25 grade. c. Suitable height gauges shall be provided on both sides of RUBs as per RDSO Drawing No. RDSO/M-0001.	vii Other Requirements: a. <i>Deleted.</i> b. <i>The approach roads to the RUBs shall be provided from RCC box to ROW of HORC for the width equal to clear opening of RCC box in concrete of M35 grade.</i> c. <i>Height gauge for road – under – bridges shall be as per RDSO drawing no. RDSO/M-0001. If RDSO drawing is not available, the Contractor shall design</i>

S. No.	Tender Document Part / Section/ Clause No.	Description of Existing Clause	Modified Description of Existing Clause / New Clause
		<p>d. Crash Barriers / medians / footpaths / railings shall be provided as per the requirements of IRC Codes.</p> <p>e. Inspection Steps shall be provided wherever required.</p> <p>f. Provision for lighting shall be kept in the design of bridges.</p> <p>g. Provision for signages shall be kept on both side of RUBs.</p> <p>h. Suitable drainage system including sump and discharge arrangement (as required) and protection works / ancillary works shall be designed.</p> <p>Detailed Design criteria for of the Bridges shall be as per the below mentioned Outline design specifications criteria .</p>	<p><i>height gauge for the required span considering applicable loading. However, the section of height gauge shall not be less than RDSO drawing No. RDSO/M-0001.</i></p> <p>d. Crash Barriers / medians / footpaths / railings shall be provided as per the requirements of IRC Codes.</p> <p>e. Inspection Steps shall be provided wherever required.</p> <p>f. <i>Deleted.</i></p> <p>g. Provision for signages shall be kept on both side of RUBs.</p> <p>h. <i>Deleted.</i></p> <p>Detailed Design criteria for of the Bridges shall be as per the below mentioned Outline design specifications criteria.</p>
71.	Part 2, Employer's Requirements, Section VII-5: Outline Design Specifications (ODS)– Civil & BLT, Sub-Clause 13.4.1, a).	<p>a) CLEARANCES FOR ROAD TRAFFIC</p> <p>Vertical clearance for road traffic shall generally be 100 mm more than the clearance specified in Clause 104.4.2 of IRC: 5.</p> <p>General Arrangement Drawings at road crossings shall be approved by the owning authorities/stake holders.</p>	<p>a) CLEARANCES FOR ROAD TRAFFIC</p> <p>Vertical clearance for road traffic shall generally be 100 mm more than the clearance specified in Clause 104.4.2 of IRC: 5 <i>or as per Conceptual GAD, whichever is more.</i></p> <p>General Arrangement Drawings at road crossings shall be approved by the owning authorities/stake holders.</p>
72.	Part 2, Employer's Requirements, Section VII-5: Outline Design Specifications (ODS)– Civil & BLT, Sub-Clause 13.4.3, vi, (b),	(b) Rail Structure Interaction (LWR Forces)	The entire para “ (b) Rail Structure Interaction (LWR Forces) ” is deleted.

S. No.	Tender Document Part / Section/ Clause No.	Description of Existing Clause	Modified Description of Existing Clause / New Clause
73.	Part 2, Employer's Requirements, Section VII-5: Outline Design Specifications (ODS)– Civil & BLT, Sub-Clause 13.7, (b)	(b) Piers The effective length of a cantilever pier for the purpose of slenderness ratio calculation will be taken as per IRS-CBC. Ductile detailing is mandatory. The design of pier shall be done as per IRS CBC. In all SLS combinations, pier/column shall remain in compression.	(b) Piers The effective length of a cantilever pier for the purpose of slenderness ratio calculation will be taken as per IRS-CBC. Ductile detailing is mandatory. The design of pier shall be done as per IRS CBC. <i>Shear reinforcement and ductile detailing shall be done as per IRS CBC</i>
74.	Part 2, Employer's Requirements, Section VII-6: Outline Constructions Specifications (OCS)– Civil & BLT,	Section VII-6: Outline Constructions Specifications (OCS) Civil & BLT	The existing Section VII- 7: Employer's Requirements- : Outline Constructions Specifications (OCS) Civil & BLT is replaced and annexed as Attachment 6 of this Corrigendum No. 3
75.	Part 2, Employer's Requirements, Section VII-6: Outline Constructions Specifications (OCS)– Civil & BLT, Chapter 14	Chapter 14: Outline Design Specifications: Retaining Walls	The content of “Chapter 14: Outline Design Specifications: Retaining Walls” stands deleted.
76.	Part 2, Employer's Requirements, Section VII-6: Outline Constructions Specifications (OCS)– Civil & BLT, Sub-Clause 15.9	SPARES The Contractor shall supply fastening system @10% of the total requirement for the permanent works as maintenance spare.	SPARES The Contractor shall supply <i>spare track fastenings and fittings equal to 10%</i> of the total requirement for the permanent works.
77.	Part 2, Employer's Requirements, Section VII-6: Outline Constructions Specifications (OCS)–	Relevant Standards Apart from the basic data and specific requirements listed in the Employer's Requirement, all items of the Works shall be governed by the latest versions of the following codes and specifications as revised/corrected/amended	Relevant Standards Apart from the basic data and specific requirements listed in the Employer's Requirement, all items of the Works shall be governed by the latest versions of the following codes and

S. No.	Tender Document Part / Section/ Clause No.	Description of Existing Clause	Modified Description of Existing Clause / New Clause
	Civil & BLT, Sub-Clause 16.2, first para,	(with latest correction slip) till the date of approval of design/drawings by the Engineer. In case of contradiction in various codal provisions, the order of precedence shall be as follows:- i. Specific provisions in the Employer's Requirements. ii. IRS Codes and specifications iii. IS Codes iv. IRC Codes and specifications v. International Codes	specifications as revised/corrected/amended (with latest correction slip) till the date of <i>opening of the Tender</i> . In case of contradiction in various codal provisions, the order of precedence shall be as follows:- i. Specific provisions in the Employer's Requirements. ii. IRS Codes and specifications iii. IS Codes iv. IRC Codes and specifications v. International Codes
78.	Part 2, Employer's Requirements, Section VII-7: General Electrical Services	Section VII-7: General Electrical Services	The existing Section VII- 7: Employer's Requirements (ER)-General Electrical Services is replaced and annexed as Attachment 7 of this Corrigendum No. 3
79.	Corrigendum 2, S. No. 49, Attachment 5: Section VII-8, Tender Drawings and Documents	Section VII-8A: Tender Drawings	The existing Tender drawings of Corrigendum No. 2 which have been revised and new Tender drawings which have been added to Section VII-8A: Tender drawings are annexed as Attachment 8 of this Corrigendum No. 3.
80.	Part 2, Section VII-8, Employer's Requirements-Tender Drawings and Documents, Design Basis Report, Sub Clause 9.6.		Add new sub clause 9.6 at the end of sub clause 9.5. <i>9.6 Future Road Traffic Load</i> <i>A load of 20 kN/m² shall be considered over top of the tunnel for future road traffic.</i>
81.	Part 2, Section VII-8, Employer's	12.3.3 Exhaust Fan & Overhead System [G1]	12.3.3 Exhaust Fan & Overhead System [G1]

S. No.	Tender Document Part / Section/ Clause No.	Description of Existing Clause	Modified Description of Existing Clause / New Clause
	Requirements-Tender Drawings and Documents, Design Basis Report, Sub Clause 12.3.3	<p>An overhead system for rail and exhaust fan load is considered to be acting on inner lining of the tunnel. These systems are directly fixed by anchors. A suitable load on 7.2kN acting apart 1m shall be applied to inner lining.</p> <p>An overhead system is considered as a single vertical concentrated load with a value of 33.7 KN placed 1m horizontal from the centerline of the tunnel on the left side of the arch.</p> <p>A load factor of 1.25 is considered as per as per IRS – CBC 1997.</p>	<p>An overhead system for exhaust fan load is considered to be acting on inner lining of the tunnel. These systems are directly fixed by anchors. A suitable load on 7.2kN acting apart 1m shall be applied to inner lining.</p> <p>An overhead system is considered as a single vertical concentrated load with a value of 3.0 kN placed 1m horizontal from the centerline of the tunnel on the left side of the arch.</p> <p>A load factor of 1.25 is considered as per as per IRS – CBC 1997.</p>
82.	Part 2, Section VII-8, Employer’s Requirements-Tender Drawings and Documents, Design Basis Report, Sub Clause 13.6.5		<p>Add new Sub-Clause 13.6.5 at the end of Sub-Clause 13.6.4 13.6.5 Future Road Traffic Load [G2]</p> <p><i>A load of 20 kN/m² shall be considered over top of the tunnel for future road traffic.</i></p>
83.	Part 2, Section VII-8, Employer’s Requirements-Tender Drawings and Documents, Design Basis Report, Sub Clause 13.6.6		<p>Add new Sub-Clause 13.6.6 at the end of Sub-Clause 13.6.5. 13.6.6 Exhaust Fan & Overhead System [G1]</p> <p><i>An overhead system for exhaust fan load is considered to be acting on inner lining of the tunnel. These systems are directly fixed by anchors. A suitable load on 7.2kN acting apart 1m shall be applied to inner lining.</i></p> <p><i>An overhead system is considered as a single vertical concentrated load with a value of 3.0 kN placed 1m</i></p>

S. No.	Tender Document Part / Section/ Clause No.	Description of Existing Clause	Modified Description of Existing Clause / New Clause
			<p><i>horizontal from the centerline of the tunnel on the left side of the arch.</i></p> <p><i>A load factor of 1.25 is considered as per as per IRS – CBC 1997</i></p>
84.	Part 2, Section VII-8, Employer’s Requirements-Tender Drawings and Documents, Design Basis Report, Sub Clause 13.7	13.7 Analysis Method of Cut and Cover	<p><i>The existing Sub-Clause 13.7 is renumbered as Sub-Clause 13.9</i></p> <p><i>13.9 Analysis Method of Cut and Cover</i></p>
85.	Part 2, Section VII-8, Employer’s Requirements-Tender Drawings and Documents, Design Basis Report, Sub Clause 13.7		<p>Add the following as Sub-Clause 13.7 at the end of Sub-Clause 13.6.6.</p> <p><i>13.7 Applied load cases</i></p> <p><i>The applied load cases will be following:</i></p> <p><i>G1 Self weight (Includes Fan & Overhead System Weight)</i></p> <p><i>G2 Earth pressure & Future Road Traffic Load</i></p> <p><i>G3 Weight of Fill</i></p> <p><i>Q1 Temperature Loads (Winter and Summer)</i></p> <p><i>E1 Earthquake loads</i></p> <p><i>The general formats for combinations of actions for the ultimate and serviceability limit states as given in Indian Railway Standard- Concrete Bridge Code 1997 (IRS-CBC), Table-12</i></p>

S. No.	Tender Document Part / Section/ Clause No.	Description of Existing Clause	Modified Description of Existing Clause / New Clause
			<p><i>The partial factors for actions and combination of actions are taken from IRS Concrete Bridge Code 1997.</i></p> <p><i>The load combinations used for the calculation are listed in the following tables.</i></p>
86.	Part 2, Section VII-8, Employer's Requirements-Tender Drawings and Documents, Design Basis Report, Sub Clause 13.8		<p>Add new Sub-Clause 13.8 at the end of Sub-Clause 13.7.</p> <p><i>13.8 A layer of PCC of grade M20 150 mm thick shall be provided below bottom slab of the Cut and Cover tunnel.</i></p>
87.	Part 2, Section VII-8, Employer's Requirements-Tender Drawings and Documents, Design Basis Report, Sub Clause 15.	<p>15. Permanent Ventilation Shafts</p> <p>To minimize ventilation requirement four rectangular permanent ventilation shafts at Chainage Km 26+080 and Chainage Km 27+680 has been provided. Size of rectangular ventilation shaft shall be 25m x 12m (clear opening). At the locations of permanent ventilation shafts it is mandatory to provide permanent ventilation shafts shall be lined with RCC and same shall be designed for all the loadings during construction and design life.</p>	<p>15. Permanent Ventilation Shafts</p> <p>15.1 To minimize ventilation requirement four rectangular permanent ventilation shafts at Chainage Km 26+080 and Chainage Km 27+680 have been provided. Size of rectangular ventilation shaft shall be 25m x 12m (clear opening). At the locations of permanent ventilation shafts it is mandatory to provide connecting cross passage with clear opening as shown in Tender drawings. All the permanent ventilation shafts shall be of RCC and shall be designed for all the loadings during construction and design life.</p> <p>15.2 Permanent ventilation shafts shall be designed for all load cases and combination as mentioned in Clause 13 of this DBR. <i>Inspection arrangements of permanent ventilation shafts during service life shall also be designed by the Contractor.</i></p> <p>15.3 <i>Precast /Cast in Situ PSC/RCC roofing system over the shafts with proper ventilation arrangement shall be</i></p>

S. No.	Tender Document Part / Section/ Clause No.	Description of Existing Clause	Modified Description of Existing Clause / New Clause
			<i>designed by the Contractor as per relevant IS Codes/NBC. Each shaft shall be provided with steel access door at natural ground level having sturdy locking arrangement with anti-theft features.</i>
88.	Part 2, Section VII-8, Employer's Requirements-Tender Drawings and Documents, Design Basis Report, Sub Clause 16.	<p>16. Construction cum Utility Shaft A construction cum utility shaft shall be provided at Chainage Km 26+950. The main purpose of construction shaft is to provide multiple faces to expedite the tunnel excavation. At the location of construction cum utility shaft cross passage shall be provided having the same cross-sectional area as the main tunnel. The size of construction shaft may be kept as per requirement of the contractor. Design and construction of construction cum utility shaft shall be carried out by the contractor accordingly.</p>	<p>16. Construction cum Utility Shaft 16.1 A construction cum utility shaft shall be provided at Chainage Km 26+950. The main purpose of construction shaft is to provide multiple faces to expedite the tunnel excavation <i>and to provide access for utilities to the tunnel.</i> At the location of construction cum utility shaft cross passage shall be provided having the same cross-sectional area as the main tunnel. 16.2 <i>Construction cum utility shaft shall be designed for all load cases and combination as mentioned in Clause 13 of this DBR. Inspection arrangements of construction cum utility shaft during service life shall also be designed by the Contractor.</i> 16.3 <i>Precast /Cast in Situ PSC/RCC roofing system over the shaft with proper ventilation arrangement shall be designed by the Contractor as per relevant IS Codes/NBC. Shaft shall be provided with steel access door at natural ground level having sturdy locking arrangement with anti-theft features.</i></p>
89.	Part 2, Section VII-8, Tender Drawings and Documents, VII-8B, Tender Documents, List of Documents, 6.	Geotechnical Investigation Reports No. SR NO. : 544_21-22 Table 4.5: Safe Load Carrying Capacity of normal bored cast in-situ RCC Pile in Soil”	The existing “ Table 4.5: Safe Load Carrying Capacity of normal bored cast in-situ RCC Pile in Soil ” of Geotechnical Investigation Reports No. SR NO. : 544_21-22 is replaced and annexed as Attachment 9 of this Corrigendum No. 3.

S. No.	Tender Document Part / Section/ Clause No.	Description of Existing Clause	Modified Description of Existing Clause / New Clause
	Geotechnical Investigation Reports		
90.	Part 2, Section VII-8, Employer's Requirements-Tender Drawings and Documents, List of Documents, 7. Approved Manufactures/Suppliers List	7. Approved Manufacturer/ Supplier list	The existing "Approved Manufacturer/Suppliers list" is revised and annexed as Attachment 10 of this Corrigendum No. 3.
91.	Part 2, Employer's Requirements, Section VII-9: Appendices, Appendix 10, Sub-Clause 10.14	The contractor shall clear the Site as required by demolishing all buildings, structures (above and below ground such as brick, concrete, steel, etc.) and removing all rubbish as agreed by the Engineer. The Site shall also be cleared of vegetation, trees, stumps roots, etc. Cutting of trees within ROW wherever required for execution of the Works shall be done by the Contractor. Permission for cutting of trees will be obtained by the Employer. Compensatory plantation is not included in the Scope of the Works. All material so cleared from the site shall be disposed off by the Contractor outside the ROW as directed by the Engineer.	The contractor shall clear the Site as required by demolishing all buildings, structures (above and below ground such as brick, concrete, steel, etc.) and removing all rubbish as agreed by the Engineer. <i>If any payment/compensation is payable to the structures owner, the same shall be paid by the Employer to the structures owner.</i> The Site shall also be cleared of vegetation, trees, stumps roots, etc. Cutting of trees within ROW wherever required for execution of the Works shall be done by the Contractor. Permission for cutting of trees will be obtained by the Employer. Compensatory plantation is not included in the Scope of the Works. All material so cleared from the site shall be disposed off by the Contractor outside the ROW as directed by the Engineer.
92.	Part 2, Section VII-9: Appendices, Appendix 10, Sub-Clause 10.19	SITE ACCOMMODATION FOR THE EMPLOYER/ ENGINEER	SITE OFFICE AND RESTING ACCOMMODATION FOR THE EMPLOYER/ ENGINEER Sub-Clause 10.19 is replaced and is annexed as Attachment 11 of this Corrigendum No. 3

S. No.	Tender Document Part / Section/ Clause No.	Description of Existing Clause	Modified Description of Existing Clause / New Clause
93.	Part 2, Employer's Requirements, Section VII-9: Appendices, Appendix 10, Sub-Clause 10.26	<p>Other Related Surveys</p> <p>The Contractor shall be responsible for carrying out validation of any Site data provided by the Employer and any other surveys considered necessary by the Contractor for the execution of the Works. Such surveys may include, but are not limited to, the following:</p> <ul style="list-style-type: none"> a) Topographic Survey b) Utilities Survey including Adjacent Structures and Works with Works Areas c) Environmental Survey 	<p>Other Related Surveys</p> <p>The Contractor shall be responsible for carrying out validation of any Site data provided by the Employer and any other surveys considered necessary by the Contractor for the execution of the Works. Such surveys may include, but are not limited to, the following:</p> <ul style="list-style-type: none"> a) Topographic Survey b) Utilities Survey including Adjacent Structures and Works with Works Areas c) Environmental Survey d) <i>Hydrological/ Hydro-Meteorological Survey</i>
94.	Part 2, Employer's Requirements, Section VII-9: Appendices, Appendix 10, Sub-Clause 10.45.1 (c)	Contractor shall be responsible for relocation/diversion/shifting/modification of all chartered/unchartered utilities infringing the Works.	Contractor shall be responsible for relocation/diversion/shifting/modification of all chartered (<i>except specified otherwise</i>) and unchartered utilities infringing the Works.
95.	Part 2, Employer's Requirements, Section VII-9: Appendices, Appendix, Sub-Clause 10.46.2, ii	<p>ii. Type B – Overground Utility</p> <p>These are various utilities which existed on ground at the time of acquiring the land by the Employer and may affect the execution of the work. The Employer takes the responsibility to dismantle these utilities up to ground level and hand over the land to the Contractor free of these encumbrances. Removal of remaining portion below ground level, wherever required, shall be responsibility of the</p>	<i>Deleted</i>

S. No.	Tender Document Part / Section/ Clause No.	Description of Existing Clause	Modified Description of Existing Clause / New Clause			
		Contractor. The Accepted Contract Amount shall be deemed to include all such works and risks.				
96.	Part 2, Employer's Requirements, Section VII-9: Appendices, Appendix, Sub-Clause 10.46.2, iii	iii. Type C- Underground Utilities These are various charted underground utilities which are existing and Contractor shall consider and take into account the effect of these in his price.	<i>Deleted</i>			
97.	Corrigendum 2, S. No. 56, Part 2, Employer's Requirements, Section VII-9: Appendices, Appendix 12	Appendix 12- Contractor's Site Laboratory/R1	The existing " Appendix 12-Contractor's Site Laboratory/R1 " of Corrigendum No. 2 is revised and annexed as Attachment 12 of this Corrigendum No. 3.			
98.	Part 2, Employer's Requirements, Section VII -9: Appendices, Appendix 13, Sub-Clause 6.2.4, Table, Last Row	<table border="1" data-bbox="562 783 1323 911"> <tr> <td data-bbox="562 783 792 911">Cutting of trees</td> <td data-bbox="792 783 1070 911">Punjab Land Preservation Act, 1900(PLPA, 1900)</td> <td data-bbox="1070 783 1323 911">Forest Department, Haryana</td> </tr> </table>	Cutting of trees	Punjab Land Preservation Act, 1900(PLPA, 1900)	Forest Department, Haryana	<i>Deleted</i>
Cutting of trees	Punjab Land Preservation Act, 1900(PLPA, 1900)	Forest Department, Haryana				
99.	Part 2, Employer's Requirements, Section VII -9: Appendices, Appendix 13, Attachment -5 Safe Work Procedure for Work Near Railway Track, Sub-Clause 2.3 (B)	c) Suitable speed restriction shall be imposed, or Traffic block shall be ensured as required.	c) Suitable speed restriction shall be imposed, or Traffic block shall be ensured as required. <i>The requirement of Traffic and Power Blocks shall be submitted by the Contractor to the Engineer for approval. The Traffic and Power blocks will be finalised in consultation with Delhi Division of Northern Railway. No cost shall be charged for Traffic and Power blocks from the Contractor.</i>			

S. No.	Tender Document Part / Section/ Clause No.	Description of Existing Clause	Modified Description of Existing Clause / New Clause
100.	Part 3, Section IX, Conditions of Contract, Part B: Specific Provisions, PCC, Sub-Clause 1.1.88	“ Variation ” means any change to the works which is instructed as a variation under Clause 13 [Variations and Adjustments].	<p>Following new para is added at the end of Sub-Clause 1.1.88:</p> <p><i>“Conceptual Tender drawings have been furnished in the Contract in good faith and to enable the Contractor to carry out design of the Works. The Contractor shall design the Works in accordance with Employer’s Requirements based on which the Notice shall be issued by the Engineer. No claim shall be entertained from the Contractor for executing the Works as per drawings for which Notice has been given by the Engineer. If any additional opening is required due to agitation by land owners or due to demand by road authority or due to any other reason not attributable to the Contractor after award of the Contract, the same will constitute Variation and shall be dealt with as per the conditions of the Contract. If there is a change in the clear opening area of Road Under Bridges (RUBs) and canal crossings by more than (+/-) 10% over the opening area shown in conceptual Tender drawings due to agitation by land owners or due to demand by road authority or due to any other reason after award of the Contract, the same will constitute Variation and shall be dealt with as per conditions of the Contract”</i></p>

List of Attachments to Corrigendum No. 3

S. No.	Attachment	Description
1.	Attachment 1	Section IV: Tender Forms: Appendix B to Financial Part: Price Schedules/R1
2.	Attachment 2	Section VII 2: Employer's Requirements (ER) – Functional (Civil & BLT)/R1
3.	Attachment 3	Section VII-4: Employer's Requirements-Design (Civil & BLT) MINIMUM REQUIREMENT OF THE DDC'S ORGANIZATIONAL STRUCTURE /R1
4.	Attachment 4	Section VII-4: Employer's Requirements-Construction (Civil & BLT) 1. Attachment C-1/R2: Minimum Organisation Structure Required 2. Attachment C-2/R2: Minimum Qualification & Experience of Project Personnel 3. Attachment C-3/R2: Minimum Resources Required for the Project- Plants & Equipment
5.	Attachment 5	Section VII-7: Employer's Requirements -Outline Construction Specifications (OCS)-Civil & BLT Sub-Clause 5.10)- WATERPROOFING
6.	Attachment 6	Section VII 6: Employer's Requirements – Outline Construction Specifications (OCS)- (Civil & BLT)/R1
7.	Attachment 7	Section VII-7: Employer's Requirements - General Electrical Services/R1
8.	Attachment 8	Section VII-8: Tender Drawings and Documents, Revised and New Drawings
9.	Attachment 9	Section VII-8: Employer's Requirements-Tender Drawings and documents, List of Documents, 6. Geotechnical Investigation Report, Table 4.5: Safe Load Carrying Capacity of normal bored cast in-situ RCC Pile in Soil"/R1 of Geotechnical Investigation Reports No. SR NO.: 544_21-22
10.	Attachment 10	Section VII-8: Tender Drawings and Documents, List of Documents, 7. APPROVED MANUFACTURES/SUPPLIERS LIST/R1
11.	Attachment 11	Section VII-9: Employer's Requirements-Appendices, Appendix – 1, Sub-Clause 10.19, Site Office and Resting Accommodation for the Employer/ Engineer
12.	Attachment 12	Section VII-9: Employer's Requirements-Appendices, Appendix – 12/R1; Contractor's Site Laboratory

Tender No. HORC/HRIDC/C-4/2022
Attachment 1
to
Corrigendum No. 3

Part 1, Section IV, Tender Forms
Appendix B to Financial Part: Price
Schedules/R1

Appendix B to Financial Part: Price Schedules/R1

1 Preamble

1.1. The Price Schedules shall be read in conjunction with the Instructions to Tenderers, the General Conditions, the Particular Conditions and the Employer's Requirements *{General, Functional (Civil and BLT), Design (Civil), Construction (Civil), Outline Design Specifications (ODS)-Civil and BLT, Outline Construction Specifications (OCS)-Civil and BLT, General Electrical Services, Tender drawings and documents and Appendices}* and the Addenda (if any).

1.2. **Schedule 'A'** comprises scope of work to be executed under lump sum contract as detailed in Part 2- Employers' Requirements of Tender Document. *Cost of Schedule 'A' also includes cost of tree cutting for entire package C-4 as per Sub-Clause 10.14 of Appendix 10, Section VII-9: Appendices, Part 2 -Employer's Requirements of Tender Documents. The Tenderer has to quote a single lump sum amount against Schedule 'A'*. Payment to the Contractor will be made in accordance with payment stages/Milestones defined for each Cost Centre detailed in Clause 5.0 below unless otherwise specified in the Contract.

1.3. **Schedule 'B'** - Other civil works:

Schedule 'B' comprises of percentage rate for "Other civil works". The work has to be carried out as per the description of items given in Schedule 'B' and directions of the Engineer. *Cost of design and drawings of all the temporary works, temporary road diversion is deemed to be included in the rates quoted for the relevant item of Schedule 'B' unless otherwise specified in the Contract.* The Tenderer has to quote the percentage Excess (+) or Less (-) over the total Estimated amount of Schedule 'B' *(which is shown as "Estimated Rate" against Schedule 'B' in BOQ2 of MS excel file on e-procurement portal)*. The payment against this Schedule 'B' will be made on the basis of quantities executed, measured and certified. Under this Schedule, the Contractor is required to carry out other civil works, which are not covered in Schedule 'A', as per site requirements and as per the direction of the Engineer.

1.4. **Schedule 'C'** comprises "Item rates for miscellaneous works". Under this Schedule, the Contractor has to undertake items or works not covered in Schedule 'A' or Schedule 'B'. Execution of items under this Schedule shall be carried out only after specific instructions of the Engineer. This Schedule consists of items for Civil works. The work has to be carried out as per Schedule of items given in this Schedule 'C'. This Schedule contains only Rate and Unit of items of the works. The basis of payment will be the actual quantities of work ordered and carried out, as measured by the Contractor and verified by the Engineer and valued at the rates and prices quoted in the Price Schedules. The Tenderer has to quote the percentage (%) Excess (+) or Less (-) over the *total Estimated Cost of Schedule 'C' (which is shown as "Estimated Rate" against Schedule 'C' in BOQ2 of MS excel file on e-procurement portal)* Schedule 'C' for items to be executed against this head.

1.5. The Schedules may not generally give a full description of the works to be performed and the plant or equipment to be supplied under each item. Tenderers shall be deemed to have read

the Employer's Requirements and the other sections of the Tender Documents and reviewed the Drawings to ascertain the full scope of the requirements included in each item prior to filling the rates and prices.

- 1.6. The price quoted in the Price Schedules for Schedule 'A'. Schedule 'B' and Schedule 'C' are for complete and finished items of the work in all respects. The Price quoted in the Price Schedules shall, except in so far as it is otherwise provided under the Contract, shall include all design, include all necessary survey work, plants, tools, machinery, Contractor's equipment, labour, compliance of labour laws, supervision, materials, transportation, handling, loading & unloading, storage, sampling, testing, fuel, oil, consumables, electric power, water, all leads & lifts, dewatering, all temporary works including temporary accesses, staging, form works and false works, stacking, provision and maintenance of all temporary works area, construction of temporary store and buildings, fencing, barricading, lighting, drainage arrangements, erection & maintenance of inspection facilities above and below ground such as brick, concrete and steel etc., reinstatement, remedy of any defects during the Defects Notification Period, safety measures for workmen and road users, preparation of design and drawings pertaining to permanent and temporary works, & *temporary diversion works, temporary road widening*, traffic diversion works, mobilisation and demobilisation, establishment and overhead charges, labour camps, insurance cost for labour and works, contractor's profit, all taxes including Goods and Service Tax (GST), insurance, royalties, duties, cess, octroi, other levies and other charges together with all general risks, liabilities and obligations set out or implied in the Contract.

The price and rates quoted by Tenderer shall be deemed to have included GST at the rate of 18% as notified by 47th GST Council on 29th June 2022 and Item 18.5 of Circular No. 177/09/2022-TRU dated 03rd August 2022 issued by Ministry of Finance, Government of India.

- 1.7. The whole cost of complying with the provisions of the Contract shall be included in the items provided in the Price Schedules, and where no items are provided, the cost shall be deemed to be distributed among the rates and prices entered for the related items of the Work.
- 1.8. To the extent acceptable to the Employer for the purpose of making payments or partial payments, valuing variations or evaluating claims, or for such other purposes as the Engineer may reasonably require, the Contractor may provide the Engineer with a breakdown of any composite or lump sum items included in the Schedules.
- 1.9. The Provisional Sums included and so designated in the Price Schedules shall be expended in whole or in part at the direction and discretion of the Engineer. The Provisional Sum shall be used to cover the Employer's share of the DAAB members' fees and expenses, in accordance with Clause 21. No prior instruction of the Engineer shall be required with respect to the work of the DAAB in accordance with Sub-Clause 13.4 of Part B-Specific Provisions - Particular Conditions of Contract. The Contractor shall submit the DAAB members' invoices and

satisfactory evidence of having paid 100% of such invoices as part of the substantiation of those statements submitted under Sub-Clause 14.3. in accordance with Sub-Clauses 13.4 of the General Conditions.

- 1.10. The prices shall be quoted against Schedule 'A', Schedule 'B' and Schedule 'C' in the Price Schedule (Excel Workbook) uploaded on the e-Procurement portal.
- 1.11. The prices quoted shall be comprehensive and must include for complying in all respects with the Price Schedules, Instruction to Tenderers, the General Conditions, the Particular Conditions, Employer's Requirements, Specifications and Drawings and for all matters and things necessary for the proper construction, completion, and making good of any defect in part or of the whole of the Works.
- 1.12. No claims for additional payment shall be allowed for any error or misunderstanding by the Contractor of the work involved.
- 1.13. *The rates quoted by the Tenderer are for design and construction of the Works as per approved Alignment Plan and Longitudinal Section and approved GADs of bridges as per the Scope of the Works.*

2 Variations in Price Schedule 'A', Schedule 'B' and Schedule 'C'

- 2.1 Variations in Price Schedules shall be dealt in accordance with Sub Clause 13.3.1 of Part B-Specific Provisions, Section IX- Particular Conditions of Contract.
- 2.2 The through Chainages mentioned in the Scope of the Works/Tender Drawings can undergo some minor corrections, without any impact on the overall length/Scope of the Works.

3 Measurement and Payment

- 3.1 The measurement shall be made as per Price Schedules i.e. Schedule 'A'. Schedule 'B' and Schedule 'C' and other relevant provisions of the Contract such as Employer's Requirements and the Drawings.
- 3.2 If during execution of the Contract, it is decided by the Employer/Engineer that one or more items of Work/Milestone of a Cost Centre in a particular Price Schedule is not required to be executed, the proportionate amount against that particular Item of Work/Milestones shall not be paid. The Engineer's decision in this regard shall be final.
- 3.3 The Payment shall be made as per Clause 14 [Contract Price and Payment] of the General Conditions and Particular Conditions.
- 3.4 The Employer shall make interim payments to the Contractor in accordance with the provisions of Sub-Clause 14.6 [Issue of Interim Payment Certificates] of the General Conditions and Particular Conditions, as certified by the Engineer on the basis of the progress achieved for the items of works/stages/Milestones of the works.

- 3.5** The Contractor shall base its claim for interim payment in accordance with Sub-Clause 14.3 [Application for Interim Payment] of the General Conditions and Particular Conditions for each stage for various items of work on the basis of actual progress of work executed (i.e. Milestones achieved) till the end of the month for which the payment is claimed in relation to the Contractor's total executed quantity, supported with documents and updated programme in accordance with the Employer's Requirements.
- 3.6** The Employer may carry out necessary tests, either directly or through an independent agency, of the Works done by the Contractor for which payment has been accepted and certified by the Engineer. The payment shall depend upon the outcome of such tests.
- 3.7** Format for the Contractor's application for payment shall be agreed between the Engineer and the Contractor.
- 3.8** All necessary supplementary details to support progress claims, including all certified Request for Inspection in hard bound copy, shall be included with application for payment. Sketches, drawings, approvals, calculations, test reports etc. shall accompany an application for payment to be substantiated and certified by the Engineer and submitted to the Employer.
- 3.9** Even if no work is executed during the month, or the Contractor does not choose to issue an application for payment, a 'NIL' application shall be submitted.
- 3.10** For the purposes of payment, the Contractor shall submit to the Engineer a detailed Price Schedule indicating a further breakdown for each stage of payment contained in the Price Schedules within forty-two (42) days after the receipt of the Letter of Acceptance. Such cost breakdowns shall be subject to approval of the Engineer who shall review and evaluate with comments and/or issue approval within twenty-eight (28) days of receipt of same. The Contractor shall resubmit the cost breakdown structure corresponding to the Engineer's comments for review, if required.
- 3.11** The Engineer is not obliged to issue an Interim Payment Certificate until such breakdown structure of payment schedule has been submitted and accepted by the Engineer.

4 Methodology for Claiming Payment

- 4.1** The Contractor shall prepare his monthly application for payment in the agreed format in two hard copies and one soft copy. This shall be accompanied by supplementary details in accordance with Sub-Clause 14.3 [Application for Interim Payment Certificates] of the General Conditions. All hard copies shall bear the original signatures of the Contractor's Representative and be submitted to the Engineer.
- 4.2** If these are found in order, in accordance with Sub-Clause 14.6 [Issue of Interim Payment Certificates] of the General Conditions, then the Engineer shall forward two certified copies of the application along with certified supplementary details to the Employer, with his recommendation for payment; otherwise, all documents shall be returned to the Contractor for

rectification and resubmission.

5 Schedules

5.1 Schedule “A’- Breakup of Lump Sum cost of Works under various Sub-Heads shall be as follows:

Sub-Head	Description	Percentage of the quoted lump sum cost of Schedule ‘A’	No. of Cost Centres	Total Cost of each Sub-Head
1	2	3	4	5
C	Civil & BLT works	96%	6	$C = 0.96 \times LS^*$
E	General Electrical Services works	4%	3	$E = 0.04 \times LS$

*LS = Total lump sum *accepted* cost of Works for Schedule ‘A’

5.2 Apportionment of Contract Price for payments under various Cost Centre for Sub-Head 'C'- Civil & BLT Works

Cost Centre	Description of Cost Centre	Percentage of Cost Centre 'C'	Total Cost of Cost Centre	Total Cost of Sub-Head 'C'
1	2	3	4	5
CG	General	2.00%	CG= 0.02x 'C'	96% of SCH 'A'
CE	Earthwork & blanketing	1.2%	CE=0.012x 'C'	
CB	Bridges	1.44%	CB=0.0144x 'C'	
CTU	Tunnel & Shafts	90.84%	CTU=0.9084x 'C'	
CBT	Ballastless Track	4.52%	CBT=0.0452x 'C'	
Total		100%		

Note: Value of 'C' shall be as defined in Sub-Clause 5.1 above.

The percentage figures as filled in column (3) by the Employer for the apportionment of the Contract Price for completion of the Works corresponding to the various Sub-Heads and Cost Centres are fixed and payment will be released for different Cost centre as per above percentage break-up of Contract Price.

5.3 Stages of Payment i.e. Milestones of Cost Centre 'CG'- General

Cost Centre			'CG'- General	
Weightage of Cost Centre 'CG', (Y)-			2%	
Sub Cost Centre	Item of Work		Milestone	Weightage (X)
	No.	Description		
1	2	3	4	5
CG1- General	CG.1	GT investigation	GT investigations and submission & approval of GIR.	20%
CG2- Design	CG.2.1		Submission and approval of preliminary and final design and Good for Construction (GFC) drawings of portals, tunnels, permanent ventilation shafts & construction cum utility shaft.	30%

Cost Centre			'CG'- General	
Weightage of Cost Centre 'CG', (Y)-			2%	
Sub Cost Centre	Item of Work		Milestone	Weightage (X)
	No.	Description		
1	2	3	4	5
	CG.2.2		Submission and approval of GAD, final design and Good for Construction (GFC) drawings of bridges and embankment	10%
	CG.2.3		Submission and approval of preliminary and final design and Good for Construction (GFC) drawings of Ballastless track	20%
CG.3- "As Built" Drawings & Documents	CG.3.1	As Built Drawings	Submission of "As Built" Drawings	10%
	CG.3.2	As Built Documents	Submission of "As Built" Documents	10%
			Total	100%

Note:

1. The value of each Milestone will be 96% of total lump sum *accepted* cost of Works for Schedule 'A' (LS) multiplied by X * Y. For example, *the value of Milestone* CG.1 will be = $0.96 \times LS \times X \times Y = 0.96 \times LS \times 0.20 \times 0.02$.
2. Adjustment to Contract Price pursuant to GCC 13.7 shall **NOT** be applicable to the payments of Works executed under this Cost Centre.
3. Payment will be made on Completion of each Milestones as per weightage given in this Cost Centre

5.4 Stages of Payment i.e. Milestones of Cost Centre 'CE'- Earthwork and Blanketing

Cost Centre			'CE'- Earthwork and Blanketing	
Weightage of Cost Centre 'CE', (Y)-			1.2%	
Sub-Cost Centre	Item of Work		Milestone	Weightage (X)
	No.	Description		
1	2	3	4	5
CE.1- Earthwork	CE.1.1	Earthwork in formation from Ch 12000 to 12500 for double main line track.		
	CE1.1.1		Earthwork in embankment / cutting including compaction.	3.4%
	CE1.1.2		On cutting of <i>extra width & dressing of slopes</i> in profile, compaction, <i>providing vegetative cover including coir netting (where specified) and drainage arrangement</i> complete in all respects.	0.2%
	CE1.1.3		On completion of maintenance of slopes, drainage system & vegetative cover for a period of 12 months and after ensuring that vegetative cover is properly rooted.	0.2%
	CE.1.2	Earthwork in formation from Ch 12500 to 13000 for double main line track.		
	CE1.2.1		Earthwork in embankment / cutting including compaction.	3.4%
	CE1.2.2		On cutting of <i>extra width & dressing of slopes</i> in profile, compaction, <i>providing vegetative cover including coir netting (where specified) and drainage arrangement</i> complete in all respects.	0.2%
	CE1.2.3		On completion of maintenance of slopes, drainage system &	0.2%

Cost Centre			'CE'- Earthwork and Blanketing	
Weightage of Cost Centre 'CE', (Y)-			1.2%	
Sub-Cost Centre	Item of Work		Milestone	Weightage (X)
	No.	Description		
1	2	3	4	5
			<i>vegetative cover for a period of 12 months and after ensuring that vegetative cover is properly rooted.</i>	
	CE.1.3	Earthwork in formation from Ch 13000 to 13500 for double main line track.		
	CE1.3.1		Earthwork in embankment / cutting including compaction.	3.4%
	CE1.3.2		On cutting of <i>extra width & dressing of slopes</i> in profile, compaction, <i>providing vegetative cover including coir netting (where specified) and drainage arrangement</i> complete in all respects.	0.2%
	CE1.3.3		On completion of maintenance of <i>slopes, drainage system & vegetative cover for a period of 12 months and after ensuring that vegetative cover is properly rooted.</i>	0.2%
	CE.1.4	Earthwork in formation from Ch 13500 to 14000 for double main line track.		
	CE.1.4.1		Earthwork in embankment / cutting including compaction.	3.9%
	CE.1.4.2		On cutting of <i>extra width & dressing of slopes</i> in profile, compaction, <i>providing vegetative cover including coir netting (where specified) and drainage arrangement</i> complete in all respects.	0.2%

Cost Centre			'CE'- Earthwork and Blanketing	
Weightage of Cost Centre 'CE', (Y)-			1.2%	
Sub-Cost Centre	Item of Work		Milestone	Weightage (X)
	No.	Description		
1	2	3	4	5
	CE.1.4.3		On completion of maintenance of slopes, drainage system & vegetative cover for a period of 12 months and after ensuring that vegetative cover is properly rooted.	0.2%
	CE.1.5	Earthwork in formation from Ch 14000 to 14500 for double main line track.		
	CE.1.5.1		Earthwork in embankment / cutting including compaction.	4.3%
	CE.1.5.2		On cutting of extra width & dressing of slopes in profile, compaction, providing vegetative cover including coir netting (where specified) and drainage arrangement complete in all respects.	0.2%
	CE.1.5.3		On completion of maintenance of slopes, drainage system & vegetative cover for a period of 12 months and after ensuring that vegetative cover is properly rooted.	0.2%
	CE.1.6	Earthwork in formation from Ch 14500 to 15000 for double main line track.		
	CE.1.6.1		Earthwork in embankment / cutting including compaction.	4.3%
	CE.1.6.2		On cutting of extra width & dressing of slopes in profile, compaction, providing vegetative cover including coir netting (where specified) and drainage arrangement	0.2%

Cost Centre			'CE'- Earthwork and Blanketing	
Weightage of Cost Centre 'CE', (Y)-			1.2%	
Sub-Cost Centre	Item of Work		Milestone	Weightage (X)
	No.	Description		
1	2	3	4	5
			complete in all respects.	
	CE.1.6.3		On completion of maintenance of slopes, drainage system & vegetative cover for a period of 12 months and after ensuring that vegetative cover is properly rooted.	0.2%
	CE.1.7	Earthwork in formation from Ch 15000 to 15500 for double main line track.		
	CE.1.7.1		Earthwork in embankment / cutting including compaction.	4.3%
	CE.1.7.2		On cutting of extra width & dressing of slopes in profile, compaction, providing vegetative cover including coir netting (where specified) and drainage arrangement complete in all respects.	0.3%
	CE.1.7.3		On completion of maintenance of slopes, drainage system & vegetative cover for a period of 12 months and after ensuring that vegetative cover is properly rooted.	0.2%
	CE.1.8	Earthwork in formation from Ch 15500 to 16000 for double main line track.		
	CE.1.8.1		Earthwork in embankment / cutting including compaction.	4.3%
	CE.1.8.2		On cutting of extra width & dressing of slopes in profile, compaction, providing vegetative cover including coir	0.3%

Cost Centre			'CE'- Earthwork and Blanketing	
Weightage of Cost Centre 'CE', (Y)-			1.2%	
Sub-Cost Centre	Item of Work		Milestone	Weightage (X)
	No.	Description		
1	2	3	4	5
			<i>netting (where specified) and drainage arrangement complete in all respects.</i>	
	CE.1.8.3		<i>On completion of maintenance of slopes, drainage system & vegetative cover for a period of 12 months and after ensuring that vegetative cover is properly rooted.</i>	0.2%
	CE.1.9	Earthwork in formation from Ch 16000 to 16500 for double main line track.		
	CE.1.9.1		Earthwork in embankment / cutting including compaction.	4.3%
	CE.1.9.2		<i>On cutting of extra width & dressing of slopes in profile, compaction, providing vegetative cover including coir netting (where specified) and drainage arrangement complete in all respects.</i>	0.3%
	CE.1.9.3		<i>On completion of maintenance of slopes, drainage system & vegetative cover for a period of 12 months and after ensuring that vegetative cover is properly rooted.</i>	0.2%
	CE.1.10	Earthwork in formation from Ch 16500 to 17000 for double main line track.		
	CE.1.10.1		Earthwork in embankment / cutting including compaction.	4.3%
	CE.1.10.2		<i>On cutting of extra width & dressing of slopes in profile, compaction, providing</i>	0.3%

Cost Centre			'CE'- Earthwork and Blanketing	
Weightage of Cost Centre 'CE', (Y)-			1.2%	
Sub-Cost Centre	Item of Work		Milestone	Weightage (X)
	No.	Description		
1	2	3	4	5
			<i>vegetative cover including coir netting (where specified) and drainage arrangement complete in all respects.</i>	
	CE.1.10.3		On completion of maintenance of slopes, drainage system & vegetative cover for a period of 12 months and after ensuring that vegetative cover is properly rooted.	0.2%
	CE.1.11	Earthwork in formation from Ch 17000 to 17500 for double main line track.		
	CE.1.11.1		Earthwork in embankment / cutting including compaction.	5.0%
	CE.1.11.2		On cutting of <i>extra width & dressing of slopes</i> in profile, compaction, <i>providing vegetative cover including coir netting (where specified) and drainage arrangement complete in all respects.</i>	0.4%
	CE.1.11.3		On completion of maintenance of slopes, drainage system & vegetative cover for a period of 12 months and after ensuring that vegetative cover is properly rooted.	0.2%
	CE.1.12	Earthwork in formation from Ch 17500 to 18000 for double main line track.		
	CE.1.12.1		Earthwork in embankment / cutting including compaction.	5.0%
	CE.1.12.2		On cutting of <i>extra width & dressing of slopes</i> in profile,	0.4%

Cost Centre			'CE'- Earthwork and Blanketing	
Weightage of Cost Centre 'CE', (Y)-			1.2%	
Sub-Cost Centre	Item of Work		Milestone	Weightage (X)
	No.	Description		
1	2	3	4	5
			compaction, <i>providing vegetative cover including coir netting (where specified) and drainage arrangement complete in all respects.</i>	
	CE.1.12.3		On completion of maintenance of slopes, drainage system & vegetative cover for a period of 12 months and after ensuring that vegetative cover is properly rooted.	0.2%
	CE.1.13	Earthwork in formation from Ch. 29580 to 29680	On completion of earthwork in cutting including <i>providing vegetative cover including coir netting (where specified) and drainage arrangement complete in all respect.</i>	4.9%
CE.2-Blanketing	CE.2.1	Blanketing from Ch 12000 to 12500 for double main line track.	Blanketing on subgrade/ prepared subgrade as per design profile including compaction complete in all respects.	3.3%
	CE.2.2	Blanketing from Ch 12500 to 13000 for double main line track.	Blanketing on subgrade/ prepared subgrade as per design profile including compaction complete in all respects.	3.3%
	CE.2.3	Blanketing from Ch 13000 to 13500 for double main line track.	Blanketing on subgrade/ prepared subgrade as per design profile including compaction complete in all respects.	3.3%
	CE.2.4	Blanketing from Ch 13500 to 14000 for double main line track.	Blanketing on subgrade/ prepared subgrade as per design profile including compaction complete in all respects.	3.3%
	CE.2.5	Blanketing from Ch 14000 to	Blanketing on subgrade/ prepared subgrade as per	3.3%

Cost Centre			'CE'- Earthwork and Blanketing	
Weightage of Cost Centre 'CE', (Y)-			1.2%	
Sub-Cost Centre	Item of Work		Milestone	Weightage (X)
	No.	Description		
1	2	3	4	5
		14500 for double main line track.	design profile including compaction complete in all respects.	
	CE.2.6	Blanketing from Ch 14500 to 15000 for double main line track.	Blanketing on subgrade/ prepared subgrade as per design profile including compaction complete in all respects.	3.3%
	CE.2.7	Blanketing from Ch 15000 to 15500 for double main line track.	Blanketing on subgrade/ prepared subgrade as per design profile including compaction complete in all respects.	3.3%
	CE.2.8	Blanketing from Ch 15500 to 16000 for double main line track.	Blanketing on subgrade/ prepared subgrade as per design profile including compaction complete in all respects.	3.3%
	CE.2.9	Blanketing from Ch 16000 to 16500 for double main line track.	Blanketing on subgrade/ prepared subgrade as per design profile including compaction complete in all respects.	3.3%
	CE.2.10	Blanketing from Ch 16500 to 17000 for double main line track.	Blanketing on subgrade/ prepared subgrade as per design profile including compaction complete in all respects.	3.3%
	CE.2.11	Blanketing in formation from Ch 17000 to 17500 for double main line track.	Blanketing on subgrade/ prepared subgrade as per design profile including compaction complete in all respects.	3.3%

Cost Centre			'CE'- Earthwork and Blanketing	
Weightage of Cost Centre 'CE', (Y)-			1.2%	
Sub-Cost Centre	Item of Work		Milestone	Weightage (X)
	No.	Description		
1	2	3	4	5
	CE.2.12	Blanketing from Ch 17500 to 18000 for double main line track.	Blanketing on subgrade/ prepared subgrade as per design profile including compaction complete in all respects.	3.3%
Total				100%

Note:

1. The value of each Milestone will be 96% of total lump sum *accepted* cost of Works for Schedule 'A' (LS) multiplied by X * Y. For example, *the value of Milestone CE.1.1.1 will be = 0.96xLSxXxY=0.96x LSx0.034 x 0.012.*
2. Adjustment to Contract Price pursuant to GCC 13.7 shall be applicable to the payments of Works executed under this Cost Centre / Price Schedule.
3. Payment will be made on Completion of each Milestones as per weightage given in this schedule.

5.5 Stages of Payment i.e. Milestones of Cost Centre 'CB'- for Bridges

Cost Centre			'CB'- Bridges	
Weightage of Cost Centre 'CB', (Y)-			1.44%	
Sub-Cost Centre	Item of Work		Milestone	Weightage (X)
	No.	Description		
1	2	3	4	5
CB.1- Minor Bridges	CB1.1	Construction of minor bridge No. 47, 48 & 49 between ch 12000 to 12500 for main line track.	On completion of <i>bridgeworks in all respects</i>	22.4%
	CB1.2	Construction of minor bridge No. 50 between ch 12500 to 13000 for main line track.	On completion of <i>bridgeworks in all respects</i>	5.6 %
	CB1.3	Construction of minor bridge No. 51 between ch 13000 to 13500 for main line track.	On completion of <i>bridgeworks in all respects</i>	6.3 %
	CB1.4	Construction of minor bridge No. 52 between ch 13500 to 14000 for main line track.	On completion of <i>bridgeworks in all respects</i>	4.4 %
	CB1.5	Construction of minor bridge No. Nil between ch 14000 to 14500 for main line track.	-	0%
	CB1.6	Construction of minor bridge No. 54 & 55 between ch 14500 to 15000 for main line track.	On completion of <i>bridgeworks in all respects</i>	21.7%
	CB1.7	Construction of minor bridge No. 56 between ch 15000 to 15500 for main line track.	On completion of <i>bridgeworks in all respects</i>	5.8%
	CB1.8	Construction of minor bridge No. 57 between ch 15500 to 16000 for main line track.	On completion of <i>bridgeworks in all respects</i>	14.8%
	CB1.9	Construction of minor bridge No. Nil between ch 16000 to 16500 for main line track.	-	0%

Cost Centre			'CB'- Bridges	
Weightage of Cost Centre 'CB', (Y)-			1.44%	
Sub-Cost Centre	Item of Work		Milestone	Weightage (X)
	No.	Description		
1	2	3	4	5
	CB1.10	Construction of minor bridge No. Nil between ch 16500 to17000 for main line track.	-	0%
	CB1.11	Construction of minor bridge No. Nil between ch 17000 to17500 for main line track.	-	0%
	CB1.12	Construction of minor bridge No. Nil between ch 17500 to18000 for main line track.	-	0%
CB.2-Major Bridges	CB.2.1	Foundation	On completion of the foundation work including pile caps/ well caps and foundations for wing and return walls and testing.	4.0%
	CB.2.2	Substructure	On Completion of Abutment/Piers including Abutment/Pier Cap without bearings.	
	CB.2.2.1		Pier/Abutment	3%
	CB.2.2.2		Pier/Abutment cap	0.5%
	CB.2.2.3		Completion of the wing walls, return walls in all respects	2.5%
	CB.2.3	Superstructure	On completion of superstructure <i>including launching in position.</i>	5.0%
	CB.2.4		On completion of balance works as per drawing like-protection works including Toe wall, Pitching, inspection platform at each pier & abutment <i>including</i> access ladder, inspection steps, Bridge plaque,	4%

Cost Centre			'CB'- Bridges	
Weightage of Cost Centre 'CB', (Y)-			1.44%	
Sub-Cost Centre	Item of Work		Milestone	Weightage (X)
	No.	Description		
1	2	3	4	5
			Bridge board, painting of HFL, Height gauge & drainage arrangements in RUBs and testing on completion, if any, complete in all respect and fit for use.	
Total				100%

Note:

1. The value of each Milestone will be 96% of total lump sum *accepted* cost of Works for Schedule 'A' (LS) multiplied by X * Y. For example, *the value of Milestone CB1.1* will be = $0.96 \times LS \times X \times Y = 0.96 \times LS \times 0.224 \times 0.0144$.
2. Adjustment to Contract Price pursuant to GCC 13.7 shall be applicable to the payments of Works executed under this Cost Centre / Price Schedule.
3. Payment will be made on Completion of each Milestones as per weightage given in this schedule.
4. CB2-Major Bridges:
 - (i) For the purpose of stage payment/Milestones, cost of a bridge shall be taken in proportion to its linear length measured along the alignment to the total linear length of all major bridges.
 - (ii) Payment of each stage/Milestones for a bridge will be made on completion of the relevant stage as per the weightage given in this schedule in proportion to the cost of the bridge.
5. Stages CB.2.1 to CB.2.2 will further be subdivided into the number of piers + 2 abutments, as applicable as per approved drawing by the Engineer, and Milestones for completed work for each pier and abutment shall be made as per the requirement of the stages stated above.
6. For PSC slabs payment against sub cost centre 2.3 shall be released as per following schedule-
 - (i) On casting of PSC slabs: 50%
 - (ii) On prestressing: 20%
 - (iii) On completion in all respect: 30%

7. *The cost of Milestones included cost of all temporary work and temporary diversion of road wherever required for all bridges included in Schedule 'A', Section VII-2, Employer's Requirements.*

5.6 Stages of Payment i.e. Milestones of Cost Centre 'CTU'- Tunnel & Shafts

Cost Centre			'CTU'- Tunnel	
Weightage of Cost Centre 'CTU', (Y)-			90.84	
Sub-cost Centre	Item of Work		Milestone	Weightage (X)
	No.	Description		
1	2	3	4	5
CTU.1- Permanent ventilation Shafts and Construction cum utility shaft	CTU1.1	Completion of excavation for construction of permanent ventilation shafts and Construction cum utility shaft		
	CTU1.1.1		Construction of Permanent Ventilation Shaft No. 1 at Chainage 26080	0.8%
	CTU1.1.2		Construction of Permanent Ventilation Shaft No. 2 at Chainage 26080	0.8%
	CTU1.1.3		Construction of Permanent Ventilation Shaft No. 3 at Chainage 27680	0.8%
	CTU1.1.4		Construction of Permanent Ventilation Shaft No. 4 at Chainage 27680	0.8%
	CTU1.1.5		Construction of Construction cum Utility Shaft at Chainage 26950	0.8%
CTU.2- NATM Drive	CTU2.1	On completion of first round of the Excavation by NATM from		
	CTU2.1.1		Face F1	0.5%
	CTU2.1.2		Face F2	0.5%
	CTU2.1.3		Face F3	0.5%
	CTU2.1.4		Face F4	0.5%
	CTU2.1.5		Face F5	0.5%

Cost Centre			'CTU'- Tunnel	
Weightage of Cost Centre 'CTU', (Y)-			90.84	
Sub-cost Centre	Item of Work		Milestone	Weightage (X)
	No.	Description		
1	2	3	4	5
	CTU2.1.6		Face F6	0.5%
	CTU2.1.7		Face F7	0.5%
	CTU2.1.8		Face F8	0.5%
	CTU2.1.9		Face F9	0.5%
	CTU2.1.10		Face F10	0.5%
	CTU2.1.11		Face F11	0.5%
	CTU2.1.12		Face F12	0.5%
	CTU2.1.13		Face F13	0.5%
	CTU2.1.14		Face F14	0.5%
CTU.3	CTU.3.1		NATM Main Drive of both tunnels from chainage 24850 (<i>Up line</i>) & 24853 (<i>Dn line</i>) to 26067.5m	On Completion of NATM Main Drive (On account payment will be made on proportionate basis based on actual work progress in m divided by Total length of NATM drive)
	CTU.3.2	NATM Main Drive of both tunnels from chainage 26092.5m to 27667.5m and from chainage 27692.5m to 28480m	On Completion of NATM Main Drive (On account payment will be made on proportionate basis based on actual work progress in m including Benching divided by Total length of NATM drive)	37.4%
CTU.4- Secondary Lining	CTU4.1	Secondary lining in both tunnels in NATM portion	On completion of Secondary Lining (on account payment will be made on proportionate basis based on actual progress of work in meter divided by total length of NATM tunnel)	14%
CTU.5- Cut & Cover Tunnel	CTU 5.1	Excavation of Cut & Cover Tunnel	Excavation for Cut & Cover tunnel (On account payment will be made on proportionate basis based on actual progress of work	4.6%

Cost Centre			'CTU'- Tunnel	
Weightage of Cost Centre 'CTU', (Y)-			90.84	
Sub-cost Centre	Item of Work		Milestone	Weightage (X)
	No.	Description		
1	2	3	4	5
			in sqm on Plan divided by Total area in sqm on Plan)	
	CTU 5.2	Cut & Cover Tunnel Structures	Completion of Cut & Cover Tunnel Structures including waterproofing, backfill & drainage arrangement (on account payment will be made on proportionate basis based on actual work progress in sqm on Plan divided by Total area in sqm on Plan)	10%
CTU5- Cross Passage	CTU5.1	Cross Passage	Construction of Cross Passages	3.0%
CTU6- Miscellaneous works	CTU6.1	Miscellaneous	Construction of Portal P2, Footpath, Drainage, Restoration of the Areas etc. complete in all respect.	9.0%
Total				100%

Note:

1. The value of each Milestone will be 96% of total lump sum *accepted* cost of Works for Schedule 'A' (LS) multiplied by X * Y. For example, *the value of Milestone* CTU1.1.1 will be = $0.96 \times LS \times X \times Y = 0.96 \times LS \times 0.008 \times 0.9084$.
2. Adjustment to Contract Price pursuant to GCC 13.7 shall be applicable to the payments of Works executed under this Cost Centre / Price Schedule.
3. *Inc case of any addition / reduction in the length of tunnel due to change in the location of Portal P-1, payment/deduction shall be made @ INR 9.60 lacs per metre addition/reduction in the length of tunnel.*

5.7 Stages of Payment i.e. Milestones of Cost Centre ‘CBT’- Ballastless Track

Cost Centre			‘CBT’- Ballastless Track	
Weightage of Cost Centre ‘CBT’, (Y)-			4.52%	
Sub-Cost Centre	Item of Work		Milestone	Weightage (X)
	No.	Description		
1	2	3	4	5
CBT.1	CBT1.1	Supply of Fastening system	On supply of Track fitting/fastening system complete	15%
	CBT1.2	Construction of ballastless track	Construction of ballastless track (On account payment will be made on proportionate basis based on actual work progress in meter divided by total length of ballastless track)	65%
	CBT1.3	Misc. works	On completion of all balance works as per drawings like welding into LWR, destressing, drainage, supply of spare fittings/ fastenings for BLT etc. complete.	10%
	CBT1.3	Maintenance	Maintenance of ballastless track for one year after start of traffic (to be paid monthly on pro rata basis based on satisfactory performance certificate by the Engineer.)	10%
			Total	100%

Note:

1. The value of each Milestone will be 96% of total lump sum *accepted* cost of Works for Schedule ‘A’ (LS) multiplied by X * Y. For example, *the value of Milestone CBT1.1* will be = $0.96 \times LS \times X \times Y = 0.96 \times LS \times 0.15 \times 0.0452$.
2. Adjustment to Contract Price pursuant to GCC 13.7 shall be applicable to the payments of Works executed under this Cost Centre / Price Schedule.

6 Apportionment of the Contract Price for Schedule ‘A’ under various Cost Centre for Sub-Head ‘E’-General Electrical Services works

Cost Centre	Description of Cost Centre	Percentage of Cost Centre	Total Cost of Cost Centre	Total Cost of Sub-Head “E”
1	2	3	4	
E1	General Electrical Services works	94.36%	$E1=0.9436 \times 'E'$	4% of Schedule ‘A’
E2	<i>Contract Spares, Tools & Tackles and Measuring Instruments</i>	4.83%	$E2=0.0483 \times 'E'$	
E3	Maintenance and Manning of electrical system for one year	0.81%	$E3=0.0081 \times 'E'$	
Total		100%		

6.1 Stages of Payment i.e. Milestones of cost center E1. – General Electrical Services works

Cost center		E1. – General Electrical Services works		
Weightage of Cost Centre 'E1', (Y)		94.36 %		
Sub Cost Centre	Item of Work		Milestone	Weightage (X)
	No	Description		
1	2	3	4	5
E1.1	E1.1.1	Drawing and Design	Preparation and Submission of Drawing and Design for General Electrical Services works, Plan, Specifications, Load calculations, Reports and Drawing of civil structure/building for sub-stations etc. required for commissioning of Electrical System.	5.00%
E1.2	E1.2.1	Supply of Electrical Equipment and associated materials	Supply of equipment and associated material for the Electrical system and material for construction of civil structure/building for sub-stations. i. Major Electrical item like – 11 kVA GIC Panel, Transformers, DG sets, All types of cables, Cable Tray, LT Panels, all types of LED fittings and its associated items.	60.00%
E1.3	E1.3.1	Installation & Erection of Electrical Equipment	Delivery to Site from , Installation and Site Testing of all equipments for Electrical system (includes pre-installation tests and post installation tests). i. Construction of building for sub-stations. ii. Installation of all Electrical equipment iii. Installation of all required sensors and Earthing system.	20.00%
E1.4	E1.4.1	Testing and Commissioning	System Acceptance Tests (SAT) and Integrated Commissioning and Charging of Total Electrical system	15.00%
Total				100%

Note:

- 1** The value of each Milestone will be 4% of total Lump sum *accepted* cost of Works for Schedule 'A' (*LS*) multiplied by X * Y. For example, *the value of Milestone E1.1.1* will be = $0.04 \times LS \times X \times Y = 0.04 \times LS \times 0.05 \times 0.9436$.
- 2** Adjustment to Contract Price Shall Not be applicable E1.1 to the payments of Works executed under Cost Centre 'E1'.
- 3** Payment will be made on completion of each Milestones as per weightage given in this Cost Centre.
- 4** Payment against the Sub Cost Centre E1.2 shall be made for quantities as per the approved Design, on receipt of Material at contractor's depot, production of inspection certificates & other documents and against BG of equivalent amount.
- 5** Payment against each Sub Cost Centre shall be made only on completion of work under Sub Cost Centre.

6.2 Stages of Payment i.e. Milestones of cost center E2 – Contract Spares, Tools & Tackles and Measuring Instruments

Cost center			E2 – Contract Spares, Tools & Tackles and Measuring Instruments	
Weightage of Cost Centre 'E2', (Y)			4.83%	
Sub Cost Centre	Item of Work		Milestone	Weightage (X)
	No	Description		
1	2	3	4	5
E2.1	E2.1.1	<i>Contract Spares, Tools & Tackles and Measuring Instruments etc..</i>	<i>Supply of Contract Spares, Tools & Tackles and Measuring Instruments etc.</i>	100%
			Total	100%

Note:

1. The value of each Milestone will be 4% of total Lump sum *accepted* cost of Works for Schedule 'A' (LS) multiplied by X * Y. For example, *the value of Milestone E2.1.1 will be = 0.04xLSxXxY = 0.04 x 1x 0.0483.*
2. Adjustment to Contract Price shall be applicable to the payments of Works executed under Cost Centre 'E2'.
3. Payment will be made on completion of each Milestones as per weightage given in this Cost Centre.

6.3 Stages of Payment i.e., Milestones of Cost Centre E3 – Maintenance and Manning of Electrical system *for one year*

Cost center			E3 – Maintenance and Manning of Electrical system <i>for one year</i>	
Weightage of Cost Centre ‘E3’, (Y)			0.81%	
Sub Cost Centre	Item of Work		Milestone	Weightage (X)
	No	Description		
1	2	3	4	5
E3.1	E3.1.1	Maintenance and Manning of <i>Electrical system</i> for one year	Maintenance and Manning of Electrical system <i>for one year</i>	100.00%

Note:

1. The value of each Milestone will be 4% of total Lump sum *accepted* cost of Works for Schedule ‘A’ (LS) multiplied by X * Y. For example, *the value of Milestone E3.1 will be = 0.04xLSxXxY = 0.04 xLSx 1x 0.0081.*
2. Adjustment to Contract Price shall be applicable to the payments of Works executed under Cost Centre ‘E3’.
3. Payment will be made on completion of each Milestones as per weightage given in this Cost Centre.

7 Schedule 'B': Other civil works

Schedule 'B'/R1 Other Civil Works							
S. No	Item No.	Description of Item	Quantity	Unit	NWR USSOR/DS R Rate in INR	Estimated rate including GST @ 18 % in INR	Estimated Amount in INR
Schedule B1:- NWR-USSOR 2019 BASED ITEMS							
1	011010	Earthwork in cutting (classified) in formation, trolley refuges, side drains, level crossing approaches, platforms, catch water drains, diversion of nallah & finishing to required dimension and slopes to obtain a neat appearance to standard profile inclusive of all labour, machine & materials and removing & leading all cut spoils either to make spoil dumps beyond 10m from cutting edge or for filling in embankment with leads within 2 km on either side of cutting edge, lifts, ascent, descent, loading, unloading, all taxes / royalty, clearance of site and all incidental charges, bailing & pumping out water, if required, etc. complete as per directions of the Engineer in-Charge. The work is to be executed as per latest / updated edition of "Guidelines for Earthwork in Railway Projects" issued by RDSO, Lucknow. Cut trees shall be property of Railways and to be deposited in the railway godown unless specified otherwise in the Special Conditions of Contract. {Note - (i) All usable earth arising from cut spoils shall be led into bank formation and Unusable spoils shall be dumped /					

Schedule 'B'/R1 Other Civil Works							
S. No	Item No.	Description of Item	Quantity	Unit	NWR USSOR/DS R Rate in INR	Estimated rate including GST @ 18 % in INR	Estimated Amount in INR
		stacked (ii) All hard rock /and boulders not fit for filling will be stacked by the contractor and will be property of the HRIDC.}					
1a	011012	Soft rock not requiring blasting in all conditions	2000	Cum	347.68	389.85	779,700.00
1b	011013	In hard rock requiring blasting with explosives and blasting/drilling equipment Including all incidental work in all conditions. Rate includes cost of all explosive material.	45000	Cum	545.17	611.28	27,507,600.00
1c	011014	In rock and very hard rock with hammer / chisel / pavement breaker etc. where blasting is not permitted due to special circumstances and if specifically ordered in writing including drilling and all incidental work in all conditions	5000	Cum	1,225.22	1,373.80	6,869,000.00

Schedule 'B'/R1 Other Civil Works							
S. No	Item No.	Description of Item	Quantity	Unit	NWR USSOR/DS R Rate in INR	Estimated rate including GST @ 18 % in INR	Estimated Amount in INR
2	022010	Earthwork in excavation by mechanical means (Hydraulic Excavator)/Manual Means for foundations and floors of the bridges, retaining walls etc. including setting out, dressing of sides, ramming of bottom, getting out the excavated material, back filling in layers with approved material and consolidation of the layers by ramming and watering etc. including all lift, disposal of surplus soil upto a lead of 300m, all types of shoring and strutting with all labour and material complete as per drawing and technical specification as directed by Engineer. Note: This item will be used for excavation work in connection with other miscellaneous works also like side drains, foundation for OHE masts and other miscellaneous structures in connection with Gauge Conversion, Doubling, New lines.					
2a	022011	All kinds of soils	6000	Cum	195.57	219.29	1,315,740.00

Schedule 'B'/R1 Other Civil Works							
S. No	Item No.	Description of Item	Quantity	Unit	NWR USSOR/DS R Rate in INR	Estimated rate including GST @ 18 % in INR	Estimated Amount in INR
3	022040	Providing and laying in position machine batched, machine mixed and machine vibrated Design Mix Cement Concrete of specified grade (M-20 Cast in-Situ) using 20mm graded crushed stone aggregate and coarse sand of approved quality in RCC raft foundation & Pile cap including finishing, using Admixtures in approved proportions (as per IS:9103), to modify workability & other properties without impairing strength and durability complete as per specifications and direction of the Engineer in charge. Payment for cement, reinforcement and shuttering shall be paid extra. Note -Cement concrete in drainage and other miscellaneous works shall be paid under this item.	1,737	Cum	2,840.33	3,184.77	5,531,945.49
4	022070	Providing and fixing Weep Holes in Abutments, RCC Box, Wing walls and Return walls etc., of new bridges with 110mm dia UPVC pipe (IS :13592) Type A ISI marked with all contractor's men, material, transportation, all taxes as per specifications and as directed by Engineer-in-Charge.	1,500	Rmt	242.28	282.93	424,395.00

Schedule 'B'/R1 Other Civil Works							
S. No	Item No.	Description of Item	Quantity	Unit	NWR USSOR/DS R Rate in INR	Estimated rate including GST @ 18 % in INR	Estimated Amount in INR
5	023010	Earth work in OPEN excavation in foundation of bridges, for placing of well curbs of all shapes and designs in all kinds of soil including taking out the excavated soil, levelling, ramming of bottom of excavation and trimming of sides, returning the soil in layers, consolidation, disposal of surplus soil within a lead of 300m, including all lift, dewatering, shoring and strutting complete as per technical specification and as directed by Engineer in charge. (compaction of surplus soil when led to the bank will be paid as per relevant item separately)	300	Cum	293.36	328.94	98,682.00
6	023030	Supplying, Fabrication, assembly, erection & placing in position the cutting edge of well curb with structural steel including MS sheet/Plates of specified thickness for pier/abutment complete as per approved plans and as per direction of Engineering In charge including all operations like cutting, bending, straightening, drilling holes, bolting, riveting, welding, threading, jointing of steel sections including outer and inner places liners and skin plates, stiffeners, hooks, bottle nuts, bond rods etc. as per design including all ascent, descents, leads, lifts, handing, re-handling, all other obstructions whatsoever, diverting channels, pumping / bailing out	9	MT	96,774.58	108,510.24	976,592.16

Schedule 'B'/R1 Other Civil Works							
S. No	Item No.	Description of Item	Quantity	Unit	NWR USSOR/DS R Rate in INR	Estimated rate including GST @ 18 % in INR	Estimated Amount in INR
		of water wherever required including cost of steel such as flats, sheets, angles, steel bars etc. with all labour and material as a complete job					
7	023040	Dry/Wet Sinking of Circular Wells (Other than pneumatic method) in all types of strata except hard rock requiring ballasting, including bailing and pumping out water, removal of excavated soil with all labour and material required for sinking as per drawing and direction of the Engineer in charge, disposal of surplus soil in the adjoining bank/embankment (compaction to be paid separately under the relevant item).					
7a	023041	From initial level of cutting edge & upto 3m depth	777	Cum	183.34	205.57	159,769.00
7b	023042	Above 3m to 10m depth	1,813	Cum	294.64	330.37	599,092.96
7c	023043	Above 10m to 15m depth	1,295	Cum	410.28	460.03	595,876.86
7d	023044	Above 15m to 20m depth	1,295	Cum	563.53	631.87	818,461.21
7e	023045	Above 20m to 25m depth	1,295	Cum	809.02	907.13	1,175,005.49

Schedule 'B'/R1 Other Civil Works							
S. No	Item No.	Description of Item	Quantity	Unit	NWR USSOR/DS R Rate in INR	Estimated rate including GST @ 18 % in INR	Estimated Amount in INR
7f	023045	Above 25m to 30m depth	648	Cum	1,249.18	1,400.67	907,213.96
8	023090	Providing and laying in position machine batched, machine mixed and machine vibrated Design Mix Cement Concrete of specified grade (Cast in-Situ) using 20mm graded crushed stone aggregate and coarse sand of approved quality in the following elements of well including finishing, using Admixtures in approved proportions (as per IS:9103), to modify workability & other properties without impairing strength and durability complete as per drawings and technical specifications as directed by Engineer. Payment for cement, reinforcement and shuttering shall be made extra.					
8a	023091	In well Curb	249	Cum	3,124.37	3,503.26	871,260.76
8b	023092	In Steining of wells	3,338	Cum	3,124.37	3,503.26	11,694,932.86
8c	023093	In Bottom plug for wells including arrangements for placing concrete under water with tremie or bottom opening skips.	432	Cum	3,124.37	3,503.26	1,512,707.67
8d	023095	In Intermediate/Top plug with internal shuttering	259	Cum	2,982.35	3,344.01	866,432.99

Schedule 'B'/R1 Other Civil Works							
S. No	Item No.	Description of Item	Quantity	Unit	NWR USSOR/DS R Rate in INR	Estimated rate including GST @ 18 % in INR	Estimated Amount in INR
8e	023096	In Well cap and corbel, if provided	412	Cum	2,982.35	3,344.01	1,378,735.32
9	023100	Supplying and filling ordinary sand in between bottom plug and top plug in wells including all lead lift handling, re-handling, as a complete job. Sand should be simultaneously filled with water for three days to achieve full compaction so that further chances of shrinkage due to voids are eliminated					
9a	023102	Using sand from other than River bed (This item is to be operated if suitable sand is not available in River Bed for filling	3,173	Cum	2,031.30	2,277.63	7,227,831.04
10	025020	Providing and applying two coats of coal tar or bitumen conforming to IS:3117– latest version on the top and sides of RCC box/slabs @ 1.70 kg/sqm after cleaning the surface with all labour and materials complete job as directed by the Engineer	3,150	Sqm	155.67	174.55	549,832.50
11	025030	centering and shuttering including strutting, propping etc. and removal of form for :					
11a	025031	All types of bridge sub-structures, e.g. pier, abutment, wing wall, retaining wall, RCC box type foundations, Abutment cap, Pier Cap, Inspection Platform & Pedestal over Pier cap, Fender wall, Diaphragm wall etc. upto 5m above ground level	16,500	Sqm	671.94	753.42	12,431,430.00

Schedule 'B'/R1 Other Civil Works							
S. No	Item No.	Description of Item	Quantity	Unit	NWR USSOR/DS R Rate in INR	Estimated rate including GST @ 18 % in INR	Estimated Amount in INR
11b	025032	All types of bridge super-structures, e.g. slabs, I-girders, T-girders, Box girders etc. upto 5m above ground level	3,200	Sqm	874.49	980.54	3,137,728.00
11c	025033	Extra for additional height over item no. 025031 & 025032 wherever required with adequate bracing, propping etc. over initial height of 5 metres for every additional height of 1 metre or part thereof	2,600	Sqm	110.17	123.53	321,178.00
12	025060	Supply and using Cement at Worksite					
12a	025062	Ordinary Portland Cement 53 grade	335	MT	7,398.80	8,623.08	2,888,731.80
12b	025063	Pozzolana Portland Cement	2060	MT	6,905.10	8,047.69	16,578,241.40
13	025070	Steel reinforcement for R.C.C. work including straightening, cutting, bending, placing in position and binding all complete					
13a	025072	Thermo-Mechanically Treated bars of grade Fe-500D or more.	1,576,620	Kg	78.01	87.70	138,269,574.00

Schedule 'B'/R1 Other Civil Works							
S. No	Item No.	Description of Item	Quantity	Unit	NWR USSOR/DS R Rate in INR	Estimated rate including GST @ 18 % in INR	Estimated Amount in INR
14	031020	Providing and laying in position machine batched, machine mixed and machine vibrated Design Mix Cement Concrete of specified grade using 20mm graded crushed stone aggregate and coarse sand of approved quality for the Precast Prestressed (Post tensioned) concrete girder/Box (spans upto 30.5m) in contractor's casting yard, including finishing, using Admixtures in approved proportions (as per IS:9103), to modify workability & other properties without impairing strength and durability, complete as per drawings, specifications and direction of the Engineer. Payment for Shuttering, Cement, reinforcement, HTS cables, anchorage cones, stressing of cables and grouting of the ducts will be done extra. Launching of girder/slab in position is not included in this item.	290	Cum	2,840.33	3,184.77	923,583.30
14a	031021	Deduct from 0310220 for casting of Slab in place of Girder/Box	290	Cum	42.48	47.63	-13,812.70

Schedule 'B'/R1 Other Civil Works							
S. No	Item No.	Description of Item	Quantity	Unit	NWR USSOR/DS R Rate in INR	Estimated rate including GST @ 18 % in INR	Estimated Amount in INR
15	031040	Providing, fabricating & fixing in position to exact design profiles, prestressing H.T.S. cables of all classification made from Low Relaxation strands conforming to IS:14268– latest version in Prestressed (Post tensioned) Concrete girders/slabs etc. including supplying, cutting, making into cables with necessary spacers, colour coding, protecting with water soluble oil at all time, anchoring of cables, supplying and placing spiral corrugated type galvanized metal steel ducts sheathing made up of Cold Rolled Cold Annealed (CRCA) mild steel conforming to IS:513 of required diameter/ thickness, vent pipe, placing, bending, routing, fixing, stressing & grouting of cable ducts with cement grout, Anchorage sets in required number with provision for future prestressing if any including all lead and lift with contractor's own materials, labour, equipments etc. complete as per drawings & specifications. Rate also includes covering anchorage pads with epoxy mortar of approved quality to avoid corrosion. Cement for grouting to be paid separately. Payment shall be made in terms of weight of HTS cables as per drawing.	13	MT	179,099.63	232,655.79	3,024,525.27

Schedule 'B'/R1 Other Civil Works							
S. No	Item No.	Description of Item	Quantity	Unit	NWR USSOR/DS R Rate in INR	Estimated rate including GST @ 18 % in INR	Estimated Amount in INR
16	031140	Providing and fixing in position GI Drainage Spouts of required length with Grating in RCC slab and filling bitumen along kerb as shown in drawing with contractor's pipes, bitumen, tools, equipment, lead, lifts etc. complete as per specifications and as directed by Engineer in-charge					
16a	031142	100mm dia. Drainage Spouts	120	Metre	1,202.50	1,348.32	161,798.40
17	041330	Launching & fixing in specified Bridge location all types of Steel Plate girders / PSC girders / Slabs including loading/unloading and transport to the site of launching with a lead of five kilometres & lifting to any height as per site requirement, provision of approaches for leading, cleaning of bed block and minor repairs to bed block with epoxy if required, as directed by Engineer in charge with all labour, tools and plant, equipment etc., complete					
17a	041331	PSC girders / slabs	910	MT	6,346.14	7,115.72	6,475,305.20

Schedule 'B'/R1 Other Civil Works							
S. No	Item No.	Description of Item	Quantity	Unit	NWR USSOR/DS R Rate in INR	Estimated rate including GST @ 18 % in INR	Estimated Amount in INR
18	041390	Supplying fabricating and erecting welded and/or bolted and/or riveted steel work in built up sections, trusses and framed work, staging, racks etc.for Steel Structures other than bridge girders, using RSJ, tees, angles and channels/flats, plates, gussets, round or square bars, cleats, bolts etc., with contractors own steel including cutting, bending, straightening, drilling, riveting, hoisting, fixing, erecting, welding, bolting etc., with Providing stiffeners wherever required as per approved drawing including applying a priming coat of a approved steel primer with all contractor's materials, labour, tools & plants, lead & lift including crossing of tracks if required etc., complete as per specification and as directed by Engineer-in-charge.	70	MT	86,019.71	122,227.99	8,555,959.30
19	051170	Providing and laying of filter media consisting of granular materials of GW, GP, SW groups as per IS:1498 (latest) in required profile behind boulder filling of abutments, wing walls / return walls etc. above bed level with all labour and material complete job as per drawing and technical specification of RDSO Guidelines.	8,500	Cum	2,658.72	2,587.70	21,995,450.00

Schedule 'B'/R1 Other Civil Works							
S. No	Item No.	Description of Item	Quantity	Unit	NWR USSOR/DS R Rate in INR	Estimated rate including GST @ 18 % in INR	Estimated Amount in INR
20	052230	Providing cast in situ bridge number plaques as per Railway drawing in cement concrete 1:2:4 mix using 20mm hard stone aggregate embedded in 30mm notch in Bridge parapet coping duly engraving the letter and figures and an arrow indicating the direction of flow and finishing the top exposed surface with cement mortar 1:3, painting letters and figures with two coats of black enamel paint on two coats of white background with all labour, tools, cement, paint etc. with all leads and lifts.	5	Each	801.69	898.91	4,494.55
21	052240	Providing cast in-situ plaques for bridge foundations details of size 45cmx45cmx5cm in cement concrete 1:2:4 mix using 20mm hard stone aggregate embedded in 30mm deep notch over abutment & piers, engraving the letters & figures with CM 1:3 and finished smooth including painting letters and figures with 2 coats of black enamel and plaque with white enamel with all labour, tools, cement, paint, curing etc. as a complete job.	10	Each	1,049.88	1,177.20	11,772.00
Schedule B2:- DSR-2021 BASED ITEMS							
22	10.16	Steel work in built up tubular (round, square or rectangular hollow tubes etc.) trusses etc., including cutting, hoisting, fixing in position and applying a					

Schedule 'B'/R1 Other Civil Works							
S. No	Item No.	Description of Item	Quantity	Unit	NWR USSOR/DS R Rate in INR	Estimated rate including GST @ 18 % in INR	Estimated Amount in INR
		priming coat of approved steel primer, including welding and bolted with special shaped washers etc. complete.					
22a	10.16.2	Hot finished seamless type tubes	2,000	Kg	168.95	183.55	367,100.00
23	10.28	Providing and fixing stainless steel (Grade 304) railing made of Hollow tubes, channels, plates etc., including welding, grinding, buffing, polishing and making curvature (wherever required) and fitting the same with necessary stainless steel nuts and bolts complete, i/c fixing the railing with necessary accessories & stainless steel dash fasteners , stainless steel bolts etc., of required size, on the top of the floor or the side of waist slab with suitable arrangement as per approval of Engineer-in-charge, (for payment purpose only weight of stainless steel members shall be considered excluding fixing accessories such as nuts, bolts, fasteners etc.).	800	Kg	612.25	665.14	532,112.00
24	16.30.2	Providing and applying tack coat using hot straight run bitumen of grade VG - 10, including heating the bitumen, spraying the bitumen with mechanically operated spray unit fitted on bitumen boiler, cleaning and preparing the existing road surface as per	4,252	Sqm	36.60	39.76	169,059.52

Schedule 'B'/R1 Other Civil Works							
S. No	Item No.	Description of Item	Quantity	Unit	NWR USSOR/DS R Rate in INR	Estimated rate including GST @ 18 % in INR	Estimated Amount in INR
		specifications On bituminous surface @ 0.50 Kg / sqm					
25	16.33.2	2.5 cm premix carpet surfacing with 2.25 cum and 1.12 cum of stone chippings of 13.2 mm and 11.2 mm size respectively per 100 sqm and 52 kg and 56 kg of hot bitumen per cum of stone chippings of 13.2 mm and 11.2 mm size respectively, including a tack coat with hot straight run bitumen, including consolidation with road roller of 6 to 9 tonne capacity etc. complete (tack coat to be paid for separately). With paving Asphalt grade VG - 30 with no solvent	4,125	Sqm	254.80	276.81	1,141,841.25
26	16.40	Providing and laying seal coat of premixed fine aggregate (passing 2.36 mm and retained on 180 micron sieve) with bitumen using 128 kg of bitumen of grade VG - 10 bitumen per cum of fine aggregate and 0.60 cum of fine aggregate per 100 sqm of road surface, including rolling and finishing with road roller all complete	4,125	Sqm	79.85	86.75	357,843.75

Schedule 'B'/R1 Other Civil Works							
S. No	Item No.	Description of Item	Quantity	Unit	NWR USSOR/DS R Rate in INR	Estimated rate including GST @ 18 % in INR	Estimated Amount in INR
27	16.55.1	Providing and laying bituminous macadam using crushed stone aggregates of specified grading premixed with bituminous binder, transported to site by tippers, laid over a previously prepared surface with paver finisher equiped with electronic sensor to the required grade, level and alignment and rolling with smooth wheeled, vibratory and tandem rollers as per specifications to achieve the desired compaction and density, complete as per specifications and directions of Engineer-in-Charge. 50 to 100 mm average compacted thickness with bitumen of grade VG-30 @ 3.50% (percentage by weight of total mix) prepared in Batch Type Hot Mix Plant of 100-120 TPH capacity.	1,200	Cum	7,756.40	8,426.50	10,111,800.00
28	16.69	Providing and laying at or near ground level factory made kerb stone of M-25 grade cement concrete in position to the required line, level and curvature, jointed with cement mortar 1:3 (1 cement: 3 coarse sand), including making joints with or without grooves (thickness of joints except at sharp curve shall not to more than 5mm), including making drainage opening wherever required complete etc. as per direction of Engineer-in-charge (length of finished kerb edging shall be measured for payment).	20	Cum	8,613.55	9,357.71	187,154.20

Schedule 'B'/R1 Other Civil Works							
S. No	Item No.	Description of Item	Quantity	Unit	NWR USSOR/DS R Rate in INR	Estimated rate including GST @ 18 % in INR	Estimated Amount in INR
		(Precast C.C. kerb stone shall be approved by Engineer-in-charge).					
29	16.75	Providing and laying C.C. pavement of mix M-25 with ready mixed concrete from batching plant. The ready mixed concrete shall be laid and finished with screed board vibrator , vacuum dewatering process and finally finished by floating, brooming with wire brush etc. complete as per specifications and directions of Engineer-in-charge. (Note:- Cement content considered in this item is @ 330 kg/cum. Excess/less cement used as per design mix is payable/ recoverable separately).	220	Cum	8,277.55	8,992.68	1,978,389.60
30	16.78.2	Construction of granular sub-base by providing close graded Material conforming to specifications, mixing in a mechanical mix plant at OMC, carriage of mixed material by tippers to work site, for all leads & lifts, spreading in uniform layers of specified thickness with motor grader on prepared surface and compacting with vibratory power roller to achieve the desired density, complete as per specifications and directions of Engineer-in-Charge. With material	600	Cum	2,775.65	3,015.45	1,809,270.00

Schedule 'B'/R1 Other Civil Works							
S. No	Item No.	Description of Item	Quantity	Unit	NWR USSOR/DS R Rate in INR	Estimated rate including GST @ 18 % in INR	Estimated Amount in INR
		conforming to Grade-II (size range 53 mm to 0.075 mm) CBR Value-25					
31	16.79	Providing, laying, spreading and compacting graded stone aggregate (size range 53 mm to 0.075 mm) to wet mix macadam (WMM) specification including premixing the material with water at OMC in for all leads & lifts, laying in uniform layers with mechanical paver finisher in sub- base / base course on well prepared surface and compacting with vibratory roller of 8 to 10 tonne capacity to achieve the desired density, complete as per specifications and directions of Engineer-in-Charge	550	Cum	2,803.65	3,045.87	1,675,228.50
32	16.91	Providing and laying factory made chamfered edge Cement Concrete paver blocks in footpath, parks, lawns, drive ways or light traffic parking etc, of required strength, thickness & size/ shape, made by table vibratory method using PU mould, laid in required colour & pattern over 50mm thick compacted bed of sand, compacting and proper embedding/laying of inter locking paver blocks into the sand bedding layer through vibratory compaction by using plate vibrator, filling the joints with sand and cutting of paver blocks as per required size and					

Schedule 'B'/R1 Other Civil Works							
S. No	Item No.	Description of Item	Quantity	Unit	NWR USSOR/DS R Rate in INR	Estimated rate including GST @ 18 % in INR	Estimated Amount in INR
		pattern, finishing and sweeping extra sand. complete all as per direction of Engineer-in-Charge.					
32a	16.91.1	60 mm thick C.C. paver block of M-30 grade with approved color design and pattern.	450	SQM	932.35	1,012.90	455,805.00
33		Items included in Delhi Schedule of Rate- (Horticulture & Landscaping) 2020		LS			1,060,000.00
Schedule B3:- NS BASED ITEMS							
34	NS-1	Earthwork in filling with contractor's own earth of approved quality from borrow areas including all lead all lead, lift, ascent, descent, royalty, taxes, cess, compensation, crossing of nallahs /stream and other obstructions including mechanical compaction in layers with watering to 95% of MDD (as per IS 2720 part 8), handling, re-handling, dressing to the final profile with all labour, material, tools, plant, machinery and equipment, taxes, cess etc. as a complete job in accordance with the specification and drawings.	2,000	Cum	271.46	287.75	575,500.00

Schedule 'B'/R1 Other Civil Works							
S. No	Item No.	Description of Item	Quantity	Unit	NWR USSOR/DS R Rate in INR	Estimated rate including GST @ 18 % in INR	Estimated Amount in INR
35	NS-2	Supplying and laying in position M-35 RCC as per approved design mix with admixtures and manufactured in fully automatic batching plant and transported to site of work in transit mixer for all lifts & leads, having continuous agitated mixer, pumping concrete from transit mixer to site of laying, compacting, finishing & curing, with all labour, material, tools, plants, machinery and equipment, taxes, cess etc., as a complete job ,but excluding supplying & fixing form work (centring & shuttering),in accordance with the specification and drawings.Note – (i) Cost of cement is included in the above item.(ii) Cost of Reinforcement steel is not included in the above item and will be paid separately under item no.8(I) (USSOR item No. 025072)(iii) Cost of supplying & fixing form work (centring & shuttering) is not included in the above item (except pile cap & open foundation) and will be paid separately under relevant item no. 6(i),(ii),(iii) (USSOR item No. 025030)					
35a	NS-2A	In Pile caps, open foundation & RCC Box/Sub way, well steining, well cap	4,935	Cum	7,776.37	8,242.95	40,678,958.25
35b	NS-2B	In Piers, abutments, box	960	Cum	8,098.18	8,584.07	8,240,707.20

Schedule 'B'/R1 Other Civil Works							
S. No	Item No.	Description of Item	Quantity	Unit	NWR USSOR/DS R Rate in INR	Estimated rate including GST @ 18 % in INR	Estimated Amount in INR
35c	NS-2C	Abutment cap & Pier Cap, pedestals, approach slab, Deck slab	460	Cum	8,421.36	8,926.64	4,106,254.40
35d	NS-2D	Retaining walls, wing walls, return walls, drop walls, curtain walls, toe walls etc. of all heights	700	Cum	7,888.74	8,362.06	5,853,442.00
36	NS-3	Providing Boulder Backing behind wing wall, return wall, retaining wall with hand packed boulders & cobbles not less than 15cm in any direction & not less than 15kg (except smaller boulders required for filling voids) including all lead, lift, labour & other incidental charges as complete work in all respect. Cost of boulder/cobbles is included in this item.	1,900	Cum	1,475.82	1,564.37	2,972,303.00
37	NS-4	Providing and fixing of 75mm dia PVC pipe for weep holes in abutments, Wing Wall, Return Wall, Face wall, retaining wall etc. at suitable intervals as directed by the Engineer-in-charge.	1,000	Rmt	231.00	244.86	244,860.00

Schedule 'B'/R1 Other Civil Works							
S. No	Item No.	Description of Item	Quantity	Unit	NWR USSOR/DS R Rate in INR	Estimated rate including GST @ 18 % in INR	Estimated Amount in INR
38	NS-5	<p>Casting, supplying and installation of Pre-cast cement concrete blocks of size 25X25 X20cm. or of required size as directed by the Engineer for protective works at bridges & banks like pitching, toe wall, flooring, drains etc. using M20 design concrete mix with 20mm aggregate size including Contractor's shuttering, leading to bridge site from casting depot, including dressing and levelling of surface, providing gravel backing, laying & jointing blocks with cement mortar 1:3 with Contractor's labour and as directed by Engineer-in-charge (All labour and materials including cement by Contractor).</p> <p>Note:</p> <p>i) Payment for gravel backing will be paid under item no. NS-6 of this Bill.</p> <p>ii) 60% Payment shall be made after casting of pre-cast concrete blocks and bringing at work site. The balance 40% will be made on completion of laying and finishing.</p> <p>iii) Measurement is based on quantity calculation of blocks used only (no of blocks x volume of one block).</p>	1,400	Cum	7,731.14	8,195.01	11,473,014.00

Schedule 'B'/R1 Other Civil Works							
S. No	Item No.	Description of Item	Quantity	Unit	NWR USSOR/DS R Rate in INR	Estimated rate including GST @ 18 % in INR	Estimated Amount in INR
39	NS-6	Supplying and laying of 150mm thick well graded stones aggregate/gravel as base layer over the slopes of embankment with manual dressing with water compaction including the cost of supply of all material, labour, lead, lift, tools, plants, crossing of tracks etc. complete as per approved drawings and technical specifications.	1,080	Cum	2,139.90	2,268.29	2,449,753.20
40	NS- 7	Supply & installation of precoated galvanized iron profile sheets (size, shape and pitch of corrugation as approved by Engineer-in-charge) 0.50mm +/- 5% total coated thickness (TCT) thick Zinc coating 120gsm as per IS:277 in 240mpa steel grade, 5-7microns epoxy primer on both side of the sheet and polyester top coat 15-18 microns. Sheet should have protective guard film of 25 microns minimum to avoid scratches while transportation and should be supplied in single length upto 12 metre or as desired by Engineer-in-charge. The sheet shall be fixed using self drilling / self tapping screws of size (5.5 x 55mm) with EPDM seal or with polymer coated J or L hooks, bolts and nuts 8mm diameter with bitumen and G.I. limpet washers or with G.I. limpet washers filled with white lead complete upto any pitch in horizontal/vertical or curved surfaces excluding the	100	Sqm	756.52	801.91	80,191.00

Schedule 'B'/R1 Other Civil Works							
S. No	Item No.	Description of Item	Quantity	Unit	NWR USSOR/DS R Rate in INR	Estimated rate including GST @ 18 % in INR	Estimated Amount in INR
		cost of purlins, rafters and trusses and including cutting to size and shape wherever required.					
41	NS-8	Ø25 SN Bolts (Cement grouted): Supply, drilling, installation and grouting of SN type rockbolts of the specified length, Yield strength ≥ 500 MPa (slopes, tunnel support & face bolts) as per approved drawings and Specifications or as directed by Engineer, with contractors men, material, consumables, plants, equipments, machineries, including all lead & lifts loading, unloading etc required for the complete job.	4,500	Rmt	430.25	456.07	2,052,315.00
42	NS-9	Wire Mesh: Supply, cutting, placing and fixing into position with appropriate anchors of 150x150x6 mm or 100x100x4 mm welded wire fabric of $F_y=480$ MPa as reinforcement in primary lining & inner lining with contractors men, material, cost of pins, hooks, consumables, tools & plants, equipments, machineries, including all lead & lifts, loading, unloading, handling complete job.	11	MT	77408	82,052.48	902,577.28

Schedule 'B'/R1 Other Civil Works							
S. No	Item No.	Description of Item	Quantity	Unit	NWR USSOR/DS R Rate in INR	Estimated rate including GST @ 18 % in INR	Estimated Amount in INR
43	NS-10	M30 Shotcrete : Shotcreting with wiremesh/fibers as per design Primary lining :Shotcrete for primary (outer) lining of Tunnel or Niches, grade M30, including face sealing shotcrete, temporary invert, filling of cavities, widening of top heading footing in tunnel and slope stabilization and in open excavation etc. Note: The Dry shotcrete shall also be payable under this item.	250	Cum	10269	10,885.14	2,721,285.00
44	NS-11	Supply of structural steel for steel ribs of various sections confirming IS 2062 of Grade-A from approved manufacturers at various sites including all transportation and freight charges and all taxes, duties etc. with contractors men, material, tools & plants, equipments, machineries, testing, all lead & lifts, loading , unloading , etc complete	4	MT	77968.38	82,646.48	330,585.92

Schedule 'B'/R1 Other Civil Works							
S. No	Item No.	Description of Item	Quantity	Unit	NWR USSOR/DS R Rate in INR	Estimated rate including GST @ 18 % in INR	Estimated Amount in INR
45	NS-12	Steel Ribs: Fabrication and erection in position permanent tunnel steel ribs including of variable geometry and or member size as per design/assembly, using structural steel Grade A, Yield stress ≥ 250 MPa with all accessories such as bolt/nuts, washers, plates, tie rods etc., including cutting, drilling, cold bending, welding, threading, leveling, aligning and fixing in position of all rods, gusset/ wall plates, pre-stressing by blocking against rock-surface etc. as per approved drawings and Specifications or as directed by Engineer with contractor's men, material, consumables, tools and plants, equipments, machineries, including all lead and lift, loading, unloading. Rate to cover supports & scaffoldings required during the course of erection etc. complete. Note: Payment for supply of structural steel shall be paid as per approved drawing (excluding all wastages) separately as per item NS-11.	1	MT	9944	10,540.64	10,540.64

Schedule 'B'/R1 Other Civil Works							
S. No	Item No.	Description of Item	Quantity	Unit	NWR USSOR/DS R Rate in INR	Estimated rate including GST @ 18 % in INR	Estimated Amount in INR
46	NS-13	Lattice Girders: Fabrication and erection of lattice girders using high strength reinforcing steel Fe-500D with all accessories such as bolt/nuts, washers, plates, tie rods etc, including all lead, lift, wastage, storing, drilling holes, fixing in phases etc. and installation of accessories for joining the Lattice girder segments and fixing into place as per approved drawings and Specifications or as directed by Engineer. The rate shall include costs of all materials except as noted below, labour, equipment, welding, etc for the complete job including additional cost for enlargement of top heading footing. (Payment for supply of reinforcement steel (excluding all wastages) will be made separately as per item NS-11)	3	MT	9944	10,540.64	31,621.92
47	NS-14	Providing, fabricating & laying of colour coated galvalume (Proflex system roofing)material for self supported roofing system, material shall be of following specification, BMT 0.90mm to 1.00mm,APT 0.95mm tolerance +/- 0.02mm thick ,Width 605 mm or as decided by railway (Tolerance +/- 2mm),including supplying, loading ,transporting, uploading & stacking at site ,fabricating and laying with all contractors tools, plants, machineries materials and fixtures labours including all lead and	100	Sqm	2370.98	2,513.24	251,324.00

Schedule 'B'/R1 Other Civil Works							
S. No	Item No.	Description of Item	Quantity	Unit	NWR USSOR/DS R Rate in INR	Estimated rate including GST @ 18 % in INR	Estimated Amount in INR
		lift and laps/wastage if any etc. complete. The colour of sheet will be decided by Engineer. The rate is also inclusive of designing of roofing system, proof checking and providing execution drawing. Fabrication and installation of self supported roofing.					
Total Amount of Schedule 'B'							3s89,447,602.42

8 Schedule C/R1: Item rate for miscellaneous works

Schedule 'C'/R1 Item rate for miscellaneous works						
S. No	Item Reference DSR-21/USSOR- 2019 (NWR)/NS	Description of Item	Unit	Basic Rate in INR	Add % Above for Estimate	Estimated Rate in INR
DSR-21 Items						
1	DSR-21 19.35	Providing and laying Non Pressure NP-3 class (Medium duty) R.C.C. pipes including collars/spigot jointed with stiff mixture of cement mortar in the proportion of 1:2 (1 cement : 2 fine sand) including testing of joints etc. complete.				
I	19.35.1	450mm dia. RCC pipes	Metre	2385.5	8.64%	2,591.61
II	19.35.2	600 mm dia RCC pipes.	Metre	3051.55	8.64%	3,315.20
2	DSR-21 19.6	Providing and laying non-pressure NP2 class (light duty) R.C.C. pipes with collars jointed with stiff mixture of cement mortar in the proportion of 1:2 (1 cement : 2 fine sand) including testing of joints etc. complete :				
I	19.6.1	100 mm dia. R.C.C. pipe	Metre	447.25	8.64%	485.89
II	19.6.2	150 mm dia. R.C.C. pipe	Metre	493.1	8.64%	535.70
III	19.6.3	250 mm dia. R.C.C. pipe	Metre	811	8.64%	881.07

Schedule 'C'/R1						
Item rate for miscellaneous woks						
S. No	Item Reference DSR-21/USSOR- 2019 (NWR)/NS	Description of Item	Unit	Basic Rate in INR	Add % Above for Estimate	Estimated Rate in INR
3	DSR-2021 16.90	Providing and laying tactile tile (for vision impaired persons as per standards) of size 300x300x9.8mm having with water absorption less than 0.5% and conforming to IS:15622 of approved make in all colours and shades in for outdoor floors such as footpath, court yard, multi modals location etc., laid on 20mm thick base of cement mortar 1:4 (1 cement : 4 coarse sand) in all shapes & patterns including grouting the joints with white cement mixed with matching pigments etc. complete as per direction of Engineer-in-Charge.	Sqm	1719	8.64%	1,867.52
4	DSR-21 11.26	Kota stone slab flooring over 20 mm (average) thick base laid over and jointed with grey cement slurry mixed with pigment to match the shade of the slab, including rubbing and polishing complete with base of cement mortar 1: 4 (1cement : 4 coarse sand) Cost of cement is included in this item.				
I	11.26.1	25 mm thick	Sqm	1706.6	8.64%	1,854.05
USSOR-2019(NWR) Items						

Schedule 'C'/R1						
Item rate for miscellaneous woks						
S. No	Item Reference DSR-21/USSOR- 2019 (NWR)/NS	Description of Item	Unit	Basic Rate in INR	Add % Above for Estimate	Estimated Rate in INR
5	USSOR- 2019(NWR) 031110	Load testing of one or more spans of bridge as selected by the Engineer as per approved load test procedure following relevant IS/IRC/Railway codes with contractor's labour, deflection measuring instruments, loading materials, recoding and analyzing the load testing results including all lead & lift, etc. complete as required. The rates are all inclusive and will be paid after load test is finished and girder is cleared of the kentledges/loading material etc. The load shall be 1.25 times the stipulated design load.				
I	031111	For Span design load upto 100 MT	Each	85662.09	12.13%	96,052.90
II	031112	Extra for every increase 1 MT or part thereof in the span design load capacity upto 800 MT	MT	845.81	12.13%	948.41

Schedule 'C'/R1						
Item rate for miscellaneous woks						
S. No	Item Reference DSR-21/USSOR- 2019 (NWR)/NS	Description of Item	Unit	Basic Rate in INR	Add % Above for Estimate	Estimated Rate in INR
6	021010	Exploratory drilling of boreholes down to required depth, drilling of 150mm dia. boreholes in all type of soils except hard rock & large boulders (boulder core more than 30cm) including refilling, reinstating surface and disposing off surplus material including use of mechanical rigs with power operated winches as well as percussion/chiselling tool for advancing through occasional seams of hard strata to be employed, where necessary in Dry area.				
I	021011	0m to 10m	Metre	1,213.51	12.13%	1,360.71
II	021012	10m to 20m	Metre	1,296.46	12.13%	1,453.73
III	021013	20m to 30m	Metre	1,431.59	12.13%	1,605.24
IV	021014	30m to 40m	Metre	1,554.68	12.13%	1,743.26
7	021050	<i>Drilling of NX size borehole (75mm dia.) in all types of hard rock and collection of rock core samples from boreholes and preserving in boxes</i>				
I	021051	0m to 10m	Metre	3,189.64	12.13%	3,576.54
II	021052	10m to 20m	Metre	3,418.43	12.13%	3,833.09
III	021053	20m to 30m	Metre	3,775.66	12.13%	4,233.65

Schedule 'C'/R1						
Item rate for miscellaneous woks						
S. No	Item Reference DSR-21/USSOR- 2019 (NWR)/NS	Description of Item	Unit	Basic Rate in INR	Add % Above for Estimate	Estimated Rate in INR
8	021060	<i>Conducting in-situ full size Plate Load Test (PLT) at selected location as per IS:1888 including making loading arrangements & casting of RCC/cast in-situ concrete footing as per codal provisions including excavation and refilling of trial pit</i>				
<i>I</i>	021062	<i>Plate size 45cm x 45cm</i>	<i>Each</i>	<i>27,754.18</i>	<i>12.13%</i>	<i>31,120.76</i>
<i>II</i>	021063	<i>Plate size 60cm x 60cm</i>	<i>Each</i>	<i>31,000.02</i>	<i>12.13%</i>	<i>34,760.32</i>
9	021080	<i>Conducting SCPT for soil as per IS:4968</i>	<i>Each</i>	<i>47,313.49</i>	<i>12.13%</i>	<i>53,052.62</i>
10	021090	<i>Conducting DCPT for soil as per IS:4968</i>	<i>Each</i>	<i>37,394.02</i>	<i>12.13%</i>	<i>41,929.91</i>
11	021110	<i>Taking out 100mm dia. & 450mm long undisturbed samples of soil from bore holes, including provision of air tight containers for packing and, labelling incl. transporting the samples to laboratory. Piston sampler shall be used for extracting undisturbed samples where necessary. Samples shall be collected as per IS:2720.</i>	<i>Each</i>	<i>152.52</i>	<i>12.13%</i>	<i>171.02</i>
12	021120	<i>Taking out 100mm dia. & 450mm long disturbed samples of soil from bore holes, including provision of air tight containers for packing, labelling and transporting the samples to laboratory. Samples shall be collected as per IS:2720.</i>	<i>Each</i>	<i>164.57</i>	<i>12.13%</i>	<i>184.53</i>

Schedule 'C'/R1						
Item rate for miscellaneous woks						
S. No	Item Reference DSR-21/USSOR- 2019 (NWR)/NS	Description of Item	Unit	Basic Rate in INR	Add % Above for Estimate	Estimated Rate in INR
13	021130	Conducting standard penetration test as per IS:2131 at approximate 1.5m intervals in bore holes, as directed by the Engineer in charge	Each	852.27	12.13%	955.65
14	021150	Conducting laboratory Tests on collected soil samples as per relevant IS code				
I	021151	Moisture Content/Dry Density	Each	287.66	12.13%	322.55
II	021152	Atterberg Limits	Each	586.02	12.13%	657.10
III	021153	Specific Gravity	Each	631.51	12.13%	708.11
IV	021154	Grain size analysis including Hydrometer analysis	Each	731.85	12.13%	820.62
V	021155	Direct Shear Test	Each	2,140.70	12.13%	2,400.37
VI	021156	Natural Density	Each	709.11	12.13%	795.13
VII	021157	Consolidation Test	Each	6,886.37	12.13%	7,721.69
VIII	021158	Unconfined Compression Test	Each	2,006.91	12.13%	2,250.35
IX	021159	Tri-axial Test	Each	2,408.29	12.13%	2,700.42
NS Items						
15	NS-1	Boring 1200 mm diameter piles using Hydraulic Rig in all kinds of strata including boulder studded soil, underground structure like channel, sewer manholes, old foundation or any other obstruction, irrespective of sub-soil water level in all conditions whether dry or under water, shoe and temporary	Rmt	10,232.00	6.00%	10,845.92

Schedule 'C'/R1 Item rate for miscellaneous woks						
S. No	Item Reference DSR-21/USSOR- 2019 (NWR)/NS	Description of Item	Unit	Basic Rate in INR	Add % Above for Estimate	Estimated Rate in INR
		<i>casing pipe, if required, with contractor plant, machinery & equipment for pile boring, use of bentonite slurry including all operations, cleaning of bore holes, supplying and laying in-situ with tremie pipe M-35 RCC in piles as per approved design mix with admixtures and manufactured in fully automatic batching plant and transported to site of work in transit mixer for all lifts & leads, having continuous agitated mixer, pumping concrete from transit mixer to site of laying including supplying & fixing form work (centering & shuttering), compacting, finishing, curing, chipping off pile top to remove laitance concrete above cut off level, removal and disposal of surplus excavated earth/debris/muck outside ROW including all lead, lift, ascends, descends, loading, unloading handling, re-handling, crossing of stream, nallahs, railway track, level crossing etc. with all labour, material, tools, plants, machinery and equipment, taxes, cess etc. as a complete job in</i>				

Schedule 'C'/R1 Item rate for miscellaneous woks						
S. No	Item Reference DSR-21/USSOR- 2019 (NWR)/NS	Description of Item	Unit	Basic Rate in INR	Add % Above for Estimate	Estimated Rate in INR
		<p><i>accordance with the Specification and the Drawings.</i></p> <p><i>Note –</i></p> <p><i>i. Cost of cement is included in the above item.</i></p> <p><i>ii. Cost of Reinforcement steel is not included in the above item and will be paid separately under relevant item of Schedule-B.</i></p> <p><i>iii. Cost of temporary casing pipe is included in the above item. However, cost of permanent casing pipe is not included in this item and shall be paid separately under item, if required and approved by the Engineer.</i></p>				

Total Estimated cost of Schedule 'C'- INR 2.00 Crore (INR 20 million).

Tender No. HORC/HRIDC/C-4/2022

Attachment 2 to Corrigendum No. 3

Section VII: Employer's Requirements

Section VII-2: Functional (Civil & BLT)/R1

EMPLOYER'S REQUIREMENTS –FUNCTIONAL (CIVIL & BLT)**OBJECTIVE**

The objective of the Contract is the design, construction completion, testing and commissioning of the permanent works by the Contractor (including without limitation, the design, installation and removal of the Temporary Works) and the rectification of defects appearing in Permanent Works in the manner and to the standards and within the time stipulated by the Contract. In full recognition of this objective, and with full acceptance of the obligations, liabilities and risks which may be involved, the Contractor shall undertake the execution of the Works.

1 GENERAL

- 1.1** *The Works to be executed under Package C-4 is for design and construction of civil works and General electrical services work as per Employer's Requirements on 'Design Build' basis. All information available with the Employer has been furnished in Section VII-8, Tender Drawings and Documents, Part 2, Employer's Requirements. The Works are to be designed by the Contractor. Any other site data and information required for design of the Works shall be collected (through tests or otherwise), arranged, produced by the Contractor at his own cost. No claim from the Contractor whatsoever shall be entertained on the ground of certain information not being furnished in the Contract. The design and performance of the Permanent Works shall comply with the specific core requirements contained in these Employer's Requirements – Functional (Civil &BLT).*
- 1.2** The design of the Permanent Works shall be developed in accordance with these Employer's Requirements – Functional (Civil & BLT) and other requirements of the Contract.
- 1.3** The Permanent Works shall be designed and constructed to the highest standards available using proven up-to-date good Engineering practices. Construction shall be carried out employing the procedures established by the Contractor as per approved Quality Assurance and Quality Control plan and Environmental, Social, Health and Safety (ESHS) Plan.
- 1.4** The Contractor shall be responsible for obtaining all necessary approvals from the relevant Public/Government/Local/Statutory or any agencies in the design and construction of the Works.
- 1.5** Employer's Requirements- Functional (Civil & BLT) shall be read in conjunction with Employer's Requirements-Design, Construction, Outline Design Specification (ODS)-Civil & BLT, Outline Construction Specifications (OCS)-Civil & BLT and other requirements of the Contract. *The price quoted by the Contractor shall be deemed to have included cost of Works as per Part 2-Employer's Requirements (General, Functional (Civil and BLT) , Design (Civil), Construction (Civil) , Outline Design Specifications (ODS)- Civil and BLT ,*

Outline Construction Specifications (OCS)-Civil and BLT , General Electrical Services , Tender drawings and Documents and Appendices).

2 SCOPE OF THE WORKS

2.1 Scope under Lumpsum Price Schedule 'A'

HORC project crosses Aravalli Range between Sohna and Dhulawat stations through a tunnel to be constructed in C-4 Package from Ch.24850 m to Ch.29580 m. The tunnelling is required to be done in rock as well as in soil. It involves tunnelling by NATM method and Cut and Cover method. Two separate tunnels are to be constructed - one for Up line and one for Down line. The tunnel is to be provided with Ballastless track (BLT). NATM work is required to be carried out from fourteen faces as shown in Tender drawings. The tunnel has got four permanent ventilation shafts and one construction cum utility shaft. Tentative location of the shafts and area of land which will be made available to the Contractor for working is shown in Tender drawings. The soil excavated from the tunnel will be used for construction of embankment from Ch. 12000 m to Ch. 18000 m. Bridges *as per list given in Annexure F-1 and Annexure F-2* are also involved in formation from Ch. 12000 m to Ch. 18000 m .

The through Chainages mentioned in the Scope of the Works/Tender drawings can undergo some minor corrections, without any impact on the overall length/Scope of the Works. The Scope of the Works for C-4 Package will be, but not limited to, as follows:

2.1.1 Design and Construction of Twin Tunnel

- a) *Design and construction of Cut & Cover Tunnels from Ch. 28480 m to Ch. 29580 m including drainage arrangements for catering to surface run off from open cutting of about 1340 m length as shown in Tender drawings.*
- b) *Design and construction of NATM twin Tunnels from Ch. 24850 m for UP line and Ch. 24853 m for DN line to Ch. 28480 m in all types of strata (rock and soil) including drainage arrangements for catering to surface run off from open cutting as shown in Tender drawings.*
- c) *Design and construction of four (02x02) Nos. of permanent ventilation shafts and other associated structures including roofing system and stairs as specified in Section VII-5: Outline Design Specifications (ODS)-Civil & BLT, Section VII-6: Outline Construction Specifications (OCS)-Civil & BLT, DBR and Tender drawings.*
- d) *Design and construction of one (01) No. construction cum utility shaft and other associated structures including roofing system and stairs as specified in Section VII-5: Outline Design Specifications (ODS)-Civil & BLT, Section VII-6: Outline Construction Specifications (OCS)-Civil & BLT, DBR and as shown in Tender drawings. Cross passage between two tunnels at the location of construction cum utility shaft shall be provided to accommodate electrical installations as shown in*

Tender drawings.

- e) Design and construction of cross passages at an interval of approximately 350m including fire stop doors at both ends as shown in the Tender drawings.
- f) Design and construction of *Portal P-2 for both UP & DN lines including drainage arrangement at the interface of Portal P2 and Cut & Cover tunnel for catering to surface runoff from the cutting.*
- g) *Design of Portal P-1 for both UP & DN lines including slope stability of rock, boulder fall and protection arrangements.*
- h) Design of *drainage system at Palwal end approach of Portal P-1 for both UP & DN lines for disposal of storm water coming out of the tunnel and from adjoining open area and integrating the drainage system with the drainage scheme of DFC.*
- i) *Design of Abutment A-2 for proposed HORC viaduct for both UP & DN lines including bearing pedestal and seismic restrainers near Portal P-1 as shown in Tender drawings. Construction of Abutment A-2 for both UP & DN lines of viaduct including bearing pedestal and seismic restrainers shall be paid under Schedule 'B'.*

Note-

1. Excavated earth/rock from tunnelling/cutting shall be property of the Contractor. Royalty for using the excavated earth/rock for construction of the Works shall be borne by the Contractor. Surplus excavated earth/rock from tunnel shall be disposed off by the Contractor at his own cost.
2. *The Contractor shall take adequate protection measures for safety of DFC viaduct and ensure its safety during construction (especially during blasting operations and rock cutting) near proposed Portal-P. The Contractor shall ensure that there is no damage caused to DFC viaduct. In case of any damage to DFC viaduct due to failure of the Contractor, the Contractor shall have to repair/restore the viaduct to its original condition at his own cost to the satisfaction of DFC. The Contractor shall ensure that there is no obstruction to operation of DFC track failing which the Contractor shall be responsible for payment of loss/damages caused to DFC on this account. The decision of DFC regarding extent of loss/damages shall be final and binding on the Contractor.*

2.1.2 Design and Construction of Ballastless Track

Design and construction of ballastless track including transition from ballastless track to ballasted track at each end of *tunnel*, and derailment guard from *Ch. 24850m for UP line and Ch. 24853m for DN line to Ch. 29680 m*. The work also includes supply of spare track fittings and maintenance of ballastless track for a period of one year after start of traffic.

2.1.3 Design and construction of railway formation in embankment including protection works

- a) *The Contractor shall design and construct railway formation in embankment for 32.5 t axle load as per RDSO Specifications "Comprehensive Guidelines and specifications*

for Railway Formation- Specification No. RDSO/2020/GE: IRS-0004, Sept 2020” (primarily using excavated material from tunnelling/cutting) from Ch.12000 m to Ch. 18000 m and from abutment A-2 (Ch. 24843.548 m of Up line and Ch. 24847.154m for DN line) of proposed HORC viaduct to Ch. 24850m for UP line and Ch. 24853m for DN line for double track of Main line as shown in Tender drawings and shall include earthwork in filling, subgrade, prepared subgrade and blanketing including mechanical compaction. The Contractor shall arrange borrow areas for earthwork (required in addition to earth obtained from cutting/tunnelling) in embankment at his own cost.

Excavated earth/rock from cutting/tunnelling shall be utilised for formation in embankment/structures in C-4 Package. Royalty for using the excavated earth/rock for construction of the Works shall be borne by the Contractor. Surplus/unsuitable excavated earth/rock shall be disposed off by the Contractor at his own cost.

- b) The Contractor shall design and construct precast RCC longitudinal drains on berms of embankments to collect surface runoff from the slope. Precast RCC chute drains shall be provided at approximately every 50 m for collecting water from drains on berms and discharging it safely away from toe of embankments as shown in Tender drawings. RCC collecting chambers shall be provided at the junction of longitudinal berm drains and precast RCC chute drains.*
- c) The slopes of embankment shall be protected by vegetative cover comprising perennial turf forming grass in accordance with Section VII- 6 Outline Construction Specifications (OCS)-Civil & BLT. On embankments higher than 4 m vegetative cover shall be provided over coir netting as per IS:15869, IS:15872 and IRC: 56.*
- d) After Taking Over the Works, the Contractor shall maintain slopes of embankment, sumps, pre-cast RCC drains on berms, precast RCC chutes drains and vegetative cover for a period of one (01) year and shall make good any loss/damage to slopes of embankment, sumps, pre-cast RCC drains on berms, precast RCC chute drains and vegetative cover due to rain cuts, pedestrian movement or any other reason.*

2.1.4 Design and construction of cutting in the approach of Portal P-2 including protection works

- a) Design and construction of cutting from Portal P-2 to Ch. Km 29.680 or equal to transition length required between BLT and ballasted track in open cutting, whichever is more.*
- b) Design and construction of side drains and catch water drains on both sides of cutting along with two (02) sumps i.e. one (01) No. on outer side of each track at the junction of Portal P-2 and cutting.*
- c) The Contractor shall design and construct precast RCC longitudinal drains on berms of cuttings to collect surface runoff from the slope. Precast RCC chute drains shall be provided at approximately every 50 m for collecting water from drains on berms and discharging it safely into side drains of cuttings as shown in Tender drawings. RCC collecting chambers shall be provided at the junction of longitudinal berm drains and precast RCC chute drains.*

- d) *The slopes of cutting shall be protected by vegetative cover comprising perennial turf forming grass in accordance with Section VII- 6 Outline Construction Specifications (OCS)-Civil & BLT. On cuttings deeper than 4 m vegetative cover shall be provided over coir netting as per IS:15869, IS:15872 and IRC: 56.*
- e) *After Taking Over the Works, the Contractor shall maintain slopes of cutting, sumps, pre-cast RCC drains on berms, side drains, catchwater drains, precast RCC chute drains and vegetative cover for a period of one (01) year and shall make good any loss/damage to slopes of cutting including sumps, pre-cast RCC drains on berms, side drains, catchwater drains, precast RCC chute drains and vegetative cover due to rain cuts, pedestrian movement or any other reason.*
- f) *Inspection steps shall be provided on both sides of cutting for escape of passengers in case of emergency as shown in Tender drawings.*

2.1.5 Design and construction of minor bridges

*The Contractor shall design and construct minor bridges (RUBs, canal and waterway bridges) including protection works on bridge approaches and height gauges at all RUBs as per Employer's Requirements. List of minor bridges is given in **Annexure-F-1**. Approach road on both sides of RUBs shall be designed and constructed by the Contractor upto ROW of HORC for full clear width of RUB. Design and construction of permanent diversion at RUBs shall be carried out by the Contractor as shown in the Tender drawings.*

2.1.6 Design and construction of major bridge

*The Contractor shall design and construct major bridges (RUBs, canal and waterway bridges) including protection works on bridge approaches and height gauges at all RUBs as per Employer's Requirements. List of major bridges is given in **Annexure- F-2**. Approach road on both sides of RUBs shall be designed and constructed by the Contractor upto ROW of HORC for full clear width of RUB. Design and construction of permanent diversion at RUBs shall be carried out by the Contractor as shown in the Tender drawings.*

- 2.1.7** Design and construction of RCC hume pipe (NP-4) of 450 mm dia/precast RCC box (500mm x 500mm, clear opening) in the embankment from Ch. 12000 m to Ch. 18000 m at approximately 500m interval for crossing utilities in future.
- 2.1.8** Design of bridges *including protection works* as given in **Annexure-F-3**. Construction of these bridge shall be paid under Schedule 'B'.
- 2.1.9** All temporary Works associated with construction of the Works, including construction and maintenance of site office(s) *and Resting accommodation* for Engineer's/Employer's staff complete in all respects as per the details given in the Employer's Requirement (Appendix

10 of Section VII-9: Appendices) to the satisfaction of the Engineer for the duration of the Contract.

- 2.1.10** *The Contractor shall provide and maintain during progress of works barricading around the work area where vehicular or pedestrian traffic passes with all safety measures as shown in Tender drawings. The excavations near habitations/public movement areas and all works along the roads shall be provided with proper caution signs and marked with red lights, reflectors at night to avoid accidents near public places to ensure safety of public.*
- 2.1.11** *Traffic management along the work site including construction works required in connection with traffic management like road works, footpaths, drains and other services etc. and repair and maintenance of these construction works during construction period. Any road widening / diversion along with associated drainage system required to facilitate the movement of traffic and their repair & maintenance shall also be carried out by the Contractor. It also includes reinstatement of land/structure/roads/services etc. to original condition wherever road diversion has been made outside original road including reconstruction of structure demolished for traffic management. Materials and other specification related to traffic control devices shall conform to IRC standards.*
- 2.1.12** *Reinstatement/Restoration of roads and services with new material of similar specification as per codal requirement after completion of work for the area disturbed by the Contractor during construction activities. However, reinstatement of roads and its drainage system will be as per current standards being used by the roads/service owning agency for similar roads. Proper survey to be done before dismantling of any of the above services along with extensive photographs, videos & sample of these services by the Contractor & get it verified by the representative of Engineer so as to ascertain the extent of these existing services and its specification.*
- 2.1.13** *If protection works and drainage arrangements of DFC viaduct near portal P1 are required to be dismantled or get damaged during execution of the Works, the same shall be reinstated in original condition by the Contractor at his cost.*
- 2.1.14** *Surveying, instrumentation and monitoring for settlement of buildings, structures, transmission towers and risk analysis, settlement prediction, preventive and corrective actions as per Section VII-5: Outline Design Specifications (ODS)-Civil &BLT.*
- 2.1.15** *All interfacing works with the Interfacing Contractors as defined in the Appendix 5 of the Contract.*
- 2.1.16** *The Contractor shall be responsible for obtaining approval of drawings of bridges and structures by all relevant authorities through the Employer, if required.*
- 2.1.17** *For details of scope of “General Electrical Services” under lumpsum component of the Works refer Section VII-7: General Electrical Services, Part 2 -Employer’s Requirements.*
- 2.1.18** *There is possibility of some of the items not getting mentioned in the above list of works. Tenderers are requested to go through the Tender drawings also in details as the works*

listed in Clause 2.1 above as well as indicated in the Tender drawings would be considered inclusive in the scope of work under lump sum quoted price except the items mentioned in Sub-Clause 2.2, 2.3 and 2.4 below unless specified otherwise in the Contract. Engineer's decision shall be final in this regard in case of dispute.

2.1.19 The work content against the lump sum component of the work shall also include, but not limited to, the following:

- a) Site clearance and dismantling of obstructions etc., before commencement of work as specified or as directed by the Engineer;
- b) True and proper setting out and layout of the Works, benchmarks and provision of all necessary labour, instruments and appliances in connection therewith as specified or as directed by the Engineer;
- c) All aspects of quality assurance, including testing of materials as per the approved inspection and test plan and other components of the work, as specified or as directed by the Engineer;
- d) Day to day cleaning of worksite throughout the execution period;
- e) *Maintenance of the completed Works during the period as specified or as directed by the Engineer*
- f) Submission of completion (i.e., 'As-Built') drawings 06 (Six) sets in A-1 size and all other related documents as specified including scanned and AutoCAD copy with soft copies in both formats of all As-built drawings & documents.
- g) *Preparing Definitive Design, Construction Reference drawings, Good For Construction(GFC) drawings and working drawings for various components of the works and obtaining approval in respect thereof from the Engineer, inclusive of incorporation of all modifications, alterations, changes, etc. that may be required to be carried out as directed by the Engineer;*
- h) *Compliance of requirements of Environmental, Social, Health and Safety (ESHS) Manual as per Appendix 13 of Employer's Requirements, Section VII-9*
- i) *Results of sub-surface investigations conducted at project site are enclosed with the Tender documents. This information about the soil and sub-soil water conditions is being made available to the Contractor in good faith and the Contractor shall have to obtain the details of sub soil parameters independently. No claim whatsoever on account of any discrepancy/variation in soil parameters, sub soil water conditions and change in geology that may be actually encountered at the time of execution of the work and those given in these Tender Documents shall be admissible to the Contractor under any circumstances.*

2.1.20 ASSOCIATED WORKS

Works to be performed shall also include all general works, preparatory works for the construction and works of any kind necessary for the design and satisfactory construction, completion and maintenance of the works to the intent and meaning of the drawings adopted and Outline Construction Specifications, to best Engineering standards and orders that may be issued by the Engineer from time to time, compliance with all Conditions of Contract, supply of all materials, apparatus, plants, equipment, tools, fuel, water, strutting, timbering, transport, offices, stores, workshop, staff, labour and the provision of proper and sufficient protective works, diversion, temporary fencing, lighting and watching required for the safety of the public and protection of works on adjoining land; first-aid equipment, sanitary accommodation for the staff and workmen, effecting and maintenance of all insurances, the payment of all wages, salaries, fees, royalties, duties or the other charges arising out of the execution of works and the regular clearance of rubbish, clearing up, leaving the site perfect and tidy on completion.

2.1.21 CONTRACTOR'S FACILITIES & SITE OFFICE

Land as shown in Section VII-8: Tender drawings and documents, Part 2-Employer's Requirements will be made available by the Employer which can be utilised by the Contractor for Contractor's facilities and site office (excluding labour camps) with the approval of the Engineer. Any land required beyond the above area will have to be arranged by the Contractor at his own cost. This land shall be made good for such offsite activities as needed by the Contractor at no extra cost to the Employer. The land shall be cleared from debris, all structures made by the contractor including, RCC footings and rafts etc. and reinstated to the line, level and to the same conditions as existed before the work started before handing over back to the Employer within 91 days after Taking over Certificate. The final bill shall be released to the contractor after all structures from the Contractor facility and site office are removed & clearance of site. The cost of setting up of all the above mentioned facilities & the office and reinstatement of site is included in lump sum price in Schedule 'A'.

2.2 Scope under BOQ Schedule 'B'

Under this Schedule, the Contractor is required to carry out works which are not covered in Schedule 'A'. Broadly following works shall be carried out under this Schedule 'B':

- a) *Construction of Portal P-1 for both UP and DN lines including protection arrangements (rock cutting, rock bolting, shotcreting etc.).*
- b) *Construction of drainage system at Palwal end approach of Portal P-1 of UP and DN lines for disposal of storm water coming out of the tunnel and from adjoining open area and integrating the drainage system with the drainage scheme of DFC.*
- c) *Construction of Abutment A-2 of proposed HORC viaduct for both UP and DN lines including bearing pedestal and seismic restrainers near Portal P-1.*
- d) Construction of bridges as per list given in **Annexure-F-3**.
- e) Any other item as directed by the Engineer related to the Works.

2.3 Scope under Schedule 'C' (Item Rate for miscellaneous works)

Under this Schedule, the Contractor is required to carry out works which are not covered in Schedule 'A' or Schedule 'B'.

- a) Diversion of all uncharted utilities, if required, as per approved plan.
- b) Any other activity as directed by the Engineer

2.4 REFERENCE TO THE STANDARD CODES OF PRACTICE

2.4.1 All Standards, Outline Construction Specifications (OCS)-Civil & BLT, Technical Specifications and Codes of Practice referred to shall be latest editions including all applicable official amendments and revisions. The Contractor shall make available at site all relevant Indian Standard Codes of practice, IRS, IS, IRC, UIC, as applicable.

2.4.2 Wherever Indian Standards do not cover some particular aspects of design/ construction, relevant International Standards will be referred to. The Contractor shall make available at site such standard codes of practice.

2.4.3 In case of discrepancy among Standard codes of practice and Section VII-6: Outline Construction Specifications (OCS)-Civil &BLT, the order of precedence shall be as given below:

- a) Outline Design Specifications-Civil &BLT
- b) Outline Construction Specifications-Civil &BLT
- c) Standard Codes of Practice.

In case of discrepancy among Standard Codes of Practice, the order of precedence will be

- (i) IRS,
- (ii) IS,
- (iii) IRC,
- (iv) other International codes
- d) Indian Railway Unified Standard Specifications,
- e) CPWD specifications,
- f) NBC 2016,
- g) MORTH Specification for Road & Bridges,

2.5 DIMENSIONS

As regards errors, omissions and discrepancies in Specifications and Drawings, relevant clause of Particular Specification will apply. The levels, measurements and other information concerning the existing site as shown on the conceptual / layout drawings are believed to be correct, but the Contractor should verify them for himself and also examine the nature of the ground as no claim or allowance whatsoever shall be entertained on account of any errors or omissions in the levels or strata turning out different from what is shown on the drawings.

2.6 INSPECTION

The Employer may appoint an independent agency to ensure the quality checking of design,

supply, fabrication, erection and construction of all works under Scope of the Works. *The payment to the independent agency shall be made by the Employer separately.* The Contractor shall ensure complete co-operation with the agency to perform their work satisfactorily. In addition, the Employer also reserves right to undertake quality check and inspection directly by itself.

2.7 ALIGNMENT OF TRACKS (TUNNEL, CUTTING & EMBANKMENT)

2.7.1 The alignment shall be as shown in the Tender drawings. The alignment has been developed by the Employer to meet operational and technical criteria. The Contractor is not required to evaluate the alignment for compliance with these criteria, but shall review it with respect to his own design and construction proposals and shall also satisfy himself that it suits to the available land width and there is no conflict with any existing and planned structures which are to be preserved.

2.7.2 The Contractor is permitted to propose *minor* deviations in alignment to suit his construction proposals, but he must demonstrate that any such deviations do not reduce the technical and operational performance. The Contractor needs to verify the contract boundaries while proposing any change in vertical and/or horizontal alignment but such deviations shall require prior approval of the Employer subject to following conditions: -

- a) There is no extra cost to the Employer
- b) Changes proposed are essentially required to suit the contractor's specific design
- c) There is no change at the contract boundaries or if there is any, the same is agreed by the Contractor of the adjoining section without any extra cost to the Employer.

2.7.3 *The ground levels shown in Conceptual Alignment Plan & L-Section tender drawings are based on preliminary survey. Detailed survey will have to be carried out by the Contractor for confirming and preparation of final Alignment Plan & L-Section. No cost implication shall be considered for any variation in the ground levels with respect to ground levels shown in conceptual Alignment Plan & L-Section tender drawings.*

2.8 CLEARANCES

2.8.1 The Permanent Works shall not infringe the Fixed Structure Gauge in tunnels as shown in *Tender* drawings and Indian Railway Schedule of Dimensions (IR SOD) at other places. Extra clearance shall be provided on curved alignment as per IR SOD.

2.8.2 The Permanent Works shall provide for the installation of operating equipment for the railway without infringement of the Fixed Structure Gauge and IR SOD.

2.9 DURABILITY AND MAINTENANCE

2.9.1 The Permanent Works shall be designed and constructed such that, if maintained reasonably and in accordance with the Contractor's statement of maintainability contained in the Contract, they shall endure in a serviceable condition throughout their minimum lives as described under Sub-Clause 2.3 of the Section VII-5: Outline Design Specifications (ODS)- Civil & BLT and in above mentioned paragraphs.

The Permanent Works shall be designed and constructed so as to minimise the cost of maintenance whilst not compromising the performance characteristics and ride quality of the railway.

2.10 OPERATIONAL REQUIREMENTS

2.10.1 The Permanent Works shall be designed to permit the railway to operate satisfactorily at a maximum design speed of 160 kmph where applicable.

2.10.2 During construction the Contractor shall be responsible for providing and maintaining adequate flood protection to the works.

2.11 ENVIRONMENTAL CONSIDERATIONS

All provisions and conditions contained in the Environmental, Social, Health and Safety (ESHS) Manual as per Appendix 13 of Section VII-9: Appendices, Part 2, Employer's Requirements shall be strictly complied with.

2.12 FUNCTIONAL REQUIREMENTS REGARDING INTERFACE WITH CONCERNED AUTHORITIES

Requests for temporary power supplies for the construction of the works must be submitted by the Contractor to the concerned authorities. Alternatively separate power supplies may be arranged by the Contractor subject to compliance with all necessary statutory requirements, especially pollution control.

2.13 TRAFFIC MANAGEMENT

The Contractor shall carry out the Works so as to minimise disruption to road and pedestrian traffic. The Contractor shall prepare his traffic management plan based on his proposed construction methodology in co-ordination with Engineer and in conjunction with the concerned road authority as per Appendix 10. He shall comply strictly with the approved plan during construction of his plan.

2.14 CRS INSPECTION

The Contractor shall note that the Commissioner for Railway Safety (CRS) will inspect the Works from time to time for the purpose of determining whether the HORC Project complies in terms of operational and infrastructural safety in accordance with the Laws of India. The

contractor shall note that CRS approval is mandatory for commissioning the system. Notwithstanding other provisions of the Contract, the Contractor shall ensure that the Works comply with the requirements of CRS. The Contractor shall make all necessary arrangements for assisting CRS in carrying out his inspection duties and also comply with his instructions regarding rectifying any defects and making good any deficiencies. Contractor shall prepare and make available all drawings, documents, sketches, photographs etc. as required for submission of application for inspection of CRS as instructed by the Engineer.

2.15 STANDARDS

- 2.15.1** Equipment, materials and systems shall be designed, manufactured and tested in accordance with the latest issue of National and/or International codes and standards. The Contractor shall submit copies to the Engineer of all codes and standards used for the work.
- 2.15.2** Reference to standards or to materials and equipment of a particular manufacturer shall be regarded as followed by the words “or equivalent”. The Contractor may propose alternative standard materials, or equipment that shall be equal to or better than those specified. If the Contractor for any reason proposes alternatives to or deviations from the specified standards, or desires to use materials or equipment not covered by the specified standards, the Contractor shall apply for the consent of the Engineer. The Contractor shall state the exact nature of the change, the reason for making the change and relevant specifications of the materials and equipment in the English language. The decision of the Engineer in the matter of quality will be final.

ANNEXURE-F-1

LIST OF MINOR BRIDGES UNDER SCHEDULE-A

S.NO.	Br. No.	*Chainage (M)	Type of Crossing	Type of Bridge	SPAN No. x L (in m) x H (in m)
1.	47	12208.018	Balancing Culvert	RCC Box	1x2.00x2.00
2.	48	12298.962	Drain+ Road	2 Cell RCC Box	1x4.0x5.0+ 1x5.0x5.0
3.	49	12341.836	Balancing Culvert	RCC Pipe	1x1.8
4.	50	12645.715	Balancing Culvert	RCC Box	1x2.00x2.00
5.	51	13114.998	Canal	RCC Box	1x3.00x3.00
6.	52	13903.112	<i>Balancing Culvert</i>	RCC Box	1x3.00x3.00
7.	54	14601.627	Canal	RCC Box	1x3.00x3.00
8.	55	14756.727	Road	RCC Box	1x5.00x5.00
9.	56	15100.163	Balancing Culvert	RCC Box	1x2.00x2.00
10.	57	15944	Road	RCC Box	1x5.00x5.00

*Main line Chainages start from Prithala station of HORC.

ANNEXURE-F-2

LIST OF MAJOR BRIDGES UNDER SCHEDULE-A

S.NO.	Br. No.	*Chainage (M)	Type of Crossing	Type of Bridge	SPAN No. x L (in m) H (in m)
1.	62	17500	Road	PSC U-Slab	1x12.20

*Main line Chainages start from Prithala station of HORC.

ANNEXURE-F-3

LIST OF BRIDGES UNDER SCHEDULE-B

S.NO.	Br. No.	*Chainage (M)	Type of Crossing	Type of Bridge	SPAN No. x L (in m) H (in m)
1.	53	14472.112	Stream	Composite Girder	2x24.40**
2.	58	16127	Canal	PSC U-Slab+ RCC box abutments	1x5x5.4+1x12.20 + 1x5.00x5.4
3.	59	16727	Road	PSC U-Slab	2x12.20
4.	60	16827	Road	RCC Box	2x7.00x5.60
5.	61	16917	Canal	PSC U-Slab + RCC box Abutments	1x5x5.4+ 1x12.20 +1x5x5.4

*Main line Chainages start from Prithala station of HORC.

**Fabrication & erection of composite steel superstructure is not in the scope of work.

ANNEXURE-F-4

APPROXIMATE LOCATIONS OF RETAINING WALL
Deleted

Tender No. HORC/HRIDC/C-4/2022

Attachment 3

to

Corrigendum No. 3

**Part 2, Section VII-4: Employer's
Requirements-Design (Civil & BLT)**

MINIMUM REQUIREMENT OF THE DDC'S ORGANIZATIONAL STRUCTURE /R1

MINIMUM REQUIREMENT OF THE DDC'S ORGANIZATIONAL STRUCTURE /R1

The DDC shall submit an Organisation Chart together with clear description of the responsibilities of each member within the overall works programme.

Sr.NO	Designation	Numbers	Experience
1	Team Leader	01	Graduate degree in Civil Engineering having experience not less than 15 years and would have handled minimum 02 projects involving design of tunnel by NATM as Team Leader.
2	Tunnel Design Expert (NATM)	02	Graduate degree in Civil Engineering <i>with total experience of 12 years</i> and minimum 6 years of relevant <i>experience in design of NATM tunnel.</i>
3	Tunnel Design Expert (Cut & Cover)	02	Graduate degree in Civil Engineering <i>with total experience of 12 years</i> and minimum 6 years of relevant experience in design of Cut & Cover tunnel .
4	Bridge Design Expert	01	Graduate degree in Civil Engineering <i>with total experience of 10 years</i> and minimum 5 years of relevant <i>experience in design of railway bridge involving deep foundation</i>

NOTES:

1. *The CVs of concerned personnel shall be submitted to the Engineer for approval. No person mentioned in table above shall be deployed in the project without Engineer's approval.*
2. *Relaxation in qualification / experience can be given by the Engineer in exceptional cases where candidates have got high level of professional competency. Decision of the Engineer in such cases shall be final and binding.*
3. The requirement given above is minimum. The Contractor shall be required to supplement the above mentioned design team as per requirement of the Works so as to adhere to the timelines given in Appendix-2- Contract Key Dates and Completion Date, Section VII-9: Appendices, Part 2- Employer's Requirements under the Contract.

Tender No. HORC/HRIDC/C-4/2022
Attachment 4
to
Corrigendum No. 3

**Part 2, Section VII-4: Employer's
Requirements-Construction (Civil & BLT)**

- 1. Attachment C-1/R2: Minimum Organisation Structure Required**
- 2. Attachment C-2/R2: Minimum Qualification & Experience of Project Personnel**
- 3. Attachment C-3/R2: Minimum Resources Required for the Project- Plant & Equipment**

ATTACHMENT - C-1/R2
MINIMUM ORGANISATION STRUCTURE REQUIRED

The figures indicated in Table 1 below are the minimum number of Project-Personnel required which are to be deployed as per the minimum level of supervision. The qualification/experience of such Project personnel is given under Attachment-C-2

TABLE-1 LIST OF MINIMUM ORGANISATION STRUCTURE REQUIRED

S. No.	Designation of Project Personnel	Minimum no. of Project-Personnel required	Penalty for Non-deployment per week or part thereof per person
1.	Contractor's Representative/ Project Manager	1	Rs1,00,000/-
2.	Senior Tunnel Expert (NATM)	4	Rs40,000/- for first 3 months and Rs. 80,000/- thereafter
3.	Tunnel Expert (NATM)	4	
4.	Ballast less Track Expert	1	-
5.	Planning Engineer	1	Rs40,000/- for first 3 months and Rs. 80,000/- thereafter
6.	Senior Quality Assurance/Quality Control Expert	2	Rs40,000/- for first 3 months and Rs. 80,000/- thereafter
7.	Quality Assurance/Quality Control Expert	2	
8.	Health & Safety Expert	4	Rs40,000/- for first 3 months and Rs. 80,000/- thereafter
9.	Surveyor	5	-
10.	Tunnel Expert (Cut & Cover)	2	Rs40,000/- for first 3 months and Rs. 80,000/- thereafter
11.	Bridge Expert	1	-
12.	Procurement Manager	1	-
13.	Senior Geologist	1	Rs40,000/- for first 3 months and Rs. 80,000/- thereafter
14.	Geologist	2	-
15.	Environmental Expert	1	-

S. No.	Designation of Project Personnel	Minimum no. of Project-Personnel required	Penalty for Non-deployment per week or part thereof per person
16.	Senior Geotechnical Engineer	1	Rs 40,000/- for first 3 months and Rs. 80,000/- thereafter
17.	Geotechnical Engineer	2	
18.	Blast Expert	1	
19.	Civil Engineer (Concrete Expert)	4	
20.	<i>Senior Electrical Engineer</i>	<i>1</i>	<i>Rs 40,000/- for first 3 months and Rs. 80,000/- thereafter</i>
21.	<i>Electrical Engineer</i>	<i>2</i>	
22.	<i>Senior Mechanical Engineer</i>	<i>1</i>	<i>Rs 40,000/- for first 3 months and Rs. 80,000/- thereafter</i>
23.	<i>Mechanical Engineer</i>	<i>2</i>	

NOTES:-

- i. The Contractor shall deploy resources as per the above-mentioned table. The Contractor shall also confirm to deploy manpower over and above the minimum numbers indicated above, if the work so requires.
- ii. The performance of project personnel deployed will be evaluated periodically by the Engineer during the contract period. In case the performance of any of the project personnel is not satisfactory, the Contractor shall replace them with good personnel immediately as per directions of the Engineer.
- iii. The personnel at Sr.No.1, must be deployed by Commencement Date. Personnel at Sr. No. 2, 5, 6, 8, 10, 13, 16, 20, & 22 in the above table must be deployed within 30 days of Commencement Date. Non adherence to these provisions shall attract penalty as indicated in the table above.
- iv. All *minimum resources indicated in the table above may not be required to be mobilized simultaneously for entire duration of the contract. The Contractor shall mobilize the resources as per the deployment programme approved by the Engineer.*
- v. In case of non-deployment of project personnel, the penalty shall be imposed as indicated above and deducted from Contractor's running / final bills. The decision of the Engineer in this regard shall be final and binding.
- vi. *The Contractor shall be required to supplement the above mentioned resources per requirement of the Works so as to adhere to the timelines given in Appendix-2- Contract Key Dates and Completion Date, Section VII-9: Appendices, Part 2- Employer's Requirements under the Contract.*

ATTACHMENT C-2/R2
MINIMUM QUALIFICATION & EXPERIENCE OF PROJECT PERSONNEL

S. No.	DESIGNATION	QUALIFICATION	EXPERIENCE LEVEL
1.	Contractor's Representative/ Project Manager	Graduate in Civil Engineering	Minimum total experience of 15 years out of which, minimum 5 years as In-charge in tunnel projects of Railway/ DFC/ Metro/ RRTS/ Highway /Expressways.
2.	Senior Tunnel Expert (NATM)	Graduate/Diploma in Civil Engineering	Minimum total experience of 10/12 years out of which minimum 05/08 years in relevant field in tunnel projects of Railway/ DFC/ Metro/ RRTS/ Highway /Expressways
3.	Tunnel Expert (NATM)	Graduate/Diploma in Civil Engineering	Minimum total experience of 8/10 years out of which minimum 03/05 years in relevant field in tunnel projects of Railway/ DFC/ Metro/ RRTS/ Highway /Expressways
4.	Ballastless Track Expert	Graduate/Diploma in Civil Engineering	Minimum total experience of 8/10 years out of which minimum 02/04 years in relevant field in ballastless track projects of Railway/ DFC/ Metro/ RRTS
5.	Planning Engineer	Graduate in Civil Engineering with Primavera software certification	Minimum total experience of 10 years out of which minimum 05 years in planning of Infrastructure projects.
6.	Senior Quality Assurance (QA) /Quality control (QC) Expert	Graduate/Diploma in Civil Engineering	Minimum total experience of 10/12 years out of which minimum 05/07 Yrs. In QA (Field) and at least one year as In-Charge in Infrastructure Project
7.	Quality Assurance (QA) /Quality control (QC) Expert	Graduate/Diploma in Civil Engineering	Minimum total experience of 08/10 years out of which minimum 03/05Yrs. in QA (Field) in Infrastructure Project
8.	Health & Safety Expert	Graduate/Diploma in Engineering/Science with one year full time Diploma in Industrial safety or equivalent	Minimum total experience of 06/08 years with relevant experience of 3 years in Infrastructure projects.
9.	Surveyor	Diploma in Civil Engineering / ITI	Minimum total Experience of 05/08 Years in Survey Work for linear Infrastructure project

S. No.	DESIGNATION	QUALIFICATION	EXPERIENCE LEVEL
10.	Tunnel Expert (Cut & Cover)	Graduate/Diploma in Civil Engineering	Minimum total experience of 8/10 years out of which minimum 03/05 years in relevant field in tunnel projects of Railway/ DFC/ Metro/ RRTS/ Highway /Expressways
11.	Bridge Expert	Graduate/Diploma in Civil Engineering	Minimum total experience of 08/10 years out of which minimum 03/05 years in relevant field in infrastructure projects involving bridges of Railway/ DFC/ Metro/ RRTS/ Highway /Expressways
12.	Procurement Manager	Graduate in Engineering / Diploma in procurement	Minimum total experience of 05/08 years in procurement in Infrastructure Project.
13.	Senior Geologist	Master's degree in Geology	Minimum total experience of 10 years out of which minimum 05 years in tunnel projects.
14.	Geologist	Master's degree in Geology	Minimum total experience of 05 years out of which minimum 03 years in tunnel projects.
15.	Environmental Expert	Graduate in Environmental Engineering/ Master's degree in Environmental Engineering/Environmental Science or equivalent	Minimum total experience of 06 years out of which 3 years of experience of working on environmental aspects in Infrastructure projects.
16.	<i>Senior Geotechnical Engineer</i>	<i>Graduate in Civil Engineering</i>	<i>Minimum total experience of 10 years out of which minimum 05 years in infrastructure projects.</i>
17.	<i>Geotechnical Engineer</i>	<i>Graduate/Diploma in Civil Engineering</i>	<i>Minimum total experience of 05/07 years out of which minimum 03/05 years in infrastructure projects.</i>
18.	Blast Expert	Graduate/Diploma in Engineering	Minimum Experience of 05/07 years in blasting
19.	Civil Engineer (Concrete Expert)	Graduate in Civil Engineering	Minimum total experience of 05 years out of which minimum 03 years in relevant field in Infrastructure projects.
20.	<i>Senior Electrical Engineer</i>	<i>Graduate in Electrical Engineering</i>	<i>Minimum total experience of 10 years out of which minimum 05 years in Electrical and E&M works (Experience in tunnel projects will be preferred)</i>
21.	<i>Electrical Engineer</i>	<i>Graduate/Diploma in Electrical Engineering</i>	<i>Minimum total experience of 05/07 years out of which minimum 03/05 years in Electrical and E&M works (Experience in tunnel projects will be preferred)</i>
22.	<i>Senior Mechanical Engineer</i>	<i>Graduate in Mechanical Engineering</i>	<i>Minimum total experience of 10 years out of which minimum 05 years in infrastructure projects.</i>

S. No.	DESIGNATION	QUALIFICATION	EXPERIENCELEVEL
23.	<i>Mechanical Engineer</i>	<i>Graduate/Diploma in Mechanical Engineering</i>	<i>Minimum total experience of 05 years out of which minimum 03 years in Infrastructure projects.</i>

Notes:

1. The CVs of concerned personnel shall be submitted to the Engineer for approval. No person mentioned in table above shall be deployed in the project without Engineer's approval.
2. Relaxation in qualification / experience can be given by the Engineer in exceptional cases where candidates have got high level of professional competency. Decision of the Engineer in such cases shall be final and binding.

ATTACHMENT C-3/R2

MINIMUM RESOURCES REQUIRED FOR THE PROJECT- PLANT & EQUIPMENT

The figures indicated below are the minimum number of equipment required.

S. No.	Types of Equipment Required for the Work	Minimum No. of Unit of Equipment Required for the Work
1.	Double Boomer	03
2.	Robotic Shotcrete Machine	07
3.	Concrete Batching Plant (each 60 cum/hr)	02
4.	Excavator (75 cum/hr)	07
5.	Grader	02
6.	Dozer (150 Cum/hr)	02
7.	Vibratory Roller (10 T)	02
8.	Pugmil/Crusher(200MT/hr)	01
9.	Concrete Boom Placer	02
10.	Stationary Concrete Pumps (36 cum/hr)	04
11.	Transit mixers	10
12.	Survey Instruments (Total Station)	04
13.	Lab Testing equipment-fully equipped for site tests.	As per Appendix 12 of Section VII-9: Appendices, Part 2- Employer's Requirements
14.	Digital Level (Leica, Sokia)	04
15.	Tunnel lining gantry of minimum length 15 m	04
16.	Loader (2 cum)	05
17.	Dumper (18 cum)	16
18.	Scissor platform (1ton)	03
19.	Diesel tanker (dispenser)	02
20.	Water tanker	02
21.	D G set (630kva)	06

S. No.	Types of Equipment Required for the Work	Minimum No. of Unit of Equipment Required for the Work
22.	<i>Blower fans (75Kw)</i>	06
23.	<i>JCB</i>	02
24.	<i>Grouting pumps (MAI & Uni pumps)</i>	04
25.	<i>Water pumps (10 HP)</i>	04
26.	<i>Tunnel profiler (Trimbel, S7/S9/S12, Leica TS16/MS60)</i>	02

Note:

- i. All plants and equipment need not be mobilized simultaneously. Plants and equipment as required as per the progress of the work shall be brought at site in advance as directed by the Engineer.

Tender No. HORC/HRIDC/C-4/2022
Attachment 5
to
Corrigendum No. 3

**Part 2, Section VII-5: Employer's Requirements -
Outline Design Specifications (ODS)-Civil & BLT
Sub-Clause 5.10- WATERPROOFING**

5.10 WATERPROOFING

The grade of concrete, treatment of construction joints, areas of slab pours and external protection shall be chosen such that the required standard of waterproofing can be achieved and maintained. Materials for expansion joints, caulking etc. shall have acceptable fire performance for use on an underground railway line.

- 1) Waterproofing of cut & cover tunnel shall be carried out by a manufacturer having minimum 10 years of experience in manufacturing waterproofing product of the type specified, able to provide test report showing compliance with the specifications, and able to provide on -site technical representation to advise on installation.
- 2) The installation shall be carried out either by the manufacturer or his approved applicator having experience of minimum 05 years in application of waterproofing products in underground structures. The waterproofing shall be carried out by manufacturer's applicators strictly in accordance with the recommendation of the manufacturer.
- 3) All components and elements, which are required to make the structures watertight, shall be demonstratable and proven to work together. There shall be a single source of responsibility and performance of the material and products. Specifically, material and water stops shall be manufactured out of virgin raw material and only form the same formulation of raw material. The manufacturer shall confirm full, demonstratable and proven compatibility of the entire waterproofing system in writing. The waterproofing system provided shall be installed without damage and protected against construction operations. The contractor shall carry out a trial application of the waterproofing and submit the report containing the details and method statement to obtain approval from the Engineer.
- 4) The waterproofing shall be provided on outside side of vertical walls and top slab.
- 5) Waterproofing scheme
 - i. Outside of vertical walls and top slab shall be provided with spray applied liquid coating of minimum thickness 2.0 mm as per IS 16471 (Type A).
 - ii. Construction joints in vertical walls shall be provided with PVC water stops as per IS 16471 (Type B).
 - iii. Use of waterproofing admixture to the concrete of slabs and walls of subway
- 6) Spray applied liquid coating on external side of vertical walls and top slab
 - i. System and properties of materials
Fully bonded spray-applied liquid polymer two component, solvent free, hybrid polyurea polyurethane/ polyurea/ polyurethane applied elastomeric seamless membrane of minimum 2 mm Dry Film Thickness (DFT) shall be used. DFT shall be achieved in minimum 2 coats (of two different contrasting colors), over and above one coat of a solvent free two component epoxy primer which shall be

compatible with the liquid polymer and from the same manufacturer. No sand broadcast layer is permitted in the system. The system must be such that it is thixotropic, can be applied by airless spray; as well as the same product shall be capable of being applied manually only for local detailing and patch repairs (maximum area 1 m²). The product shall be applied in accordance with the manufacturer's instructions.

- ii. The waterproofing membrane shall have following minimum properties:
- a. Tensile strength > 15MPa as per ASTM D 412.
 - b. % Elongation > 300% as per ASTM D 412.
 - c. Bond strength on concrete > 2 MPa as per ASTM D 7234.
 - d. Minimum crack bridging capability of over 2.0 mm.
 - e. Specific Gravity of 1.15 (+/-10%)
- iii. Code and standards for reference:

Code and standard Number	Code and Standard Title
ASTM D 412	Standard Test Methods for Vulcanized Rubber and Thermoplastic Elastomers - Tension
ASTM D 7234	Standard Test Methods for Pull-off Adhesion Strength of Coating on concrete Using portable Pull – off Adhesin Testers.

- iv. Inspection

The thickness of spray applied liquid coating waterproofing membrane shall be checked for every 20 m² area of water proofing. The thickness at the point of checking shall not be less than 2 mm.

7) Construction joints in vertical walls

- i. The contractor shall construct his concrete works so as to minimize the likelihood of water penetration.
- ii. Before placing new concrete against concrete that has already hardened, the face of the old concrete shall be treated in accordance with manufacturer's recommendation.
- iii. Inside rendering shall not be accepted as a method of making joints watertight.
- iv. Water stops shall be of PVC strips. The water stops shall be installed so that they are securely held in their correct positions whilst the concrete is being placed. No holes shall be made through any water stop except were provided for by the manufacturer. Water stops shall be provided as per manufacturer recommendations. The contractor shall submit the method statement for providing water stops to the Engineer for approval.

8) Use of waterproofing admixtures in concrete of slabs and vertical walls of subway

Waterproofing admixtures shall be used in conjunction with other waterproofing components supplied by the same manufacturer, for example, water stops, achieve watertight structures.

9) Surface preparation

Waterproofing work shall commence only after obtaining approval from the Engineer. Application of waterproofing system shall only commence upon the completion of curing of concrete. All cracks on the exposed concrete surfaces of external structural members shall be effectively sealed before applying any waterproofing system. The Contractor shall ensure that surfaces to which waterproofing is to be applied, shall be clean, dust-free and dry and shall be prepared fully in accordance with the manufacturer's recommendation. The waterproofing shall be carried out by the manufacturer's applicators strictly in accordance with the recommendations of the manufacturer and with accepted best practice in the trade.

Tender No. HORC/HRIDC/C-4/2022

Attachment 6 to Corrigendum No. 3

Section VII: Employer's Requirements

Section VII-6: Outline Construction Specifications (OCS)- Civil &BLT/R1

Chapter 1	3
GENERAL-CIVIL	3
CHAPTER-2.....	32
SITE INSTALLATIONS AND SERVICES	32
CHAPTER -3.....	50
SURVEYING	50
CHAPTER -4.....	58
DEWATERING, DRAINAGE, PUMPING AND WATERPROOFING.....	58
CHAPTER -5.....	71
DEWATERING OF SURFACE CONSTRUCTION SITES	71
CHAPTER -6.....	74
EXPLOSIVE AND BLASTING	74
CHAPTER 7: INSTRUMENTATION.....	92
ANNEXURE TO CHAPTER 7 MONITORING RECORDING AND THE CONTROL PROCESS OF UNDERGROUND WORKS	108
CHAPTER -8.....	114
UNDERGROUND EXCAVATION	114
CHAPTER - 9.....	138
STRUCTURAL STEEL SUPPORT	138
CHAPTER -10.....	142
ROCK BOLTS, WIREMESH, FOREPOLING AND PIPE ROOFING.....	142
CHAPTER -11.....	152
SHOTCRETE	152
CHAPTER -12.....	168
DRILLING AND GROUTING.....	168
CHAPTER 13.....	186
EARTHWORK IN FORMATION.....	186
CHAPTER 14.....	188
BRIDGES	188
CHAPTER 15.....	215
BALLASTLESS TRACK	215
CHAPTER 16.....	221
OPEN EXCAVATION	221

ANNEXURE OCS-1	232
PLAIN AND REINFORCED CEMENT CONCRETE	232
ANNEXURE OCS-2	267
REINFORCEMENT STEEL	267
ANNEXURE OCS-3	274
FABRICATION AND ERECTION OF STEEL BRIDGE GIRDER	274
ANNEXURE OCS-4	284
PRESTRESSING.....	284

Chapter 1

GENERAL-CIVIL

1.1 GENERAL:

- 1.1.1** These Specifications contained herein shall be read in conjunction with other tender documents.
- 1.1.2** All Materials, works and construction operations for civil works shall conform to the following manuals:
- a) Indian Railways Permanent Way Manual
 - b) Indian Railway Bridge Manual
 - c) Indian Railway Works Manual
 - d) Indian Railway Schedule of Dimensions
 - e) Indian Railways Unified Standard Specification (Formation Works, Bridge Works and P.Way Works), *North Western Railway Unified Standard Schedule of Rates 2019*.
 - f) The relevant IRS Specifications referred to in the above documents listed at (a), (b), (c), (d) & (e)
 - g) CPWD Specifications, Vol 1&2 – 2019 for building works *and Delhi Schedule of Rates (DSR) 2021*
 - h) In case of any contradiction in the various codal provisions, the order of precedence shall be as follows:-
 - i. IRS Codal provisions
 - ii. IRC Codal provisions
 - iii. IS(BIS) Codal provisions
- 1.1.3** The Work shall be carried out in accordance with the "Good for Construction" drawings and designs as would be issued to the Contractor by the Engineer duly signed and stamped by him. The Contractor shall not take cognizance of any drawings, designs, specifications, etc. not bearing Engineer's signature and stamp. Similarly, the Contractor shall not take cognizance of instructions given by any other Authority except the instructions given by the Engineer in writing.
- 1.1.4** The work shall be executed and measured as per metric units given in the Schedule of Quantities, drawings etc. (FPS units where indicated are for guidance only).
- 1.1.5** Absence of terms such as providing, supplying, laying, installing, fixing etc in the descriptions does not even remotely suggest that the Contractor is absolved of such providing, supplying etc. unless an explicit stipulation is made in this contract. The Employer shall bear no costs of materials, labour, equipment, duties, taxes, royalties etc.
- 1.1.6** The specifications may have been divided into different sections / sub-heads for

convenience only. They do not restrict any cross-references. The Contractor shall take into account inter-relations between various parts of works/trades. No claim shall be entertained on the basis of compartmental interpretations.

1.1.7 Reference to the Standard Codes of Practice:

- a) The Contractor shall make available at site all relevant Codes of practice as applicable.

Legends	Definition
IRS	Indian Railway Standards
IR specifications	Indian Railways Unified Standard Specification (Formation Works, Bridge Works and P.Way Works)
IS	Indian Standards
IRC	Indian Road Congress
CPWD	Central Public Works Department
RDSO	Research Designs and Standards Organisation
UIC	International Union of Railways (UIC, French: Union internationale des chemins de fer)
MORTH	Ministry of Road Transport and Highways
EN	European Standard
ISO	International Organization for Standardization
ASTM	American Section of the International Association for Testing and Materials
BS	British Standard

- 1.1.8** Alternative or additional codes and standards proposed by the Contractor shall be internationally recognized codes and shall be equivalent to or better than, Indian Standards issued by the Bureau of Indian Standards or any other Indian professional body or organization, subject to being, in the opinion of the Employer's Representative, suitable for incorporation or reference into the specifications.

1.1.9 Contractor to Provide:

The Contractor shall provide and maintain at site throughout the period of works the following at his own cost and without extra charge, except for the items specified in the Bill of Quantities the cost being held to be included in the Contract

Rates:

- a) General works such as setting out, site clearance before setting out and on completion of works. All weather approach roads to the site office should also be constructed and maintained in good condition.
- b) All labour, materials, plant, equipment and temporary works, Overhead charges as well as general liabilities, obligations, insurance and risks arising out of GCC, required to complete and maintain the works to the satisfaction of the Engineer.
- c) Adequate lighting for night work, and also whenever and wherever required by the Engineer.
- d) Temporary fences, barricades, guards, lights and protective work necessary for protection of workmen, supervisors, engineers, General public and any other persons permitted access to the site. Contractor shall provide proper signages as directed.
- e) All fences, barricade shall be painted with colour shades as specified by the Engineer. The barricading should be of adequate height to ensure visual obstruction of work from public view.
- f) All equipment, instruments, labour and materials required by the Engineer for checking alignment, levels, slopes and evenness of surfaces measurements and quality etc.
- g) Design mixes and testing them as per relevant clauses of specifications giving proportion of ingredients, sources of aggregates and binder along with accompanying trial mixes. Test results to be submitted to the Engineer for his approval before adoption on works.
- h) Cost of Preparation and compliance with provision of a quality assurance control program.
- i) Cost of safeguarding the environment.
- j) A testing laboratory as specified *in Appendix 12, Section VII-9: Appendices, Part 2 Employer's Requirements shall be set up by the Contractor.*

1.1.10 Quality Assurance & Quality Control:

- a) The work shall conform to high standards of design and workmanship, shall be structurally sound and aesthetically pleasing. The Contractor shall conform to the Quality standards prescribed, which shall form the backbone for the Quality Assurance and Quality Control system.
- b) At the site, the Contractor shall arrange the materials, their stacking/storage in appropriate manner to ensure the quality. The Contractor shall provide all the necessary equipment and qualified manpower to test the quality of materials, assemblies etc., as directed by the Engineer. The tests shall be conducted at specified intervals and the results of tests properly documented. In addition, the Contractor shall keep appropriate tools and equipment for checking

alignments, levels, slopes, and evenness of the surfaces.

- c) The Engineer shall be free to carry out such tests as may be decided by him at his sole discretion, from time to time, in addition to those specified in this document. The Contractor may provide the samples and labour for collecting the samples. Nothing extra shall be payable to the Contractor for samples or for the collection of the samples.
 - i. The test shall be conducted at the Site laboratory that may be established by the Contractor or at any other Standard Laboratory selected by the Engineer.
 - ii. The Contractor shall transport the samples to the laboratory for which nothing extra shall be payable. In the event of the Contractor failing to arrange transportation of the samples in proper time the Engineer shall have them transported and recover two times the actual cost from the Contractor's bills.
 - iii. All testing shall be performed in the presence of Engineer. Testing may be witnessed by the Contractor or his authorised representative if permitted by the Test House. Whether witnessed by the Contractor or not, the test results shall be binding on the Contractor.
- d) The Engineer shall have the right at all times to inspect all operations including the sources of materials, procurement, layout and storage of materials, all equipment including the concrete batching and mixing equipment, and the quality control system. Such an inspection shall be arranged, and the Engineer's approval obtained prior to starting of the particular item of work. This shall, however, not relieve the Contractor of his responsibilities. All materials which do not conform to these specifications shall be rejected and shall be removed from the site immediately. The Engineer shall have the powers to cause the Contractors to purchase and use materials from any particular source, as May in the Engineer's opinion be necessary for the proper execution of work.

1.1.11 Training

The Contractor shall arrange the following trainings for all his concerned persons and 25 persons of the Engineer and the Employer together:

- a) 2 days training for Tunnelling by NATM and Cut & Cover method.
- b) 3 days training for concrete, testing, scaffolding and formwork including one day for practical demonstration at site
- c) The Contractor shall bear all the expenditure for training including boarding, lodging, airfare, transport, and remuneration of trainers. Training place shall be provided by the Employer free of cost. However, the Contractor shall bear the expenditure for refreshments and meals for all the participants during the training period. The syllabus of training and the

names of the trainers shall be submitted to the Engineer for approval. Training shall be imparted only by those trainers who are approved by the Engineer.

1.1.12 Dimensions:

- a) Figured dimensions on drawings shall only be followed and drawings to a large scale shall take precedence over those to a smaller scale. Special dimensions or directions in the specifications shall supersede all others. All dimensions shall be checked on site prior to execution.
- b) The dimensions where stated do not allow for waste, laps, joints, etc. but the Contractor shall provide at his own cost sufficient labour and materials to cover such waste, laps, joints, etc.
- c) The levels, measurements and other information concerning the existing site as shown on the drawings are believed to be correct, but the Contractor should verify them for himself and also examine the nature of the ground as no claim or allowance whatsoever will be entertained on account of any errors or omissions in the levels or the description of the ground levels or strata turning out different from what was expected or shown on the drawings.

1.1.13 Setting out of Works:

The Contractor shall set out the Works indicated in the Contract. The Contractor shall provide suitable stones with flat tops and build the same in concrete for temporary benchmarks. All the pegs for setting out the Works and fixing the levels required for the execution thereof shall, if desired by the Engineer, likewise be built in masonry at such places and in such a manner as the Engineer may direct. The Contractor shall carefully protect and preserve all benchmarks and other marks used in setting out the works. The Contractor will make overall layout of complete work and get it checked from engineer. The cost of all operations of setting out including construction of benchmarks is deemed to be included in the quoted rates.

- a) All the survey work except leveling work shall be carried out using total stations with one second accuracy. The leveling work shall be carried out using Auto level.
- b) The triangulations point given by concerned organization before start of work shall be maintained during execution and handed over back to concerned organization after completion of work.

1.1.14 Materials:

- a) Source of Materials:

It shall be the responsibility of the Contractor to procure all the materials required for construction and completion of the contract. The Contractor shall indicate in writing the source of materials well in advance to the Engineer, after the award of the work and before commencing the work. If

the material from any source is found to be unacceptable at any time, it shall be rejected by the Engineer and the Contractor shall forthwith remove the material immediately from the site as directed by the Engineer.

b) Quality:

All materials used in the works shall be of the best quality of their respective kinds as specified herein, obtained from sources and suppliers approved by the Engineer and shall comply strictly with the tests prescribed hereafter, or where tests are not laid down in the specifications, with the requirements of the latest issues of the relevant Indian Standards.

c) Sampling and Testing:

All materials used in the works shall be subjected to inspection and test in addition to test certificates. Samples of all materials proposed to be employed in the permanent works shall be submitted to the Engineer at least 45 days in advance for approval before they are brought to the site.

Samples provided to the Engineer for their retention are to be labeled in boxes suitable for storage. Materials or workmanship not corresponding in character and quality with approved samples will be rejected by the Engineer.

Samples required for approval and testing must be supplied sufficiently in advance if required quality and number to allow for testing and approval, due allowance being made for the fact that if the first samples are rejected further samples may be required. Delay to the works arising from the late submission of samples will not be acceptable as a reason for delay in completion of the works.

Materials shall be tested before leaving the manufacturer's premises, quarry or resource, wherever possible. Materials shall also be tested on the site and they may be rejected if not found suitable or in accordance with the specification, notwithstanding the results of the tests at the manufacturer's works or elsewhere or test certificates or any approval given earlier.

The Contractor will bear all expenses for sampling and testing, whether at the manufacturer's premises at source, at site or at any testing laboratory or institution as directed by the Engineer. No extra payment shall be made on this account.

d) Dispatch of materials:

Materials shall not be dispatched from the manufacturer's works to the site without written authority from the Engineer.

e) Test certificates:

All manufacturer's certificates of test, proof sheets, etc. showing that the materials have been tested in accordance with the requirement of this specification and of the appropriate Indian Standard, are to be supplied free

of charge on request to the Engineer.

f) Rejection:

Any materials that have not been found to conform to the specifications will be rejected forthwith and shall be removed from the site by the Contractor at his own cost within two weeks or as instructed by the Engineer.

g) The Engineer shall have power to cause the Contractors to purchase and use such materials from any particular source, as may in his opinion be necessary for the proper execution of the work.

1.1.15 Storing of Materials at site:

- a) All materials used in the works shall be stored on racks, supports, in bins, under cover etc. as appropriate to prevent deterioration or damage from any cause whatsoever to the entire satisfaction of the Engineer.
- b) The storage of materials shall be in accordance with IS 4082 “Recommendation on stacking and storage of construction materials on site” and as per IS 7969 “Safety code for handling and storage of building materials”.
- c) The materials shall be stored in a proper manner at places at site approved by the Engineer. Should the place where material is stored by the Contractor be required by the Employer for any other purpose, the Contractor shall forthwith remove the material from that place at his own cost and clear the place for the use of the Employer.

1.1.16 Water:

a) Water from approved source:

Potable water only shall be used for the works. Contractor shall have his own source of water duly approved by Engineer. The water shall be free from any deleterious matter in solution or in suspension and be obtained from an approved source. The quality of water shall conform to IS 456.

b) Storage:

The Contractor shall make his own arrangements for storing water, if necessary, in drums or tanks or cisterns, to the approval of the Engineer. Care shall be exercised to see that water is not contaminated in any way.

c) Testing:

Before starting any concreting work and wherever the source of water changes, the water shall be tested for its chemical and other impurities to ascertain its suitability for use in concrete for approval of the Engineer. No water shall be used until tested and found satisfactory. Cost of all such Tests shall be borne by the Contractor.

1.1.17 Workmanship:

- a) All works shall be true to level, plumb and square and the corners, edges and arises in all cases shall be unbroken and neat.

Any work not to the satisfaction of the Engineer or his representative will be rejected and the same shall be rectified or removed and replaced with work of the required standard of workmanship at no extra cost.

1.1.18 Load Testing on Completed Structures

- a) Load Testing of superstructure, in case of major bridges with OWG/ composite girders/ PSC girders and minor bridges with skew shall be done by the Contractor as per the directions of the Engineer. Cost of span load test is included in Schedule-C.
- b) During the period of construction or within the defect liability period the Engineer may at his discretion order the load testing of any completed structure or any part thereof if he has reasonable doubts about the adequacy of the strength of such structure for any of the following reasons:
- i. Results of compressive strength on concrete test cubes falling below the specified strength.
 - ii. Premature removal of formwork.
 - iii. Inadequate curing of concrete.
 - iv. *Overloading* during the construction of the structure or part thereof.
 - v. Carrying out concreting of any portion without prior approval of the Engineer.
 - vi. Honey combed or damaged concrete which in the opinion of the Engineer
 - vii. is particularly weak and will affect the stability of the structure to carry the design load, more so in important or critical areas of the structure.
 - viii. Loss of camber in OWG beyond permissible range as specified by Railway Board/RDSO.
 - ix. Any other circumstances attributable to alleged negligence of the Contractor which in the opinion of the Engineer may result in the structure or any part thereof being of less than the expected strength.
- c) All the loading tests shall be carried out by the Contractor strictly in accordance with the instructions of the Engineer, as per IRS:CBC and IRC:SP-51. Such tests shall be carried out only after expiry of minimum 28 days or such longer period as directed by the Engineer.
- d) The structure shall be subjected to the load as approved for SLS condition in the design. This load shall be maintained for a period of 24 hours before removal. Incremental loading shall be done in accordance with IRC:SP-51, unless otherwise directed by the Engineer.
- e) In case the recovery of the structure is not as per codal provisions, the

structure shall be considered to have failed to pass the test and shall be deemed to be unacceptable.

- f) In such cases the portion of the work concerned shall be taken down or cut out and reconstructed to comply with the specifications. Other remedial measures may be taken to make the structure secure at the discretion of the Engineer. However, such remedial measures shall be carried out to the complete satisfaction of the Engineer. Again, Load test shall be conducted as per codal provisions.
- g) All costs involved in carrying out the tests (except integrity test for piles) and other incidental expense thereto shall be borne by the Contractor regardless of the result of the tests. The Contractor shall take down or cut out and reconstruct the defective work or shall make the remedial measures instructed at his own cost.
- h) If the load testing is instructed on any ground other than mentioned in (i) to (ix) of Cl. 1.1.18(b), the cost of the same shall be reimbursed to the Contractor, if the result of the test are found to be satisfactory.
- i) In addition to the load tests mentioned in these document, non-destructive test methods such as core test and ultrasonic pulse velocity test shall be carried out by the Contractor at his own expense if so desired by the Engineer. Such tests shall be carried out by an agency approved by the Engineer and shall be done using only recommended testing equipment. The acceptance criteria for these tests shall be as per provisions in the relevant Indian/International standards and as approved by the Engineer.

1.2 STRUCTURAL WORK:

- 1.2.1** Unless specified, only controlled concrete with design mix and weigh batching is to be used for the work.
- 1.2.2** Minimum cement content specified in the codal specifications is purely from durability point of view. Larger content of cement shall have to be provided if demanded by mix design.
- 1.2.3** Provision of cement slurry to create bond between plain / reinforced concrete surface and subsequent applied finishes shall not be paid extra.
- 1.2.4** Mix design using smaller aggregates of 10mm down shall also be done in advance for the use in the junction having congested reinforcement.
- 1.2.5** Procedure of mixing the admixtures shall be strictly as per the manufacturer's recommendations if not otherwise directed by the Engineer.
- 1.2.6** All the water tanks and other liquid retaining concrete structures shall undergo hydro-testing.
- 1.2.7** Special benches shall be provided at site for stacking reinforcement bars of different sizes.
- 1.2.8** Formwork for beams of RCC areas shall be designed in such a way that the

formwork of the adjacent slabs can be removed without disturbing the props / supports of the beams.

1.2.9 *Deleted.*

1.2.10 Formwork is required for full height at all locations. Special precautions for such tall formwork shall be taken to ensure its safety. Extra costs for such formwork shall be deemed to have been included in the price quoted against relevant items.

1.2.11 In the mobilization period, the Contractor shall carry out expeditiously and without delay the following works:

- i. Material testing and mix designs of concrete as contemplated in the specifications.
- ii. Setting up of full-fledged site laboratory as per the requirements of these specifications.
- iii. Any other pre-requisite items required for final execution.
- iv. Site office for the use of the Engineer staff.
- v. Casting yard with full facilities.

1.2.12 *Deleted*

1.2.13 **Fabrication yard to have following minimum facilities:**

- i. Fabrication beds as required.
- ii. All handling facilities.
- iii. Stacking arrangements for precast elements.
- iv. Storing of materials.
- v. Proper drainage and approach roads.

1.3 **SUPPLY OF PROGRES PHOTOGRAPHS AND ALBUMS (DIGITAL):**

The work covers the supply of digital photographs to serve as a permanent record of various stages/facets of work needed for authentic documentation as approved by the Engineer.

The photographs shall be of acceptable quality and they shall be taken by a professionally competent photographer with a camera having the facility to record the date of the photographs taken in the soft copy. Each photograph in the album shall be suitably captioned and dated.

The photographs and materials shall form a part of the records of concerned organization and the same cannot be supplied to anybody else or published without the written permission of concerned organization.

1.4 **SUPPLY OF VIDEO CDs:**

The work consists of taking video films of important activities of the works as directed by the Engineer during the currency of the Project and editing them to a video film of playing time not less than 60 minutes. It shall contain narration of the

activities in English by a competent narrator. The edition of the film and script of the narration shall be approved by the Engineer.

Drone videography of the whole package for inspection and monitoring of structures shall be done by the Contractor once in a month.

The record of progress (photographs and videos) shall be submitted to the engineer on a monthly basis or as directed by engineer.

1.5 SURVEY WORK:

The said work involves at the very start of work taking-over of reference point from the Engineer, establishment of control points, triangulation points, bench marks, grid layout for all the piers and other structures maintaining horizontal and vertical control within the permissible limits, incorporating changes (if any), submission of full data in the tabulation form and survey drawings including setting and layout of various works during the progress of work and matching of the station area track alignment with the alignment of the approaches at station ends and incorporating the changes (if any).

1.6 BARRICADING AND PROJECT INFORMATION SIGNBOARDS

The Contractor shall provide barricading to demarcate Works Areas from the public area. All barricading shall be done at own cost by the Contractor. The detailed scope of work is as follows:

- i. Providing and installing the barricade of the design and type as shown in the Tender Drawings and as per the approved plan firmly to the ground and maintaining it during the progress of work.
- ii. Painting of the barricades shall be carried out to the design and colours as directed by the Engineer and the Contractor shall carry out re-painting of the entire barricades on a bi-annual basis.
- iii. Providing lighting on the periphery of barricades for direction illumination.
- iv. Project information signboards at each works area and Site Office shall be erected, not later than four (4) weeks, or such other period as the Engineer has given his consent, after the Date of Commencement of the Works. The types, sizes and locations of project signboards shall be agreed with the Engineer before manufacture and erection. Other advertising signs shall not be erected on the Site.
- v. The consent of the Engineer shall be obtained before barricading and hoardings signboards are removed.
- vi. Barricades and signboards shall be maintained in clean and good order by the Contractor until the completion of the Works. All the barricading and signboards etc. shall be mopped minimum once in a week and washed monthly.
- vii. Damaged/worn-out barricades shall be replaced by the Contractor within 24 hours. Engineer's decision regarding the need for replacement shall be final and binding.

If no action is taken by the Contractor, the cost of any repairs will be deducted by the Engineer from any payment due to the Contractor.

- viii. Dismantling of barricading and other temporary installations from the site and cleaning the site as per direction of Engineer upon completion and acceptance of work.

1.7 FINISHING WORK:

- 1.7.1** The Contractor shall incorporate seismic considerations of anchoring and isolation in the design and detailing of the finishes as directed by the Engineer. The element to be anchored shall have its motion suitably restrained whilst at the same time it shall be suitably isolated so as not to be affected by the deformations/ vibrations of the building during Construction.

1.7.2 Sub-Contractor:

Works as listed below and those dealing with proprietary materials/ products may be carried out by the Contractor through the Sub-Contractors as may be approved by the Engineer in writing. The Sub-Contractors must be firms of repute and long standing, having adequate experience and complete facilities to carry out all items of work required for completion as per Specifications and expected quality to the satisfaction of the Engineer. The Sub-Contractor must also have personnel experienced in preparing shop drawings. All such works, not limited to the following, shall be carried out under the direct supervision of the manufacturers of the proprietary materials/ products or their trained and accredited licensee.

- i. Bearings
- ii. Fabrication, assembly and launching of steel OWG

1.7.3 Responsibility for Shop drawings, Samples and Mock-ups:

Approval of shop drawings, samples and mock-ups for the various components shall not absolve the Contractor of his responsibility of completing the work to the specifications, standards, tests for performance and guarantees given in these documents and to a quality of finish as desired by the Engineer.

1.7.4 Cleaning:

Surfaces on which finishes are to be provided shall be cleaned with water jets or oil free compressed air or power tools with wire brushes and detergents all as approved by the Engineer.

1.7.5 Applicable Codes, Standards & Publications for Structural & Architectural Work:

The more important Codes, Standards and Publications to Contract are listed here under.

Any other code/publication, if found necessary by the engineer, may be referred to for such works. The latest revision along with all corrections slip & amendments shall only be followed

Sr. No.	Code No.	Code Name
General		
1.	IS: 875	Code of Practice for design loads (other than earthquake) for buildings and structures
2.	IS: 122 (part 4)	Methods of measurement of buildings and Civil engineering works-Stone masonry
3.	IS:1237	Specification for cement concrete flooring tiles
4.	IS: 1322	Bitumen felts for water proofing and damp-proofing
5.	IS: 1893	Criteria for earthquake resistant design of structures
6.	IS: 2185 (Part 1)	Concrete masonry units: Hollow and solid concrete
7.	IS: 2185 (Part 2)	Concrete masonry units: Hollow and solid light weight
8.	IS: 2185 (Part 3)	Concrete masonry units: Autoclaved cellular aerated concrete blocks
9.	IS: 2572	Code of Practice for construction of hollow concrete block Masonry
10.	IS: 3414	Code of practice for design and installation of joints in Buildings
11.	IS: 3462	Specification for unbacked flexible PVC flooring
12.	IS: 5318	Code of practice for laying of flexible PVC sheet and tile Flooring
13.	IS: 6408 (Parts 1,2)	Recommendations for modular co-ordination in building Industry-tolerances
14.	IS: 8183	Bonded mineral wool
15.	IS:10958	General check list of functions of joints in building
16.	IS:11817	Classification of joints in buildings for accommodation of dimensional deviations during

Sr. No.	Code No.	Code Name
		construction
17.	IS:11818	Method of test for laboratory determination of air permeability of joints in buildings
18.	IS:12440	Precast concrete stone masonry blocks
19.	CPWD	Specifications with up-to-date correction slips
20.	BS:476 (Part 7)	Method for classification of the surface spread of flame of Products
21.	BS:476 (Part 20)	Method of determination of the fire resistance of elements of construction (general principles)
22.	BS:476 (Part 22)	Methods for determination of the fire resistance of non-load bearing elements of construction
23.	BS: 1245	Specification for metal door frames (steel)
24.	BS: 3261	Specification for unbacked flexible PVC flooring
25.	BS:3261: Part 1	Homogeneous flooring
26.	BS:5215	Specification for one-part gun grade polysulphide-based Sealants
27.	BS:5606	Guide to accuracy in building
28.	BS:5725 (Part 1)	Specification for panic bolts and panic latches mechanically operated by a horizontal push-bar
29.	BS:6093	Code of practice for the design of joints and jointing in building construction
30.	BS:8200	Code of practice for the design of non-load bearing external vertical enclosure of building
31.	ASTM C 332	Specification for light weight aggregate for insulating Concrete
32.	ASTM C 635	Specification for the manufacture, performance and testing of metal suspension systems for acoustical

Sr. No.	Code No.	Code Name
		tile and lay-in panel ceilings
33.	SP 7	National Building Code of India
34.	SP 23 (S&T)	Hand Book on Concrete Mixes
Bitumen		
35.	IS:702	Industrial Bitumen
36.	IS:3384	Specification for bitumen primer for use in waterproofing and damp-proofing
Building Construction Practices		
37.	IS: 1838 Parts I and II.	Specifications for preformed fillers for expansion joint in concrete pavements and structures
38.	IS: 1946	Code of Practice for use of fixing devices in walls, ceilings, and floors of solid construction.
39.	IS: 3414	Code of Practice for design and installation of joints in buildings.
40.	IS: 6509	Code of Practice for installation of joints in concrete pavements.
41.	IS: 11134	Code of Practice for setting out of buildings.
42.	IS: 11433	Parts I and II. Specifications for one part Gun grade polysulphide based joint sealant
43.	IS: 12200	Code of Practice for provision of water stops at transverse construction joints in masonry and concrete dams
Cement		
44.	IS:269	33 grade ordinary Portland cement
45.	IS: 455	Portland Slag Cement
46.	IS: 650	Specification for standard sand for testing cement

Sr. No.	Code No.	Code Name
47.	IS: 1489 (Part 1)	Portland pozzolana cement: Fly ash based
48.	IS: 1489 (Part 2)	Portland pozzolana cement: Calcined clay based
49.	IS: 3535	Method of Sampling Hydraulic Cements
50.	IS: 4031	(Parts 1 to 13) Methods of physical tests for hydraulic cement
51.	IS:4032	Methods of chemical analysis of hydraulic cement
52.	IS: 6925	Methods of test for determination of water-soluble chlorides in concrete admixtures
53.	IS:8042	White Portland Cement
54.	IS: 8112	Specification for 43 grade ordinary Portland cement
55.	IS:12269	Specification for 53 grade ordinary Portland cement
56.	IS: 12330	Specification for sulphate resistant Portland cement
57.	IRS: T40	Indian Railways standard specification for special grade cement for use in concrete sleepers
Concrete		
58.	IS:456	Code of practice for plain and reinforced concrete
59.	IS: 457	Code of practice for general construction of plain and reinforced concrete for dams and other massive structures
60.	IS: 460 (Part I TO III)	Specification for Test Sieves
61.	IS: 516	Methods of tests for strength of concrete
62.	IS: 1199	Methods of sampling & analysis of concrete
63.	IS: 1200	Methods of measurement of building and civil engineering
64.	IS: 1343	Code of practice for prestressed concrete

Sr. No.	Code No.	Code Name
65.	IS: 1607	Methods of Test Sieving
66.	IS:2386	Parts I-VIII. Methods of tests for aggregates for concrete.
67.	IS:2430	Methods of Sampling of Aggregates of Concrete
68.	IS:2438	Specification for roller pan mixer
69.	IS:2514	Specification for concrete vibrating tables
70.	IS:2571	Code of practice for laying in-situ cement concrete Flooring
71.	IS:2645	Specifications for integral cement water proofing Compounds
72.	IS:2722	Specifications for portable swing batchers for concrete (double bucket type)
73.	IS:2770	Methods of testing bond in reinforced concrete part I pull out test
74.	IS:3025	Methods of sampling and test (physical and chemical) for water & waste water
75.	IS:3370	Code of practice for concrete structures for storage of Liquids
76.	IS:3935.	Code of practice for composite construction
77.	IS:4326	Code of practice for earthquake resistant construction of Building
78.	IS:6925.	Methods of test for determination of water soluble chlorides in concrete Admixtures
79.	IS:7242	Specifications for concrete spreaders
80.	IS:7251	Specifications for concrete finishers
81.	IS:7861	Parts I & II. Code of practice for extreme weather concreting

Sr. No.	Code No.	Code Name
82.	IS:7969	Safety code for handling and storage of building materials
83.	IS:8989	Safety code for erection of concrete framed structures
84.	IS:8142	Methods of test for determining setting time of concrete by penetration resistance
85.	IS: 9103	Specification for admixtures for concrete
86.	IS: 9013	Method of making, curing and determining compressive strengths of accelerated cured concrete test specimens
87.	IS: 9284	Method of test for abrasion resistance of concrete
88.	IS:10262	Recommended guidelines for concrete mix design
89.	IS: 4926	Code of Practice ready mixed concrete needs to be included in list
90.	MORTH	Specifications for Road and Bridge Works, Ministry of Road Transport and Highways (Roads Wing)
91.	SP 34	Handbook on Concrete Reinforcement and Detailing
92.	IRS	Concrete Bridge Code
93.	IRC 112	Code of Practice for Concrete Road Bridge
94.	IRC 83 (Part 4)	Standard Specifications and code of practice for road bridges Section IX Bearings (Spherical & Cylindrical)
95.	ASTM-C-94	Ready Mix Concrete
Construction Plant and Machinery		
96.	IS: 1791	Specification for batch type concrete mixers
97.	IS: 2505	General requirements for concrete vibrators: Immersion type.

Sr. No.	Code No.	Code Name
98.	IS: 2506	General requirements for screed board concrete vibrators.
99.	IS: 3366	Specification for pan vibrators
100.	IS: 3558	Code of Practice for use of immersion vibrators for consolidating concrete
101.	IS: 4656	Specifications for form vibrators for concrete.
102.	IS: 4925	Specification for concrete batching and mixing plant.
103.	IS: 11993	Code of Practice for use of screed board concrete vibrators.
Formwork		
104.	IS: 4990	Specifications for plywood for concrete shuttering work
105.	IRC: 87	Guidelines for the design and erection of false work for road bridges.
106.	IS: 806	Code of practice for use of steel tubes in general building construction.
107.	IS: 1161	Specification of steel tubes for structural purposes.
108.	IS: 1239	Specification for mild steel tubes, tubular and other wrought steel fittings
Gypsum and Gypsum Board		
109.	IS: 2095	Gypsum plaster boards
110.	IS: 2542 (Part 1/Sec to 12)	Methods of test for gypsum plaster, concrete and products: plaster and concrete
111.	IS: 2542 (Part 2/Sec 1 to 8)	Methods of test for gypsum plaster, concrete and products: Gypsum products
112.	IS: 2542 (Part1)	Gypsum building plaster: Excluding premixed

Sr. No.	Code No.	Code Name
		lightweight plaster
113.	IS: 2547 (Part 2)	Gypsum building plaster: Premixed lightweight plaster
Handling and Storage		
114.	IS:4082	Recommendation of Stacking and Storage of construction materials
115.	IS:8348	Code of practice for stacking and packing of stone slabs for transportation
116.	IS:8759	Code of practice for maintenance and preservation of stones in building
Instruments for Testing Cement and Concrete		
117.	IS:5513	Specification for Vsicat apparatus.
118.	IS:5514	Specification for apparatus used in Le-Chatelier test.
119.	IS:5515	Specification for compaction factor apparatus.
120.	IS:7320	Specification for concrete slump test apparatus.
121.	IS:7325	Specification for apparatus to determine constituents of fresh concrete.
122.	IS:10080	Specification for vibration machine.
123.	IS:10086	Specification for moulds for use in tests of cement and concrete.
124.	IS:10510	Specification for vee-bee consistometer.
Joint Fillers		
125.	IS:1838 (Part 1)	Preformed fillers for expansion joint in concrete pavements and structures (non extruding and resilient type): Bitumen impregnated fibre
Paints and Coatings		

Sr. No.	Code No.	Code Name
126.	IS:102	Ready mixed paint, brushing, red lead, non-setting, priming
127.	IS:109	Ready mixed paint, brushing, priming, plaster, to Indian Standard Colour No. 361 and 631 white and off white.
128.	IS:218	Creosote and anthracene oil for use as wood preservatives
129.	IS:347	Varnish, shellac, for general purpose
130.	IS:348	French Polish
131.	IS:2074	Ready mixed paint, air drying, red oxide-zinc chrome, priming
132.	IS: 4833	Methods of field testing of preservatives in wood
133.	IS:10013 (Parts 1 to 3)	(Part -1) Water soluble type wood preservatives
134.	IS:10013 (Parts 1 to 3)	(Part-2) Acid-copper-chrome preservative
135.	IS: 10013 (Part 1 to 3)	(Part-3) Copper-chrome-boron wood preservative
136.	BS:6496	Specification for powder organic coatings for application and stoving to aluminium alloy extrusions, sheet and preformed sections for external architectural purposes, and for the finish on aluminium alloy extrusions, sheet and preformed sections coated with powder organic coatings
137.	BS:EN:10152	Specification for electrolytically zinc coated cold rolled steel flat products. Technical delivery conditions
138.	ASTM A 164-71	Specification for electrodeposited coatings of zinc on steel
Pigment for cement		

Sr. No.	Code No.	Code Name
139.	BS:1014	Specification for pigments for Portland cement and Portland cement products
Reinforcement & Structural Steel		
140.	IS:206	Code of Practice for use of Steel Tubes in General Building Construction
141.	IS:210	Grey Iron Castings
142.	IS:280	Mild steel wire for general engineering purposes
143.	IS:432	Part I. Mild steel and medium tensile steel bars. Part II Hard drawn steel wire.
144.	IS:451	Technical Supply conditions for Wood Screws
145.	IS:806	Code of practice for use of steel tubes in general building construction
146.	IS:815	Classification coding of covered electrodes for metal arc welding of structural steels
147.	IS:1239	Specification for mild steel tubes, tubulars and other wrought steel fittings
148.	IS 1343	Code of Practice for Prestressed Concrete
149.	IS:1363	Black hexagon bolts, nuts and lock nuts and black hexagon screws.
150.	IS:1365	Slotted countersunk screws.
151.	IS:1566	(Part I) Specifications for hard-drawn steel wire fabric for Concrete reinforcement
152.	IS:1786	Specification for high strength deformed steel bars and wires for concrete reinforcement.
153.	IS:2502	Code of Practice for bending and fixing of bars for concrete reinforcement.
154.	IS:2629	Recommended practice for hot-dip galvanising of

Sr. No.	Code No.	Code Name
		iron and steel.
155.	IS:2751	Code of Practice for welding of mild steel plain and deformed bars for reinforced concrete construction.
156.	IS 4000	Code of practice for high strength bolts in steel structures
157.	IS:4759	Hot-dip zinc coating on structural steel and other allied products.
158.	IS:5525	Recommendations for detailing of reinforcement in reinforced concrete works
159.	IS:9417	Recommendations for welding cold-worked steel bars for reinforced concrete construction.
160.	IS:14268	Uncoated stress relieved low relaxation steel class 2 for Prestressed concrete
161.	IS:226	Structural steel (Standard Quality)
162.	IS:800	Code of practice for use of structural steel in general building construction.
163.	IS:813	Scheme of symbols for welding
164.	IS:814	Covered electrodes for metal arc welding of structural steel. (Part I & Part II)
165.	IS:816	Code of practice for use of metal arc welding for general construction in mild steel.
166.	IS:822	Code of practice for inspection of welds.
167.	IS:961	Structural steel (High Tensile)
168.	IS:1024	Code of practice for use of welding in bridges and structures subject to dynamic loading.
169.	IS:1030	Carbon steel casting for General Engineering Purposes

Sr. No.	Code No.	Code Name
170.	IS:1120	Coach Screws
171.	IS:1367	Technical Supply Conditions for Threaded Fasteners
172.	IS:1161	Steel tubes for structural purposes.
173.	IS:1182	Recommended practice for radiographic examination of fusion welded butt joints in steel plates.
174.	IS:1915	Code of Practice for Steel Bridges
175.	IS:2016	Plain Washers
176.	IS:2062	Structural steel (Fusion welding quality)
177.	IS:3063	Single Coil Rectangular Section Sprint Washers for Nuts, Bolts and Screws
178.	IS:3443	Crane Rail Sections
179.	IS:3757	Specification for high tensile friction grip bolts
180.	IS:5624	Specification for foundation bolts
181.	IS:3600	Code of practice for testing of fusion welded (Part I) joints and weld metal in steel
182.	IS:4923	Hollow steel sections for structural use.
183.	IS:6227	Code of practice for use of metal arc welding in tubular structure.
184.	IS:801	Code of practice for use of cold formed light gauge steel structural members in general building construction.
185.	IS:811	Specifications for cold formed light gauge structural steel sections.
186.	IS:8500	Structural steel Micro alloyed (Medium and high strength qualities)

Sr. No.	Code No.	Code Name
187.	IS:8910	General requirements of supply of weldable structural steel
188.	IS:9595	Recommendations for metal arc welding of carbon & carbon- manganese steels.
189.	IS 16172	Reinforced Couplers for Mechanical Splices of Bars in Concrete
Sand		
190.	IS:383	Coarse and fine aggregates from natural sources for concrete.
Scaffolding		
191.	IS:2750	Specification for steel scaffoldings
192.	IS:3696 (Part 1)	Safety Code of scaffolds and ladders: Scaffolds
193.	IS:3696 (Part 2)	Safety Code of scaffolds and ladders: Ladders
194.	IS:4014 (Part 1)	Code of practice for steel tubular scaffolding: Definition and Materials
195.	IS:4014 (Part 2)	Code of practice for steel tubular scaffolding: Safety regulations for scaffolding
196.	IRC:87	Guidelines for the design and erection of falsework for Road bridge
Sealants		
197.	IS: 10959	Glossary of terms for sealants for building purposes
198.	IS: 11433 (Part 1)	One part grade polysulphide base joint sealant: General requirements
199.	IS: 11433 (Part 2)	One part grade polysulphide base joint sealant: Methods of test
200.	IS: 13055	Methods of sampling and test for anaerobic adhesives and sealants

Sr. No.	Code No.	Code Name
201.	BS: 5889	Specification for one part gun grade silicone based sealants.
Wood		
202.	IS: 303	Plywood for General Purposes
203.	IS: 848	Synthetic resin adhesives for plywood (phenolic and aminoplastic)
204.	IS: 1141	Seasoning of Timber – Code of Practice
205.	IS:1328	Veneered decorative plywood
206.	IS: 1659	Blocks Boards
207.	IS: 2046	Decorative thermosetting synthetic resin bonded laminated sheets
208.	IS: 2202 (Part 1)	Wooden flush door shutters (solid core type): Plywood face panels
209.	IS: 2202 (Part 2)	Wooden flush door shutters (solid core (type): Particle face panels and hardboard face panels
Bearing		
210.	IRC: 83 Part-II	Standard specifications and code of practice for road bridges Elastomeric Bearings
211.	IRC: 83 Part-III EN 1337gh	Standard specifications and code of practice for road bridges Pot Bearings
212.	IRC: 83 Part-IV	Standard Specifications and Code of Practice for Road Bridges (Section – IX) Bearings (Spherical and Cylindrical)
Piling		
213.	IS: 2911 (All Parts)	Bored Cast in-situ Concrete Piles
214.	IRC: 78	Standard specifications and code of practice for road

Sr. No.	Code No.	Code Name
		bridges Foundation And Substructure
All Indian Railway & RDSO Standards, any other code or publication as approved by engineer in-charge		
Metal		
215.	IS: 276	Austenitic manganese steel castings
216.	IS: 733	Wrought aluminium and aluminium alloy bars, rods and sections for general engineering purpose.
217.	IS: 737	Specifications for wrought aluminium and aluminium alloy sheet and strip for general engineering purpose.
218.	IS: 3614 (Part 1)	Specification for fire check doors: Plate metal covered and rolling type
219.	IS: 3614 (Part 2)	Specification for metallic and non-metallic fire check doors: Resistance test and performance criteria
220.	IS: 7196	Specification for Hold Fast
221.	ASME set 2 Part A	Ferrous Material Specification
222.	ASTM B 221	Specification for aluminum-alloy extruded bars, rods, wires, shapes, and tubes
223.	BS: 4873	Specification for Aluminum alloy windows
224.	BS: 7352	Specification for strength and durability performance of metal hinges for side hanging applications and dimensional requirements for template drilled hinges
225.	BS EN: 10143	Specification for continuously hot-dip metal coated steel sheet and strip. Tolerances on dimensions and shape

Sr. No.	Code No.	Code Name
Stone and Facings/Linings		
226.	IS:1121-(Parts 1 to 4)	Methods of test for determination of strength properties of natural building stones
227.	IS:1121-(Parts 1 to 4)	(Part-1 Compressive strength)
228.	IS:1121-(Parts 1 to 4)	(Part-2 Transverse strength)
229.	IS:1121-(Parts 1 to 4)	(Part-3 Tensile strength)
230.	IS:1121-(Parts 1 to 4)	(Part-4 Shear strength)
231.	IS:1122	Method of test for determination of true specific gravity of natural building stones.
232.	IS:1123	Method of identification of natural building stones.
233.	IS:1124	Method of test for determination of water absorption, apparent specific gravity and porosity of natural building stones.
234.	IS:1125	Method of test for determination of weathering of natural building stones
235.	IS:1126	Method of test for determination of durability of natural building stones.
236.	IS:1127	Recommendations for dimensions and workmanship of natural building stones for masonry work.
237.	IS:1128	Specification for Limestone (Slabs and Tiles)
238.	IS:1129	Recommendation for dressing of natural building stones.
239.	IS:1130	Specification for marble (blocks, slabs and tiles)
240.	IS:1597 (Part 2)	Code of practice for construction of stone masonry Ashlar masonry

Sr. No.	Code No.	Code Name
241.	IS:1706	Method for determination of resistance to wear by abrasion of natural building stones
242.	IS:1805	Glossary of terms relating to stones, quarrying and Dressing
243.	IS:3620	Specification for laterite stone block for masonry
244.	IS:3622	Specification for Sandstone (slab & tiles)
245.	IS:4101 (Part 1)	Code of practice for external facing and veneers: stone Facing
246.	IS:4101 (Part 2)	Code of practice for external facing and veneers: Cement concrete facing
247.	IS:4101 (Part 3)	Code of practice for external facing and veneers: Wall tiling and mosaics
248.	IS:4121	Method of test for determination of water transmission rate by capillary action through natural building stones
249.	IS:4122	Method of test for surface softening of natural building stones by exposure to acidic atmospheres
250.	IS:4348	Method of test for determination of permeability of natural building stones
251.	IS:5218	Method of test for toughness of natural building stones
252.	IS:8381	Recommended practice for quarrying stones for construction purposes
253.	IS:14223 (Part 1)	Polished building stones: Granite
254.	BS: 8298	Code of practice for design and installation of natural stone cladding and lining

CHAPTER-2.**SITE INSTALLATIONS AND SERVICES****2.1 GENERAL**

- 2.1.1** Site installations, site clearance (including removal), services shall be carried out in accordance with the provisions of the Employer's Requirements.
- 2.1.2** The Contractor shall be responsible for providing plant, equipment, materials and labour for the provision of all necessary Temporary Works and services adequate for the execution of the Work under this contract.
- 2.1.3** The Contractor shall design, furnish, install, maintain and operate on the Site Constructional Plants as specified in this Chapter, including camps, workshops: warehouses, storage and assembly areas, all equipment, machinery, vehicles. Scaffolding, water and power supply etc.
- 2.1.4** Obtaining necessary clearance/ permission that are needed for construction, from various state/ central authorities for the equipment, water, power, sanitary and explosives shall rest with the Contractor.
- 2.1.5** Temporary Works and services carried out by the Contractor shall conform to the applicable Indian Standard Codes / laws, regulations and statutory requirements including compliance to railways codes/manuals/guidelines etc. stipulated for such purpose. In-case no National Standard is available, International Standards are to be applied as approved by the Engineer.
- 2.1.6** The design, construction, operation and maintenance of the Contractor's Temporary Works and services shall be subject to inspection and approval by the Engineer.
- 2.1.7** The rights or customs of adjacent property occupiers for access shall not be infringed by the Contractor.

2.2 SUBMITTALS

- 2.2.1** Within 28 days from the Letter of Acceptance, the Contractor shall submit to the Engineer, updated layout plans showing, to an adequate scale, the locations and arrangement of all enabling and temporary Works and facilities. These plans shall be consistent with the plans submitted by the Contractor with his tender as well as with any amendments and additions subsequently agreed to by the Engineer and the Contractor and shall include:
- i. Site offices, storages, parking areas, warehouses, materials yard, storage areas
 - ii. Concrete and material processing plant including cement storage.
 - iii. Temporary road including public road diversions.
 - iv. Communication System.
 - v. Service vehicles.
 - vi. Camps for Contractor's Employees.
 - vii. Medical facilities.

- viii. Power supply and illumination, telephone services (radio and cable).
- ix. Maintenance of Traffic.
- x. Ventilation of Underground System.
- xi. Air-cooling in underground works.
- xii. Control of dust, silica and noxious gases in underground works.
- xiii. Water supply.
- xiv. Sanitation & sewerage, sewage treatment and disposal,
- xv. Waste & garbage disposal.
- xvi. Security and safety arrangements.
- xvii. Field laboratory along with list of equipment as required under Quality Assurance Programme.
- xviii. Equipment tools and mechanical workshops.
- xix. Dumping areas, borrow, quarry and stockpile areas with development plans.
- xx. Explosive magazines.
- xxi. Adequate back up power system.
- xxii. Measures to comply with environmental norms and various conditions.
- xxiii. Muck disposal management.
- xxiv. Site Signage.
- xxv. Drainage plan during construction.
- xxvi. Contractor Quality Plan
- xxvii. Emergency Plan.
- xxviii. Safety Plan

2.2.2 Within 42 days from the commencement date, the Contractor shall submit to the Engineer the following:

- i. Detailed drawings to a scale ranging from 1:100 to 1:500 showing the camp layout, buildings, roads, recreation areas, all utilities etc. and drawings to a scale of 1: 50 to 1: 100 showing typical building construction details.
- ii. Drawings and Specification for the establishment of primary first aid stations dispensary and ambulances.
- iii. Detailed design for industrial and potable water supply to the camps and working area as well as sewerage system, sewerage treatment and disposal with an estimate of number of people to be supplied with water. All the system shall comply with the environmental and pollution control norms as applicable.
- iv. Detailed layout drawings for electrical installations and distribution systems on the site, showing voltages, outlets and routing of power lines. The system

should include necessary power back up arrangements for uninterrupted construction work.

- v. Detailed design and drawings including manufacturer's drawings for concrete and materials processing plants, including details of equipment for transportation and placement of concrete in accordance with the requirements of the pertinent Chapters of these Specifications.
- vi. Details of the excavation, drilling and grouting equipment in accordance with the requirements set out in the relevant Chapter of these Specifications.
- vii. Details of the underground ventilation system, which shall include all calculations of fresh air supply volume, type of ventilation scheme, duct diameters. Materials, equipment, position of ventilators and dust arresters. Description of the working cycle including number of persons employed, number and capacity of diesel-powered equipment working at each heading face shall also be included.
- viii. Details of the dewatering system.
- ix. Details of Field laboratory to be set up at site by the Contractor.
- x. Details of muck disposal and protection measures for compliance with Environmental, Social, Health & Safety Management Plan of the work specifications.
- xi. The designs shall be consistent with the proposal submitted by the Contractor with his tender as well as with any subsequent amendments and additions agreed to by the Engineer and the Contractor. (The Engineer reserves the right to require any additional information deemed necessary to be included in the submitted documents.)

2.3 DETAILS OF INSTALLATIONS AND SERVICES

The installations and services to be provided by the Contractor for the execution of Works under this Contract shall include, but not limited to, the following:

2.3.1 CAMPS FOR CONTRACTOR'S EMPLOYEES

The Contractor shall design, construct, provide furnishings, maintain and operate construction camps at the suitable locations *as per provisions of Appendix 13: ESHS Manual, Section VII-9: Appendices, Part 2 – Employer's Requirements.*

2.3.2 The sewerage from the labour camps, work sites is to be properly treated before discharge by providing septic tanks, soak pits etc. or any other treatment as per norms recommended by the concerned authority.

- i. Canteen facilities shall be provided by the Contractor in properly equipped canteen buildings for all his and his subcontractor's employees, if it is considered expedient.
- ii. The Contractor shall be responsible for keeping the camps and buildings within it, in good hygienic conditions. The standards regulations presently in

force in the project area with regard to water treatment, sanitary conditions, and fire and accident prevention shall be duly taken into account.

2.3.3 Site Offices, Stores, Warehouses, Materials Yards

- i. The Contractor shall provide and equip, for his own and his subcontractors' use, main and secondary offices, warehouses, materials stock areas, fuel storage areas and explosive magazines, all of which shall be maintained in good condition until the completion of Works.
- ii. The buildings and warehouses expected to be constructed and equipped by the Contractor for use in the execution of the Works under this Contract, in addition to the facilities explicitly specified elsewhere in these Specifications shall be, but not limited to, the following:
 - a. Mechanical repair shop
 - b. Electrical repair shop
 - c. Metalwork fabrication and carpentry shop
 - d. Main warehouse and parts store
 - e. Bulk cement silo/cement store
 - f. Spare parts store.
- iii. No dangerous goods, explosives, chemicals, fuels or similar items shall be brought onto the Site unless the Contractor has advised the Engineer of the intention to do so and has complied with all statutory requirements for its safe storage and security.
- iv. The Contractor shall minimize the use of the Site for the storage of fuels, explosives and other dangerous goods as may be required for the construction of the works and shall not use the site or allow access for any purpose not connected to the Contract.
- v. Dangerous Goods are only to be stored in nominated and approved storage areas and facilities which must comply with the Indian regulations governing such facilities.
- vi. The Contractor has to make appropriate provision for material storage sheds and tarpaulin sheets for loose construction material.
- vii. The Contractor has to make appropriate provision for dustbins and corresponding disposal of waste at labour campsite and at each work site.

2.3.4 Concrete and Materials Processing Plants

- i. The Contractor shall install and erect all necessary material processing plants of sufficient capacity to meet the planned peak requirements during construction. The plants shall be subject to approval by the Engineer and shall be well designed and fabricated and kept in good running order to ensure compliance with the materials quality Specifications. All control and measuring equipment shall be regularly serviced and calibrated.

- ii. The plants required to be assembled/erected by the Contractor shall be but not limited to the following:
 - a. Concrete plant (batching and mixing)
 - b. Concrete cooling plant (refrigeration and ice plant), if required.
 - c. Grouting plant.
- iii. Concrete & material processing plants shall meet all environment guidelines, conditions imposed for construction of project by MOEF/ Government bodies/ State pollution control boards and other statutory bodies at no extra cost to the Employer.

2.3.5 Temporary Roads

The Contractor shall construct temporary roads / hauls roads, to various facilities. Contractor shall develop detailed drawings for the above and accordingly construct the same after approval of Engineer.

2.3.6 Communication System

- i. Outside / Site Communication
- ii. The Contractor shall install his communication system in the project area for national/ international voice and data communication. These facilities can be availed from the existing network of tele-communication or the Contractor shall make arrangement for providing these facilities through existing telecom operators.
- iii. Communication System in Underground Works
 - a. Communication systems for underground space shall comprise of telephone/radio systems (walkie-talkie).
 - b. The Contractor shall install and maintain in operating condition, communication system by telephone or preferably an underground radio system approved by the Engineer between each heading face and entrance to the concerned tunnel / caverns. All the employer's site offices shall be well connected with the above communication system.
 - c. In case of telephone system, an intermediate Intercom station shall be located at least every 250m or less along the tunnel.
 - d. All Communication system shall have sources of energy independent of the main energy supply for Underground works.
 - e. The availability of the communication from inside to outside the tunnel shall be ensured at all times throughout the duration of the underground construction.

2.3.7 Check In/Check Out Procedure for all persons entering any underground space:

- i. The Contractor must maintain an approved check-in/check-out procedure (in

form of Name tag boards and RFID/Biometrics) to ensure that above ground personnel maintain an accurate accounting of the number of persons underground and to prevent unauthorized persons from gaining access to the site.

- ii. At any time when underground operations are underway, at least one designated person must be on duty above ground. This person is responsible for calling for immediate assistance and keeping an accurate count of employees who remain underground in the event of an emergency.
- iii. In addition to establishing a check-in/check-out procedure, the Contractor must ensure safe access to and egress from all workstations at the construction site to protect employees from potential hazards, such as being struck by excavators, haulage machines, or other moving equipment.
- iv. To help control access, all unused openings, including chutes and man ways, must be tightly covered, bulk headed, barricaded, or fenced off, and posted with warning signs that read, "Keep Out" or similar language.
- v. RFID system/Bio-metric system for entry record into tunnel for all staff of contractor, employer and employer's representatives. Contractor shall submit record of entry and exit of all staff (Name, Personnel Type, Age, Gender and Agency) along with date and time every 1st and 15th date of month to the employer. The system should be able to transmit all recorded data between the desired dates through USB drive etc. Further the system should be able to generate fresh RFID tags/Bio-Metric entries when required for entry of new personnel previously not registered with the system.

2.3.8 Entry/Exit records for all vehicles (Employer, Contractor, Consultant etc.) including tunneling machineries entering any underground space:

- i. The Contractor must maintain an approved Entry/Exit record (in form of RFID TAG system) to ensure that above ground personnel maintain an accurate record of time of Entry/Exit and prevent unauthorized vehicles from gaining access to the site.
- ii. At any time when underground operations are underway, at least one designated person must be on duty above ground. This person is responsible for calling for immediate assistance and keeping an accurate count of the number and type of vehicles in the event of an emergency.
- iii. RFID TAG System for record of entry/exit time for all vehicles: Contractor shall submit time record of entry and exit of all vehicles (Registration number, Vehicle Type and Agency) along with date and time every 1st and 15th date of month to the employer. The system should be able to transmit all recorded data between the desired dates through USB drive etc. Further the system should be able to generate fresh RFID tags when required for entry of new vehicles previously not registered with RFID system.

2.3.9 SERVICE VEHICLES

- i. The Contractor shall furnish, operate and maintain sufficient service vehicles for use by his own staff and employees in the management, supervision and performance of the Work.

2.3.10 MEDICAL FACILITIES

The Contractor shall provide medical facilities *as per provisions of Appendix 13: ESHS Manual, Section VII-9: Appendices, Part 2 – Employer's Requirements.*

2.3.11 POWER SUPPLY AND ILLUMINATION

- i. General.
 - a. Contractor has to make his arrangements at his own cost for entire construction power including any standby power requirements. Equipment/ transmission lines required for distribution and utilization of energy at Construction site for Power, light etc. shall be installed by the Contractor on their own.
 - b. Power to be used by Contractor for their Labour and Staff Colony shall be arranged by contractor on their own and at their own cost.
 - c. Contractor shall arrange DG sets of adequate capacity at his cost to meet back up and emergency power supply requirement including lighting, dewatering & ventilation.
 - d. Contractor shall indicate in his proposal of the phase wise requirement of Construction power (HT) at above-mentioned locations.

- ii. Power supply and Illumination provided by the Contractor
 - a. The Contractor shall install, operate and maintain electrical distribution system, which shall include transformers, circuit breakers, disconnection and safety switches, voltage regulators, lines, poles, pole hardware, conductors, meters and other equipment necessary for power distribution throughout the Site and temporary facilities.
 - b. An alternative source of emergency lighting system shall be provided every 50m at key points underground to allow emergency securing operations and evacuation safely in the event of a primary power failure.
 - c. The Contractor shall ensure adequate illumination for all his operations on the Site and at the Camps, including illumination of the streets. The Contractor shall maintain equipment and arrange device to measure light intensities for illumination as follows:

	Area of Operation	Luminous Intensity
(a)	Excavation and dumping areas and outdoor access ways	35 Lux

	Area of Operation	Luminous Intensity
(b)	General construction areas, concrete placement, excavation and waste areas, access ways, active storage areas, loading platforms, refueling, and field maintenance areas.	50 Lux
(c)	Indoors: warehouses, corridors, hallways, and exit ways.	50 Lux
(d)	Tunnel and general Underground Work areas	50 Lux
(e)	Tunnel headings during drilling, mucking and scaling	100 Lux
(f)	General construction plant and shops, e.g. batching plants, mechanical and carpentry shops, active storerooms, barracks or living quarters, mess halls and indoor toilets	100 Lux
(g)	First aid stations, infirmaries and offices.	350 Lux
(h)	Welding	300 Lux

- d. The vaults along the entire length of the tunnel shall be illuminated with electrical light throughout the duration of, construction works. The lamps shall be provided in two rows with each row lamp spacing of 10 m in unlined stretches and 20 m in lined stretches. Contractor shall suitably modify the spacing and capacity of lights to meet the illumination requirements mentioned above.
- e. Electrical cables shall be well insulated, protected and firmly fixed to the walls of the tunnel by means of adequate insulators; lamps shall be well protected against damage.
- f. The Contractor shall also provide suitable movable lamps to illuminate any area in Underground Works including areas for instrumentation and where the Engineer may wish to carry out inspection and rock mechanics tests or instrumentation.
- g. No energized electrical cable shall be permitted nearer than 70 m to the heading face while charging explosives. Accordingly, suitable high-powered light arrangement shall be made to have adequate illumination at the tunnel face.
- h. Lighting illumination by flame is expressly forbidden in the Underground Works.
- i. Whenever more than one agency is working in the same area, the Contractor, who has already provided lighting I Power supply

arrangements, shall extend the facilities to the other Contractor, who shall pay for such facility of utility at mutually agreed rates. In case of disputes, the matter shall be decided by the Engineer, whose decision shall be final.

iii. Earthing of Wet work Areas, Control of Electric Discharges

- a. All equipment and appliances, which are exposed to lightning, shall be earthed electrically, and the Contractor's specialized personnel shall periodically check the effectiveness or such earthing.
- b. Personnel standing in water shall operate no equipment electrically powered by more than 24 Volts.
- c. Only air, battery-powered or hydraulic tools shall be permitted in the wet areas.
- d. Where electrical blasting is used, equipment shall be installed to control possible electric discharge in the ground due to storms, electric motors, etc. As soon as such discharges are noted, electrical blasting operations shall be suspended, or the detonator type changed.

2.3.12 MAINTENANCE OF TRAFFIC

- i. The Contractor shall be responsible for the safety along the roads related to the Site. Where the work is carried out on the Site of, or close to an existing road, the Contractor shall maintain the vehicular and pedestrian traffic safe at all times. If his operations can cause traffic hazards, he shall repair or fence or take such other measures for ensuring safety that are satisfactory to the Engineer.
- ii. The Contractor shall submit his activity, schedule and the locations of his work along the existing public roads to the authorities concerned and obtain all necessary approval prior to the commencement of the respective work.
- iii. At the road crossings or in heavy traffic locations, the Contractor shall carry out the Work within the working hours as directed by the Engineer, and after the completion of the work he shall immediately make the necessary backfill and pavement at the crossings.
- iv. The Contractor shall provide temporary passes and badges to give an access to the existing village houses, etc., to the satisfaction of the Engineer and the authorities concerned whenever he disturbs such existing way during the execution of works.

2.3.13 VENTILATION OF UNDERGROUND WORKS

- i. General
 - a. The Contractor shall design, install and operate ventilation system for

- the Underground Works and provide an underground atmosphere monitoring system.
- b. All parts of the Works shall be maintained in a state, which will not be injurious to the health or the personnel. The air in underground works shall contain no less than 20% oxygen (by volume) and shall not contain concentration of gases, vapors or dust greater than is prescribed in the safety standards for the health or workmen.
 - c. If required, the ventilating system shall be kept in operation also after break-through in tunnels in order to maintain the fresh air-volume requirements stated hereinafter.
 - d. Intermediate fans attached to the main dual line shall be provided as required to ensure satisfactory removal of contaminated air. All ventilation ducts shall be maintained in a good condition to prevent any leakage.
 - e. Ventilation ducts shall be firmly fixed to the vaults in such position that a minimum clearance of 30 cm remains between the duct and the extremities of vehicular traffic employed in the Underground Works.
 - f. The Contractor shall ensure the required quantity of fresh air at the heading face. The check of the airtightness of joints and control of the air ducts for leaks shall be performed periodically. The Contractor shall immediately repair any deficiency discovered or reported by the Engineer.
 - g. If the volume and quality of fresh air at the heading face is less than that specified, then the whole duct system shall be pressure and volume tested in portions not exceeding a few hundred meters. Measuring stations shall be located not closer than 10 times the duct diameter from any fan or other flow disturbance within the Main Line.
 - h. No work shall be permitted to be carried out unless the ventilation is provided to the satisfaction of the Engineer. Indoor Air Quality standards as described in EPA,1986 (with latest amendments) be adhered to.
- ii. Ventilation System for Tunnel excavation
- a. The ventilating system shall be of such efficiency that the average air velocity in the largest excavated profile is not less than 0.3 meters per second. In case the presence of methane gas is detected or suspected, this value shall be increased to 0.5 meters per second.
 - b. The main ventilation system shall ensure that both following minimum fresh air volume requirements are satisfied at all times:
 - (a) 5.70 m³ per minute for each person employed in the Underground Works at one time.

- (b) A minimum of 2.00 m³ of air per minute shall be supplied additionally for each metric horsepower of diesel-powered equipment deployed in the underground works alone time.

These fresh air volumes shall be cumulative, and the Contractor shall allow, in his design calculations, for the maximum number of persons and diesel-powered equipment deployed in the Underground Works at any one time. Any estimated losses, e.g. due to the leaks in the ducts, shall be added to the figures stated above.

- c. The secondary ventilation equipment of the forced type shall be installed to provide an adequate ventilation of the area between the heading face and the air intake/outlet of the main system. This system shall be switched on prior to the blasting and shall remain operative until the main system has been put into exhaust mode of operation. The air intake shall be located at a sufficient distance from the heading face to ensure that blasting fumes do not permeate into this area and cause a recycling of blasting fumes. The outlet of this duct shall be located so close to the heading face that the driving of the blasting fumes and dust away from the face into main system is ensured. The minimum capacity shall be at least 70% of the main system's capacity. The end diameter of the duct shall be such that the air discharge velocity is not less than 20 meters per second.
- d. Re-entry into the heading face and resuming of the work shall not be permitted until all blasting fumes have been ejected out.
- e. Subject to meeting the minimum functional and safety requirements of ventilation the engineer may allow other systems of ventilation also as proposed by contractor. This shall in no way absolve contractor from his obligation to meet the necessary requirements of ventilation at any time during work.
- f. All equipment and ventilation duct shall always be maintained in sound working order. Any damage to ventilation duct shall be repaired within 12 hours of the damage.
- g. Ventilation ducts must be maintained in straight alignments as much as possible and with plain cross sections avoiding unnecessary curves, reduction and rotations of the cross sections and always without any damage of the ducts.
- h. Ventilation ducts must follow the advance of the tunnel excavation, being the extremity of the duct no more distant from the front face than 20m. In any case this distance shall be reduced if the quality of the air in the front face does not follow health and safety specifications.
- i. Whenever excavation proceeds more than 2 kms from any portal then contractor will be required to install booster ventilation fans to enhance

ventilation capacity and install LT lines to reduce transmission loss over long lengths if other methods are not effective, for which nothing extra shall be paid.

2.3.14 AIR COOLING IN UNDERGROUND WORKS

- i. The Contractor shall make suitable arrangements for cooling of air so as to maintain the temperature in the underground construction sites below 300 Centigrade under all conditions.
- ii. The temperature shall be measured by the Contractor daily. Temperature measurements shall be taken during normal working conditions with the specified degree of ventilation.
- iii. The maintenance of construction progress and control of temperature shall be entirely the responsibility of the Contractor under all conditions. No claim or extension of time for the completion of Works shall be allowed on this basis of high / low temperatures experienced in the course of the work for any reasons, whatsoever. However, Geo-thermal conditions are not anticipated by employer, Temperature meter for measurement of temperature shall be supplied and or installed & maintained at required location by contractor at his own cost.

2.3.15 CONTROL OF DUST, SILICA AND NOXIOUS GASES IN UNDERGROUND WORKS

- i. The Contractor shall install and operate equipment for the monitoring and Control of dust, silica and noxious gases in Underground Works as described here under.
- ii. Dust and Silica
 - a. To reduce the amount of dust, only wet drilling will be allowed and during mucking, muck piles shall be kept constantly damp by sprinkling with water. The use of high-pressure water jets for this purpose will not be permitted.
 - b. The Contractor shall measure and monitor the concentration of fine dust and content of silicon dioxide. (SiO₂) in all dust producing underground operations by a method to be approved by the Engineer.
 - c. Air Samples shall be taken within 10 days of commencing underground excavation, at 30 days intervals thereafter and within 20 days following major changes in tunnel excavation operation, or whenever required by the Engineer. Samples shall be taken from actual working areas. A qualified person in laboratory to be proposed by the Contractor and approved by the Engineer shall perform the sampling and testing. A copy of the test results shall be submitted to the Engineer within 2 weeks of the sampling date.

- d. The concentration of fine dust (diameter less than 0.005 mm) may not, in general exceed the value of 8.0 mg/m³ of air and this value will be further reduced depending upon the extent of SiO₂ content in rock as detailed in the table below:

Content of SiO₂ in fine dust in percent by weight.	Concentration of fine dust in milligrams per cum of air.
1-15 %	8.0 mg / M ³
20 %	6.0 mg / M ³
30 %	4.0 mg / M ³
60 %	2.0 mg / M ³
80 %	1.5 mg / M ³
100 %	1.3 mg / M ³

- e. Should the concentration of the fine dust exceed the limits stated above, the Contractor shall undertake such necessary measures and install such additional equipment which will ensure that the dust concentrations are within the specified safe hygienic limits.
- f. All staff entering underground work site shall be equipped with PPE including respirators suited for the work.

iii. Noxious Gases

- a. Use of internal combustion engines, other than approved mobile diesel-powered equipment will not be permitted in underground construction Sites.
- b. The Contractor shall provide and maintain equipment for measuring and monitoring the content of noxious gases and oxygen at each heading face throughout the duration of excavation works. Tests for determining concentrations of carbon monoxide, carbon dioxide, nitrogen dioxide, methane, other inflammable gases, and oxygen Shall be made by qualified personnel before and after each blasting and at the beginning of each shift. A record of reading shall be maintained and be made available to the Engineer as and when asked for.
- c. Gas concentrations in underground sites will not exceed the following limits:

0.005 %	50 ppm of carbon monoxide.
0.5 %	5000 ppm of carbon dioxide.

0.0005%	5 ppm of nitrogen dioxide.
0.001%	10 ppm of hydrogen sulphide.
0.1%	1000 ppm of methane.
0.01 %	Milligrams per litre of nitrous oxide.

- d. After each blast, before entering the blast area, the concentration of toxic gases will be checked to ascertain the efficacy of ventilation system. The engineer in addition may direct the Contractor to measure the concentration of toxic gases during other operations also. Contractor will always keep all measuring instruments in a ready state. All such records shall be signed jointly by both parties immediately after measurement.
- e. Concentrations of other inflammable gases shall not exceed 40 % of the lower explosive limit at the heading face and 20 % of the lower explosive limit elsewhere in the tunnel.
- f. If concentrations of noxious gases or other inflammable gases exceed the permissible limits set forth above, all operations shall be interrupted immediately, and personnel shall be removed to a safe area. All sources of ignition shall be extinguished or removed. All equipment with the exception of ventilation equipment shall be shut down.
- g. The required measures will be mutually determined and agreed to by the Engineer and the Contractor. In case of need, the Contractor shall engage the services of an independent Consultant experienced in gaseous tunneling. Re-entry and resuming of the Work shall be prohibited until the Engineer has authorized re-entry.

2.3.16 WATER SUPPLY

- i. The Contractor shall design, Install, operate and maintain two separate water supply systems on the Sites
 - a. Industrial Water: For general construction use, treated to the extent necessary to meet specified requirements of Works.
 - b. Potable water: For supply to all buildings and plants requiring high quality water meeting requirements for drinking water supply.
- ii. Water shall be, supplied by the Contractor from any suitable sources. The water being supplied shall be free of contamination and unaffected by the Site construction Work.
- iii. The Contractor shall 1 furnish, install, operate and maintain all pumps, pipelines, fittings, valves, storage tanks purification plant and chlorination for the Water supply and distribution systems, adequate in quantity and pressure. Industrial water shall be used for construction purposes only. There shall be no cross connections of any kind between the industrial and potable water supply systems. Only potable water shall be piped into buildings.

- iv. The Contractor shall provide adequate water treatment facilities so as to ensure that the treated water is supplied for drinking purposes to all the camps and construction places.
- v. Ample number of drinking points of potable water shall be provided by the Contractor for the use of personnel in all working areas.

2.3.17 SANITATION AND SEWERAGE

- i. Toilets shall be provided and maintained by the Contractor for the use of all personnel at all work locations, which are remote from the fixed sanitary facilities. The Contractor shall arrange for all chemical toilets to be attended to daily for proper sanitary disposal.
- ii. All offices, workshops, laboratory and other occupied work buildings shall be provided with toilets connected to property constructed and regularly maintained septic tanks approved by the Engineer.
- iii. The camp sites shall be provided with a complete, properly maintained and operated sewerage system, including septic tanks, sewage treatment and disposal facilities. Facilities for washing clothes shall also be provided and linked to the sewerage system.
- iv. Sanitation, sewerage system and contaminated water from the tunnel excavation shall meet all environment guidelines conditions imposed for construction of project by MOEF / Government Bodies at no extra cost to the Employer.

2.3.18 DISPOSAL OF C & D WASTE

The Contractor shall make necessary arrangements for the management of muck disposal so that it meets all the environment guidelines / conditions imposed for the construction of project by MOEF / Govt. bodies / State Pollution control board and/or other statutory bodies.

2.3.19 WASTE AND GARBAGE DISPOSAL

- i. The Contractor shall daily collect waste material and garbage from camps, offices and workshops and transport it to an area approved by the Engineer, where it shall be incinerated and buried or disposed off as approved by the Engineer.
- ii. The site shall be kept clean and free of refuse at all times. No waste shall be dumped in areas other than those approved by the Engineer for waste disposal. No waste of any kind shall be deposited in any watercourses.
- iii. Waste and Garbage disposal system shall meet all environment guidelines and conditions imposed for construction of project by MOEF/ Govt. bodies at no extra cost to The Employer.
- iv. The Contractor has to make appropriate provision for Oil / Grease interceptor at refueling stations and at fuel storage locations.

2.3.20 SETTING UP OF FIELD LABORATORY

- i. The Contractor shall establish a field laboratory for ensuring quality control measures for the Works, as detailed under Quality Assurance Programme described elsewhere in the tender documents.
- ii. Prior to setting up of laboratory, Contractor shall submit detailed building plan with exhaustive equipment-list clearly showing the different area for equipment with sizes of the equipment and circulating area, and CV's of qualified personnel identified for laboratory work to the Engineer for approval. The laboratory shall be headed by an experienced graduate civil engineer. All the equipment shall be conforming to either the relevant IS or international standards.
- iii. Upon receipt of Engineer's approval, the Contractor shall construct, maintain and operate an integrated laboratory which provides sufficient rooms and equipment to test aggregates, concrete samples, plain shotcrete and SFRS samples, soil and rock samples, rock bolts capacity tests, nuclear gauge tests to control the density of the compacted layers for earthworks, etc. The laboratory shall be established as early as possible but not later than three months from the date of issue of Letter of Acceptance.
- iv. The Contractor shall collect the samples, carry out the relevant tests, prepare the complete reports and submit them to the Engineer.
- v. All tests will be made according to approved standards, and the testing equipment shall comply with the same standards. All relevant standards shall be made available in the laboratory by the Contractor.
- vi. The laboratory shall be provided with light, ventilation, water supply, tank for curing, toilet, office for operators and responsible for laboratory, archive etc. and be spacious enough in order to store indoor the test samples

2.3.21 LAND REQUIREMENT

- i. The Employer has acquired the required land for permanent components of the project work which shall be handed over to the Contractor on as is where is basis. Tender drawings show the available land acquired and major permanent structures required to be constructed. The Contractor shall organize the installation site in a way that his temporary buildings, plants, equipment etc. will not hinder the final/permanent works. The land shall be used primarily for execution of work of the project. The Contractor will seek approval of the Engineer for setting up of site facilities on land acquired for the project. Employer's land shall not be used for setting up of labour camps. Nothing additional will be paid for re-shifting of any plants and machinery to the Contractor. Extra land if needed by the Contractor for setting up of any of his facilities, such cost of land will be borne by the Contractor.
- ii. The Contractor shall submit his scheme of land utilization including muck disposal and subsequently construct the same after obtaining due approval of

the Engineer.

- iii. Muck generated in the works may be used by contractor for constructing his facilities / filling works etc. free of cost. The royalty payment and/or any cess leviable by the statutory authority shall however be payable by the Contractor by such usage.
- iv. Any Government duties, cess etc. levied by the statutory authority for land use outside *HORC* land shall be borne by the Contractor at no extra cost to the Employer.
- v. Before demobilization, the Contractor shall remove all his temporary facilities which were installed for execution of the work and restore the land to its original state for all such land used as in (i) above.

2.3.22 FENCING AND SITE SECURITY

- i. The Contractor's offices, workshops and storage compounds, camp sites and all construction areas, where exclusion of unauthorized personnel is necessary for safety and security, shall be adequately fenced, gated and guarded. A central guardhouse shall be established at each main entrance to the Site.
- ii. The Contractor shall employ adequate force of properly trained security guards at the worksite and at the construction camps on 24 hours duty including Sundays and holidays. Storage areas shall be fenced, lighted and regularly patrolled by security guards. Warehouse buildings and explosive magazines shall be kept locked and keys accounted for at all times.
- iii. All employees engaged in the execution and maintenance of the Works shall wear identification badges when at the worksite.
- iv. The Contractor shall be entirely responsible for the losses occurring in his installations and those of the Engineer, resulting from carelessness on the Contractor's part.
- v. The Contractor has to make appropriate provision for LED Lights on top of the barricading and provision of the noise enclosures over the tunnel portals.

2.3.23 SITE SIGNAGE

- i. Prior to the commencement of work at the Site, the Contractor, at the direction of the Engineer, shall supply and erect reflector site sign at all work sites for the information of the public at all entrances to the Site, containing the following information, clearly visible and legible (In English and Hindi language) to passersby intended for the information of those affected by the Contract Works, for the guidance of those making deliveries and for general public safety:
 - a. Name of Project;
 - b. Name of Employer;
 - c. Name of Contractor;

d. Restrictions on access and appropriate safety warnings.

- ii. The Contractor shall also maintain such signs throughout the contract period with up to date information and free from disfigurement.

2.3.24 The Contractor shall also supply, erect and maintain appropriate reflector site signage and safety warning signs as are appropriate for the nature of the work being undertaken. No other signage or advertising materials shall be permitted on the Site, except with the specific consent of the Engineer.

CHAPTER -3 SURVEYING

3.1 GENERAL

- 3.1.1** The employer has already established certain benchmarks and alignment references. These benchmarks and alignment markers are required to be validated by the Contractor. Any error found in these benchmarks and alignment markers shall be rectified by the Contractor with the approval of the Engineer. The Contractor is also required to maintain these benchmarks provided by the employer throughout the period of construction. The survey to be done by the Contractor shall be done by establishing the control points along the proposed railway alignment through the use of DGPS. All these control points will then be connected to the nearest GTS Benchmark using the Total Station *and Digital Auto level*.
- 3.1.2** These services cover in general transfer of control points to working area, the establishment of axis, centerlines, alignments of project structures and features, the setting out for construction thereof; the accompanying control surveys for correct locations, dimensions and elevations as well as the necessary surveys for measurement to permit quantity calculations for billing.
- 3.1.3** Such surveys shall be based on and/or referred to existing basic grid of datum points, triangulation points and benchmarks extended adjacent to the Work in the project area. This grid shall be the sole basis of reference for all survey work and measurement.
- 3.1.4** High precision direction measurement of the alignment shall be done at every approx. one km of excavation or as decided by the ENGINEER by use of surveying gyroscopes i.e Gyromat or similar, at the cost of the Contractor.
- 3.1.5** Contractor has to make the survey of the excavated profile and control the tunnel sections after mucking, after installation of the primary support, prior to the installation of the felt for the protection of the water proofing membrane and after the lining works all along the length of the tunnels to control alignment, envelopes, excavated areas, primary support thickness and the position of the work-forms and final lining geometry, thickness and areas. The quality plan to be submitted by the Contractor to the engineer should give a detailed methodology duly indicating the schedule required to cover all the aforesaid survey items that the Contractor has to deliver to Engineer and also has to include when the topographical survey of the tunnels and portals has to be carried out.
- 3.1.6** Responsibility of carrying out the work to correct line and level shall, however, continue to devolve on the Contractor notwithstanding the fact that approval for any benchmark and/or alignment marker may inadvertently have been accorded by the Engineer. Consequently, any expenditure incurred by the Contractor for rectification of the permanent and/or temporary works constructed to wrong line/level shall not be payable by the Employer.
- ### 3.2 SUBMITTAL
- 3.2.1** Within 28 days from the Letter of Acceptance, the Contractor shall submit to the Engineer for his approval a proposal of the sequence of the survey works to be

performed, the biodata of the key personnel & in-charge of survey works, the list of survey equipment and instruments the Contractor will have available at the site, and a brief outline on methodologies of survey works to be applied for the various types of survey.

- 3.2.2** At least 7 days prior to the commencement of any survey work, the Contractor shall inform the Engineer of his intention to perform the survey work. The Contractor shall indicate the purpose of the survey, the area to be surveyed, the structure or facilities involved, the methods to be applied and the survey period.

3.3 MATERIAL AND INSTRUMENTS

- 3.3.1** The Contractor shall provide, maintain and operate suitable and appropriate equipment, instruments, materials and auxiliary equipment, commensurate with various tasks and precision requirements of the survey works.
- 3.3.2** Type and accuracy of the survey equipment to be used by the Contractor shall correspond to the nature of the construction, erection works and the construction technique.
- 3.3.3** All equipment, instruments, materials and auxiliary equipment shall be in perfect operating condition. Prior to the start of survey activities, equipment, instruments, etc., shall be checked as to their proper functioning and accuracy.
- 3.3.4** During the construction period, the survey instruments shall be checked and adjusted / calibrated at regular time intervals.
- 3.3.5** Instruments and equipment which have suffered from use, damage or accidents to the extent that they are unfit for further use at the site, shall be removed from the site and replaced immediately.
- 3.3.6** The Contractor should ensure availability of sufficient quantity and quality of survey instruments including provision of professional staff, to avoid any delay in the construction.

3.4 EXECUTION

3.4.1 General

- i.** For the execution of the survey work the Contractor shall employ and provide experienced professionals and auxiliary staff. All survey and measurement work shall be recorded and filed thoroughly.
- ii.** The Contractor shall provide, maintain, adjust when necessary and operate the required survey and auxiliary equipment for the performance of the Work.
- iii.** All survey and measurement activities shall be recorded in maps and field books as directed/approved by the engineer. Where required, the production of drawings and maps shall be deemed to be part of the work.
- iv.** The Engineer shall have the right to check work performance, accuracy stations, etc., and all survey results, measurements and calculations as well as conformity with plans and drawings.

- v. The Contractor shall keep and maintain professional records of all field surveys and measurements, the related computations and calculations, manuscripts, plans, drawings and maps, and shall make them available to the Engineer whenever requested.
- vi. If in the opinion of the Engineer, deficiencies and/or inaccuracies in field and office work have been found, such work shall be repeated and made good to the satisfaction of the Engineer at the Contractor's expense. The Contractor shall be solely responsible for accuracy of Survey maps and drawings prepared out of the surveys.

3.4.2 Preparatory Works

- i. Prior to starting survey works, the Contractor shall inform his surveyors of the general construction procedure, survey requirements and time limits. The surveyors shall make adequate terrain investigations with respect to sightings, vegetation to be removed, placement of datum points, reference monuments and benchmarks, taking into consideration future construction work which may affect the survey. Based on these investigations, a survey plan shall be developed comprising existing basic data, the survey grid to be developed, the equipment required for the particular survey task. Staff and time requirements arrangement in a way to warrant smooth progress of construction works. The plan shall be submitted to Engineer in charge for approval.
- ii. All survey work shall be done within greatest care and precision.

3.4.3 Verification of Survey Grid

- i. The Contractor shall verify the basic survey grid.
- ii. All coordinates and elevations as shown on the Drawings are based on the basic survey grid. If after having executed the verification, the basic survey grid reveals inconsistencies, which may affect the location, alignment and elevation or structures of the works, the Engineer shall be forthwith informed of these inconsistencies by the Contractor.
- iii. The Contractor shall record all calculations, control surveys, setting out and check surveying in a suitable permanent form for verification, which shall be available to the Engineer on request at all times.

3.4.4 Augmentation of Basic Survey Grid

- i. Existing datum points and benchmark located very near to the permanent structures may be endangered by construction activities. The Contractor shall therefore in due time establish additional datum points at safe locations and elevations to augment or extend the basic grid.
- ii. The new datum points shall be of permanent nature and shall be constructed as, directed by the Engineer.
- iii. The Contractor shall also establish reference monuments for center lines and

line control of structures, which need frequent and extended control surveys for tunnel alignment and connected works.

- iv. New datum points, reference monuments and benchmarks shall be protected and maintained in the same way as the original grid points.

3.4.5 Survey of Ground Profiles

- i. Original Ground Profiles.

The Contractor shall inform the Engineer in writing, at least 14 days before commencing such work, of his intentions to perform any work which will result in a change to the topography of the existing site for the permanent works and or for temporary works. Thereupon, before commencing any work, the Contractor shall survey the original topography with the approval of the Engineer over the entire area to be occupied or disturbed. Such survey may again be required after removal, of vegetation, topsoil or other overburden. The Contractor and the Engineer shall record the information so obtained. The Contractor shall then provide the Engineer with a reproducible copy of each drawing to serve as a permanent record of the purpose of determining the quantities of excavation or earth works carried out in the construction of the permanent structures, such records will also be required to ascertain the extent to which Temporary works shall be removed or temporary excavations shall be refilled upon completion of the works.

- ii. The Contractor shall also survey all excavated and final surfaces for the purpose of recording as constructed details, and for the measurement of quantities. Such survey shall be required at the following two stages:
 - a. On completions of excavation and prior to placing concrete or other work.
 - b. On completion of works.

3.4.6 Setting Out Works

- i. The Contractor shall perform all setting out and check surveying of the Works in accordance with methods approved by the Engineer. The methods and programme of checking shall be such as to ensure the construction of every part of the Work to the correct line and level. The Engineer may at any time ask the Contractor to submit proof that his own setting out has been satisfactorily checked.
- ii. The number of points required for setting out as well as the spacing between these points shall be determined by the Contractor in accordance with the type of work. The Engineer may require that some or all of the given points and datum levels be clearly marked during construction in such a way that the marks can be retained after completion of construction.

3.4.7 Setting Out Checks

- i. Contractor should carry out the Net Survey (Close traverse) regularly at least

once in two months while executing the work of underground excavation and will submit the results to the Engineer to ensure that progress of excavation is correct as per design alignment.

- ii. The Contractor is expected to liaise with the Engineer to program the check survey to be carried out during non-production periods or in parallel to construction activities such that the minimum delay or inconvenience is caused to production works, wherever and whenever possible. The Contractor shall afford the Engineer, every cooperation and assistance in this regard including but not being limited to the provision of survey equipment, drainage, lighting, ventilation and the removal of Contractor's equipment and other obstructions such that they do not interfere with the setting out checks.

3.4.8 Tunnel Alignment and Gradients

- i. The Contractor shall establish and maintain at suitable distances from tunnel portal at least three (03) reference monuments and benchmarks on the extended tunnel axis/alignment, to warrant that control surveys during tunnel construction can always be referred to such reference monuments. They shall be secured by auxiliary fixed points permitting the reconstruction of the reference monuments in case these have suffered any damage during tunnel excavation periods.
- ii. Establishment and control surveys of the tunnel alignment and the gradient shall always be referred to such reference monuments.
- iii. Underground alignment and level survey and control thereof shall be performed by the use of suitable precision instruments preferably of the pulsed laser type of equivalent instruments, and auxiliary equipment. Underground survey equipment and methodology shall be subject to the approval of the Engineer.
- iv. In addition to the regular survey, carried out by the Contractor, if required an independent survey organization engaged by Engineer at his own cost, will perform confirmatory survey of Tunnel alignments. The first confirmatory survey is likely to be performed after the 1st 100 m of tunnel has been excavated, following confirmatory survey will be carried out after every 200m of excavation or as decided by Engineer. The Contractor shall be notified in advance about the date of such confirmatory surveys. The Contractor shall cooperate with such surveyor and provide any assistance as required (including stoppage of work, if required) at no extra cost to employer. In this regard, the Contractor may please note the contents of clause no. 2.4 of chapter 2 under section 5 of the tender document
- v. Contractor should carry out precision gyroscopic measurements (GYROMAT equipment or equivalent) at regular intervals at least every 1 (one) Km progress of the main tunnel and escape tunnel, for accurate high-precision azimuth determination, by specialized agency. A detailed report should be submitted to the Engineer after every gyroscopic verification with

the obtained results.

3.4.9 Accuracies and tolerances

i. Accuracies

Accuracy of survey works shall be within the following tolerances:

Triangulation	
Allowable error of closure	
• Average not to exceed	5 Seconds
• Maximum not to exceed	10 Seconds
Traversing	
Allowable error of closure	10 mm per Kilometer
Allowable error of distance	<i>10 mm per Kilometer</i>
Leveling	
Allowable error for each 1 km measured forward and backward	10 mm
Allowable error of closure	$10 \sqrt{S}$ mm

(Where S is the total distance of leveling expressed in km)

ii. Tolerances

- a. The tolerance given below shall be the maximum permissible deviations from the specified dimensions, levels, alignments, positions etc. as shown on the Drawings of the structures of structural elements.
- b. In addition, at the interfaces with mechanical components, concrete surface be finished flush and shall also meet any additional tolerances required by the mechanical designs or works respectively.
- c. Where the tolerances overlap, the severer tolerance shall apply. Determination of centerlines for alignment of tunnels, access tunnels, galleries, caverns and shafts etc. shall meet the following criteria.

Plan positions of central line	± 30 mm
Elevation	± 10 mm

3.4.10 Subsidiary Monuments and Benchmarks

- i. The Contractor shall erect and establish all necessary additional survey monuments, fix points, benchmarks etc. required for setting out of the work and construction control including determination of coordinates and elevations.

3.4.11 Handing over of Basic Survey Data**i.** General Requirements

- a. Prior to the commencement of the survey works, the Engineer shall hand over to the Contractor all information and data of the verified basic survey grid and benchmarks to which the Contractor's survey work shall refer. Upon handing over, the Contractor shall review this information and data and shall verify the existence of the datum points and benchmarks by field checks. Furthermore, the Contractor shall take responsibility for maintenance and protection of these basic datum points and benchmarks.
- b. Should field checks reveal that points and benchmarks have been damaged, displaced or destroyed, the Contractor shall inform the Engineer of this facts, and the Engineer shall give instructions regarding the re-establishment of such datum points and benchmarks.
- c. Should it become necessary that basic datum point and benchmarks be removed because of foreseeable construction works, the Contractor shall inform the Engineer of the need thereof and obtain approval and instruction for the establishment of new basic datum points and benchmarks and/or auxiliary points.
- d. If, within 2 months upon handing over, inconsistencies within the basic grid or related datum points and benchmarks are detected by the Contractor, he shall inform the Engineer immediately thereof and produce the evidence. The Engineer shall subsequently inform and instruct the Contractor on remedial measures to be taken. Any survey work, setting out or measurement already taken or performed prior to the detection of such inconsistency shall be rechecked and corrected by the Contractor.
- e. Additional basic datum points and benchmarks established by the Contractor for the convenience of this work shall have at least the same quality and durability as those of the existing points and meets the accuracy requirements.

ii. Data and Documentation Available

- a. Existing topographical maps based on the surveys, covering the area of the works can be made available to the Contractor upon request to the Engineer.
- b. Topo mapping of areas for temporary facilities like the Contractor's camp, constructional buildings, construction plant, etc., shall be prepared by the Contractor prior to the construction of such facilities. The Contractor shall also perform surveys works for construction roads and bridges including preparation of maps.

iii. Survey Records and Documentation

- a. The Contractor shall keep records of all survey activities such as sketches, field books, calculations, etc., for the duration of the entire construction period. The Contractor shall upon request of the Engineer put at his disposal all records and documentation or provide copies thereof in format agreed by Engineer. On a monthly basis, the Contractor should submit along with the monthly progress report, a detailed report focused on the performed survey work (excavation profiles, tunnel alignment, traversing, etc) and relevant results. After every round, the Contractor shall submit to the Engineer the excavation profile obtained through Tunnel profiler.

CHAPTER -4**DEWATERING, DRAINAGE, PUMPING AND WATERPROOFING****4.1 GENERAL**

4.1.1 The specifications described herein under relate to the work of dewatering, drainage & pumping and installation of water proofing membrane to be carried out by the Contractor, which shall include supply of all labour, construction plant and materials and performance of all services required to remove service water and natural surface flow or ground water seepage under all conditions including rain and flood water from the working areas on the surface as well as from the underground sites for the construction of various structures covered under the contract.

4.1.2 The Contractor shall design, furnish, build, install, operate, maintain and remove all the temporary dewatering facilities as specified herein or as required by the Engineer.

4.1.3 Minimum buffer stock of one month is required to keep at site for all water proofing membranes, Geo-textiles and other water proofing structures as per agreed works program.

4.2 SUBMITTALS

4.2.1 Within 28 day from the commencement date, the Contractor shall submit, to the Engineer, the detailed design of dewatering system.

4.2.2 This design shall be consistent with the outline description submitted by the Contractor with his bid and shall include the following:

- i. Design assumptions and calculations.
- ii. Layouts of drainage facilities.
- iii. Layout and capacity of pumps and pipes, sumps, drains both open and covered, well points etc. and details of standby dewatering arrangements.
- iv. Any other arrangements or installation, the Contractor may propose for dewatering of the working areas both in open and underground Construction sites.
- v. The dewatering design should include standby emergency pumping arrangement to deal with any kind of water inflow.

4.2.3 At least 28 days prior to the scheduled construction of the particular work, the Contractor shall submit, to the Engineer, full details of the equipment to be installed and all necessary construction details required for dewatering purpose.

4.2.4 The Engineer reserves the right to require any additional information deemed necessary to be included in the submitted documents.

4.2.5 At least 56 days prior to the scheduled installation of water proofing membrane, the Contractor shall submit, to the engineer, full details of:

- i. Certificates of compliance attesting that the materials meet specification requirements.

- ii. Manufacturer's instructions for installation of felt backing and waterproofing membrane, including procedures for preparation, fixing, welding and splicing, flashing etc.
- iii. Manufacturer's and installer's qualifications to include evidence of experience of the manufacturer and the installers, as well as resume of lining installation supervisors.
- iv. Samples as listed hereafter:
 - a. Membrane: One square meter of each type membrane (3 Nos.).
 - b. Protective felt: One square meter of each type of felt (3 Nos.).
 - c. Welded splice: 1 m of welded membrane splice for each type of membrane. (3 Nos.).
 - d. Fixings and fittings: 10 samples from different lots of rondels and nails, 2 samples of sealing flanges for projections passing through the membrane.
- v. Shop drawings showing all necessary installation details for felt and waterproofing membrane, including installation sequence, position of joints, treatment of projections, connection to water stops, connection to waterproofing of structures in open cut, local reinforcements etc.

4.3 GENERAL

4.3.1 Dewatering of the surface as well as the underground Construction sites shall be undertaken by gravity, wherever possible. Where, however, dewatering by gravity is not practical, pumping shall be resorted to after this mode has been approved by the Engineer.

4.3.2 The pumped water carried in pipes or flumes shall be discharged at point sufficiently away from the edge of foundation excavation as directed by the Engineer. Care shall be taken to ensure that there is no seepage and flow of water back to the pit working area.

4.3.3 Power for operating the dewatering system shall be arranged by the Contractor at his own cost. The Contractor shall make his own arrangements to ensure sufficient standby power at his cost to carry on the Works during any interruption of power.

4.3.4 Water proofing membrane

- i. Shall be provided to prevent leakage of groundwater into the tunnel and to protect the final concrete lining against deleterious chemical influences. Waterproofing shall be applied to crown and sidewalls above footing or invert arch level. The waterproofing membrane shall always be located between primary shotcrete lining and the final concrete lining. No membrane waterproofing will be provided for tunnel inverts.
- ii. The waterproofing system shall consist of two layers: the first shall consist of a protective felt fastened to the shotcrete surface; the second layer shall be the

actual waterproofing membrane properly fixed by special means as recommended by the manufacturer.

While the sealing function shall be provided by the membrane, the layer of felt is required to protect the waterproofing membrane against damage from contact with the shotcrete surface, to prevent interlocking between concrete and shotcrete in case of differential movements of primary shotcrete lining and final lining, and to provide a drainage layer allowing to drain off groundwater into the longitudinal lateral drainage pipes, thus preventing a build-up of hydrostatic pressure on the tunnel lining.

4.4 DEWATERING OF UNDERGROUND CONSTRUCTION SITES

4.4.1 General

- i. The Contractor shall perform all works necessary to collect and drain service and infiltrating ground water and flood water entered into the underground construction sites (if any), convey it to main HS/Conduits and lead it out from underground works such as tunnels and shafts. Water pumped or drained out of tunnels shall pass through oil skimmer or other oil separator, then through sedimentation basin or by other means as approved by engineer designed for the maximum expected flow before disposal into natural drain / river to ensure clear water discharge. Construction fencing of 1.8m minimum height or other effective protection shall be installed to prohibit unauthorized persons from trespassing into the area of the sedimentation pond.
- ii. The work shall include, but not be limited to, the following:
 - a. Design and construction of pits and trenches, flood protection walls at the entrance/exit portals of tunnels/shafts
 - b. Design, furnishing, operation and maintenance of dewatering equipment.
 - c. All auxiliary works required for the safe and continuous dewatering of the underground sites.
- iii. The Treatment tank shall have arrangement to segregate the PP fibers from water before disposal into natural drain / River to ensure minimum damage to environment. All such fibers so collected shall not be used back on the project and shall be disposed off safely according to manufacturer's recommendations and engineer's approval.

4.4.2 Requirements and Design

- i. The Contractor shall design and provide a complete dewatering system for all underground construction sites.
- ii. All excavated areas shall be drained off all service and ground water. In order to keep the construction areas free from water, the dewatering systems shall be able to operate at any time during the whole construction period in any part of the works at the required design capacity.

- iii. The Contractor shall provide adequate pumping capacity, including a sufficient number of standby pumping units, to handle all water entering including sudden gush of water / flowing ground water condition/ flood water into any portion of Underground works. These units shall be connected to the dewatering systems in such a way that proper and uninterrupted drainage is guaranteed throughout the entire construction period.
- iv. The Contractor shall make arrangement for sufficient stand-by power at his own cost to carry on the works during any interruption of power. The standby power supply shall undergo weekly trial runs lasting at least 30 minutes. No claims shall be entertained, and contractor shall be answerable for lack of progress on this account.
- v. All components of the system shall always be maintained in ready for service condition and all access to pumps and other equipment shall be kept in good condition under the most adverse conditions.
- vi. The Contractor shall ensure that all drainage water is disposed off without causing interference to his own or other Contractor's operations elsewhere on the site, and that no drainage water runs into adjacent works.
- vii. The dewatering system shall be designed and installed in such a way that modifications and extensions to the system are possible while they are in full operation.
- viii. All the components of the dewatering system shall be installed and operated in accordance with the approved method and the construction time schedule, or approved modification thereof.
- ix. The approval by the Engineer of the dewatering system shall not relieve the Contractor from being fully responsible for the design, construction, operation, maintenance, safety and removal of the facilities provided for the dewatering system and he shall be liable for any damage or delays caused by its failure. The Contractor shall indemnify the “Employer” against claims arising out of any such failure made by a third party.

4.4.3 Materials and Execution

- i. The Contractor shall construct the drainage trench in invert of the tunnel as required at site and approved by the Engineer.
- ii. After the excavated profile has been checked, the ground water which runs or drips into the excavated space shall be diverted into the drainage trench by means of water collectors and pipes for collecting the seepage water from rock surfaces or laggings. Damp surfaces or seepage areas with low volume inflows can be sealed off with a quick setting-sealing compound.
- iii. Special care shall be exercised where excavation passes through material, which is liable to soften or swell when it comes in contact with water. In such locations, water entering the excavated space shall be collected as soon as possible and conveyed away / disposed off in such a way that the water does

not come in contact with such material. Should the Contractor neglect to observe this requirement and a deterioration of the excavated surface of tunnel invert results from water being allowed to flow over or stand upon the sensitive or swelling material, the Engineer may order the removal of the material from affected surface and its replacement with concrete. The Engineer may order installation of additional rock supports in connection with such remedial work at the cost of the Contractor.

- iv. If any water from another portion of the underground works flows into a lower section where concreting is being done, which is likely to be affected by water, all such water shall be diverted past this area in such a way that no damage occurs to the concrete. The length of the affected sections over which water has to be diverted shall be ordered by the Engineer.
- v. The Contractor shall perform regular checking and cleaning of the drawing trench and all dewatering equipment and accessories during the construction period.
- vi. The dewatering facilities shall be kept in operation according to the approved schedule, which shall be related to the progress of the work. No pumps shall be stopped, no pipes, ducts, trenches, etc. shall be taken out of service without the permission of the Engineer.
- vii. Any openings such as pipes, boreholes, ducts, pumps, sumps etc. used for temporary drainage purposes. In any part of the work shall be completely sealed by filling with grout, mortar or concrete when no longer required, unless otherwise directed by the Engineer in writing. The Contractor shall notify the Engineer in writing before any such openings are permanently closed.
- viii. Water proofing membrane (Material)
 - A. Protective Felt
 - a. The protective felt shall be a continuous filament non-woven polypropylene geotextile of uniform thickness and surface texture meeting the requirements listed below.

Property	Specified Value	Standard
Unit weight	500g/m ² min	DIN 854
Thickness at 0.02 bar	3.9 mm min	DIN 53855/3
Thickness at 2.0 bar	1.9 mm min	DIN 53855/3
Tensile strength	1000 N/cm ² min	DIN 53857/2
Extension at break	70 % min	DIN 53857/2

Property	Specified Value	Standard
Extension at 30% of Tensile Strength	20 % min	DIN 53857/2
Permeability in plane at 0.02 bar	5×10^{-1} cm/s min	*
Permeability in plane at 2.00 bar	5×10^{-2} cm/s min	*
Resistance against acid and alkaline solutions (pH 2-13)	Loss of strength 10% max	DIN 53857/2
Resistance to Punching	2000 N	DIN 54307

- B. * Test according to Franzius Institute, Hannover, BRD Waterproofing Membrane
- a. The waterproofing membrane shall be Polyvinyl Chloride (PVC).
 - b. The membrane shall be supplied with a signal layer, i.e. a thin sheeting of different color, bonded to one side, which is intended to facilitate the detection of damages.
 - c. PVC Waterproofing Membrane (poly-vinyl-chloride) will satisfy following specifications:
 - d. Accessories: Fixing material, flashing, reinforcement for expansion joints, sealing flanges and preparation of corners and intersections shall be made as recommended by the manufacturer of the membrane.

Property	Specified Value	Standard
Thickness(mm)	≥ 2.0	EN1894-2
Tensile strength at break(N/mm^2)	≥ 17	EN12311-2
Elongation at break (%)	$\geq 300\%$	
Resistance to tearing (N/mm)	≥ 100	EN12310-2
Puncture static test (kN)	≥ 2.5	ENISO12236
Water tightness (B method– 24hours at $0.5 \text{N}/\text{mm}^2$)	Watertight	EN1982

Property	Specified Value	Standard
Change of dimensioning after heating at +70°C for 2 hours	Stable	EN1110
Cold bending (°C)	≥-35	EN495/5
Resistance to acidic and alkaline at 28 days	20% maximum elongation.	DIN16726
Resistance of joints (N/mm ²)	≥10.5	EN12317-2
Fire reaction classification	Class E	EN13501-1

C. Waterproofing Membrane (Installation)

D. Surface Preparation

- a. All surfaces to which waterproofing is to be applied shall be sufficiently clean, smooth and free from deleterious materials and projections.
- b. The following treatment of surfaces shall be performed prior to the installation of waterproofing:
 1. For the fixing of the protective felt and the waterproofing membrane, a minimum shotcrete cover of 50 mm to rock is required.
 2. Irregularities of the shotcrete lining surface shall be eliminated by means of additional shotcrete. The ratio of the diameter to depth of irregularities shall be not less than 5:1. Rounding at rock bolts (where applicable), etc. shall have a min. radius "ra" of 0.3 m. Details are given in Figure below.
 3. Transitions and intersections of tunnel profiles shall be rounded off with a minimum radius of 500 mm.
 4. Protruding steel bars, wires, spacers, pipes etc. shall be cut off unless treated with additional shotcrete cover.
 5. Exposed steel parts such as rock bolts, if not intended to remain accessible, shall be covered with shotcrete.
 6. If required, as per the instruction of the Engineer shotcrete surface shall finally be smoothed with fine-graded shotcrete (rounded aggregates, grain size 0 - 4 mm), applied in a layer of 30 mm average thickness.

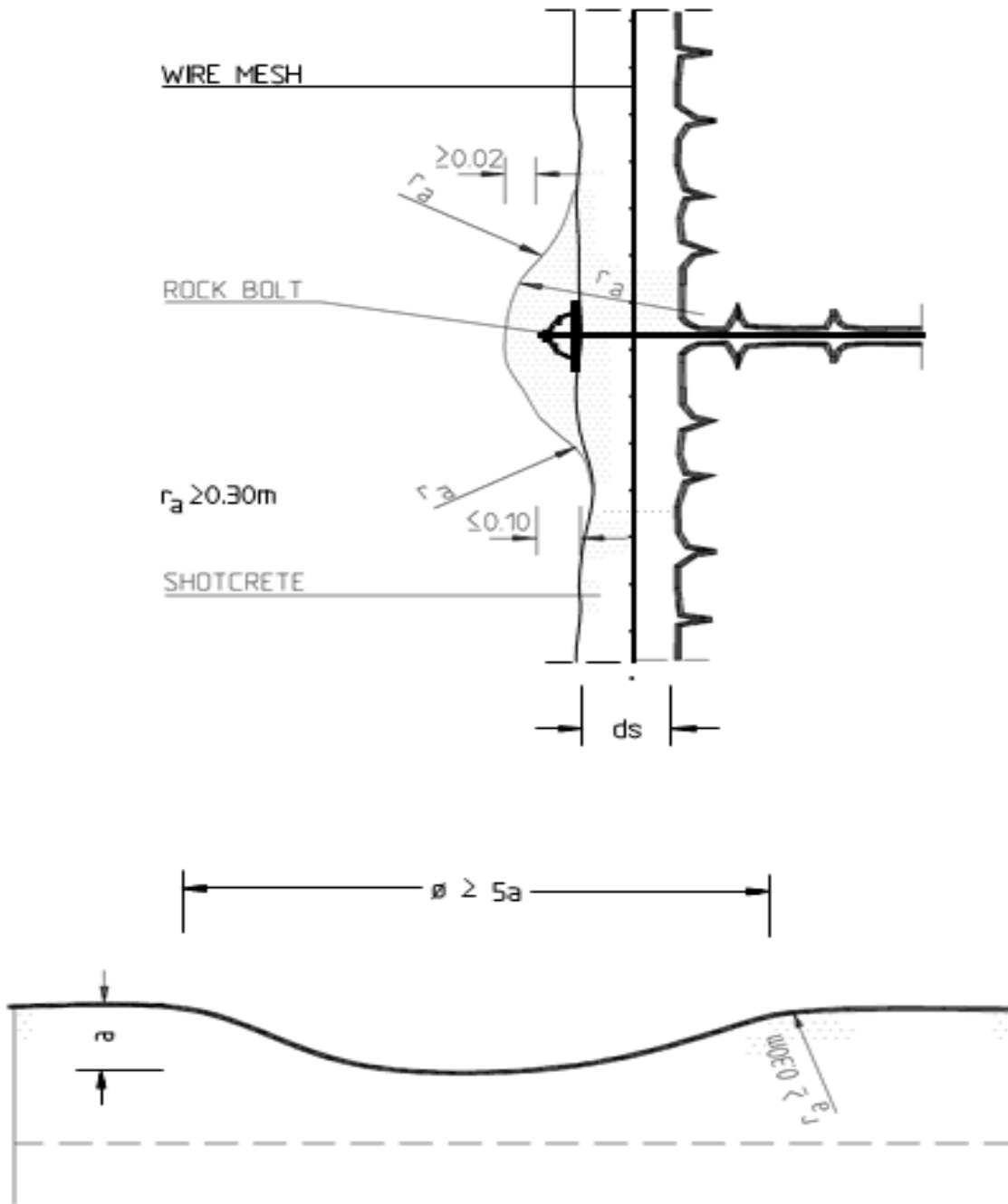

Figure 1: Requirements on surface irregularities of shotcrete

E. Application

- a. General: Prior to the application of the waterproofing, all surfaces to which it shall be applied, shall be inspected and approved by the ENGINEER. The application shall follow the written instructions of the manufacturer. Special preparations will be required for waterproofing at tunnel intersections and for projections passing through the membrane. They shall be carried out according to the manufacturer's recommendation.
- b. Fixing of Felt: The protective felt shall be attached to the shotcrete surface using suitable fixings specified by the manufacturer.

Depending on the location 2 to 4 nos. fixing elements shall be used per square meter. The felt shall be laid with enough slack to avoid overstress during concreting. Adjacent sections of felt shall be overlapped by 100 mm and joined by point welding or similar suitable method. Along the bottom of the tunnel side walls the felt shall extend sufficiently to cover the lateral drainages as shown on the drawings.

- c. **Fixing of Waterproofing Membrane:** The waterproofing membrane shall be installed to cover the felt and shall be attached to the felt fixings and to each other and to the washers by means of thermal welding. No perforation of the membrane shall be allowed for installation purposes. The waterproofing membrane shall be laid with the signal layer towards the inside and with enough slack to prevent overstressing during concreting. Adjacent sheets of waterproofing shall be joined by a double weld. Along the bottom of the tunnel side walls the membrane shall extend sufficiently to cover the lateral drainages as shown on the drawings. Connections to water stops and to the waterproofing of structures in open cuts shall be carried out according to drawings to be furnished by the supplier.

F. Testing of seams

- a. **General:** All seams shall be tested, and records of these tests shall be submitted by the Contractor to the ENGINEER.
- b. **Seam Test with Compressed Air:** For seams between adjacent sheets of waterproofing membrane the testing for tightness shall be carried out by means of compressed air pumped into the test channel which is formed by the double welded joint. Initial test pressure shall be 2 bar for a test period of 5 minutes or 1.5 bar for a test period of 10 minutes. The joint shall be considered waterproof if the loss of air pressure is in both cases not more than 20%.
- c. **Seam Test with Vacuum Equipment:** For the testing of areas of membrane of limited size such as special configurations of joints or local repairs with patches, vacuum equipment shall be employed, as instructed by the ENGINEER. This equipment consists of a vacuum bell which, after being fitted tightly over the area to be tested, is evacuated by pumping in order to detect leaks in the membrane.
- d. **Protective Measures:** Every care shall be taken not to damage the waterproofing membrane during or after installation. Any damages occurred shall be repaired and tested before the casting of the final concrete lining.

4.4.4 WATER STOPPER

- i. Polyvinyl Chloride (PVC)/ rubber water stops shall be furnished and installed for watertight construction at various locations of concrete structures / components covered under these specifications. In order to ensure proper alignment and fixing of water stops in correct position / place, the same shall be rigidly secured to the form work or reinforcement steel as direct/approved by the ENGINEER.
- Number of joints in PVC/rubber water stops, when installed in place shall be the barest minimum and joints, thus made, shall be suitably vulcanized/welded using best method/Engineering practice satisfactory to the ENGINEER.
- ii. All types of water stops shall be tested in a recognized laboratory prior to transport to the site. Test specimens shall be furnished by the manufacturer and the tests shall be carried out at the manufacturer's place.
- iii. Water stops shall be tested as to their tensile strength, elongation, duration, water absorption, specific gravity, effect of alkali and impact resistance. The PVC Water stops shall meet the following requirements:
- iv. The Contractors shall submit to the ENGINEER for approval the test results from recognized institution showing that the material supplied meets the requirements specified. The ENGINEER may carry out the additional tests, for which the Contractor shall supply specimens from the same material to be used in the work. Test specimens, if required shall be of the shape and dimensions as required in the individual test methods.

Requirement	Method of Test
Tensile strength using die "C" not less than 150	ASTM D-412
Ultimate elongation using die "C" not less than 330%	ASTM D-412
Stiffness in flexure, 6 mm span: not less than 28	ASTM D-747
Tear resistance: not less than 30 kgf/cm ²	ASTM D-624
Specific Gravity: not less than 1.20	ASTM D-792
Shore Hardness: 60A to 80A	
Water Absorption: not more than 5% in a 7 days test	

- v. Precautions for Water stopper:
- a. PVC water stops will be provided according to drawings in transversal and longitudinal positions at all along the lining tunnel extension. These bands must be welded (heat or vulcanization) among them at the intersection points. For the fault areas, an Omega PVC band will be affixed to the waterproofing membrane. The geometry and type of these water stop bands and Omega band are defined in specific project drawings. To weld the ends of the water, stop bands in transversal joints or in the intersections between transversal and longitudinal water stops

bands the parts that must be vulcanized have to be prepared. It is responsibility of the Contractor the preparation and the vulcanization of the water stops unions.

- b. When delivered to site, the water stop products must be unloaded carefully and inspected immediately for completeness and integrity, including form and dimensions. Before installation the water stops must be kept in a sheltered place on boards or some other firm base (e.g. pallets, concrete surfaces) and protected from contamination or damage.
 - c. Water stops must be protected from direct sunlight, especially in summer, e.g. by covering. In high outside temperatures water stops must be taken to the point of installation and laid out under no tension.
 - d. Water stops should be kept in covered storage if possible and then be put in heated rooms for at least one full day prior to their installation, to make their handling and installation easier and less prone to damage (thermoplastic material).
- vi. Installation of water stopper
- a. Fixing Internal Water stops: Internal water stops are anchored to the reinforcement. The water stops are fixed to the edge anchors with the special waterstop clip or, in the case of waterstops with steel plates (FMS, FS) to the edge perforation of the steel plates at maximum intervals of 25 cm.
 - b. Spacing Between Joints in the waterstops Themselves: The spacing between two joins in the waterstops themselves should be 0.50 m minimum. In every configuration the length of the free waterstop ends should be 1.00 m minimum so that these connection joints can be formed easily and correctly on site.
 - c. Embedding of External Waterstops: Waterstops must be free from contamination and ice when casted in. If necessary, they should be cleaned before concreting (e.g. removal of any accumulated site debris such as sawdust, sand, concrete residues, cement laitance, oil, grease, snow, ice etc.). This is particularly important for external waterstops in the base of a structure.
 - d. Clearance between Poker Vibrators and Waterstops: The poker vibrators must never touch the waterstop or its fixings (minimum clearance ≥ 10 cm). It is usually preferable to compact around external waterstops with external vibrators, which will also give better compaction around stop end anchors.
 - e. Protection of Exposed Waterstops on Site: The waterstops should be protected from damage until they are fully casted in.

4.4.5 Permanent Groundwater Drainage

i. General

- a. This Chapter applies to the installation of the permanent groundwater drainage system in the tunnel.
- b. This Chapter covers the requirements for the permanent groundwater drainage system inside the tunnel.
- c. The drained groundwater will flow from the highpoint of the tunnel alignment to Main tunnels.
- d. The permanent groundwater drainage of the tunnel shall consist of a main collector pipe along the entire length tunnel and lateral drainage pipe(perforated) with transversal connection pipes to the main collector pipe at regular interval along tunnel sections where major water inflow occurs. The decision of the groundwater drainage system to be installed along a certain tunnel section will be made by the ENGINEER.
- e. Drainage gutters shall be located along the entire length of the tunnel at the bottom of either tunnel side wall for collecting groundwater possibly entering through the tunnel lining. The water shall be diverted into the main collector pipe by means of transversal connection pipes.
- f. Along tunnel sections with lateral drainage pipes and without invert arch, perforated pipe will be installed at the bottom of the tunnel as invert drainage.
- g. At the intersections of the main collector pipe with the transversal connection pipes maintenance manholes shall be installed. Manholes shall also be installed for the maintenance of the invert drainage.

ii. Materials

- a. The lateral drainage pipes shall consist of circumferentially slotted, PVC pipes with a minimum diameter of 200 mm as shown on the drawings. The slots shall be within the corrugated area. The width of slots shall not exceed 1.0 mm. The total area of the slots for water intake shall be more than 100 cm² per metre length of pipe.
- b. The main collector pipe in the main and escape tunnels shall be virgin HDPE pipes as per design drawings. The HDPE pipe shall be conforming to I.S. 4984/ 4151 / 12786/ 13488 with necessary jointing material like mechanical connectors i.e. thread / insert joint / quick release coupler joint / compression fitting joint or flanged joint
- c. The transversal connection pipes shall be PVC pipes with a minimum diameter of 150 mm.
- d. The cleaning access pipes shall be PVC pipes with a minimum diameter of 150 mm.
- e. No-fines porous concrete shall be used for embedment of the lateral drainage pipes and of the invert drainage pipe. No-fines porous concrete

shall also be installed at the bottom of Regular Tunnel Cross Section Type as shown on the respective drawing. No-fines porous concrete shall be composed of ordinary Portland cement and single-sized aggregate of nominal size of 40 mm according to IS 383 (with a maximum grain size of 40 mm). The ratio of aggregate to cement shall be 8:1 by volume or 10:1 by mass.

- f.** Maintenance manholes as well as the drainage gutters shall be made of concrete grade M30 according to IS 456: 2000. (Reaffirmed 2011)
- g.** Inspection shafts that will be installed in the ballast less track of the Main Tunnel shall be constructed in accordance to the requirements of the BLT design and approved by the BLT engineer.

iii. Execution

- a.** The water appearing and/or collected during construction behind the waterproofing membrane shall be diverted permanently into the lateral drainage pipes installed at the bottom of each sidewall of the tunnel.
- b.** The lateral drainage pipes shall be covered and protected by no-fines porous concrete.
- c.** Inspection chamber shall be installed in the inner concrete lining for permanent maintenance (flushing) of the lateral drainage pipes as shown on the drawings.
- d.** The Contractor shall ensure that the permanent ground water drainage system is used only for the control of groundwater. Throughout the construction regular inspection and servicing shall be provided.
- e.** The Contractor shall protect and maintain the permanent ground water drainage system during construction phase so as not to compromise the effectiveness of the system during operation.
- f.** All pipes for control of the ground water shall be installed to line and grade as shown on the drawings.
- g.** No-fines porous concrete shall be mixed by machine or by hand to a uniform colour and consistency before placing. The quantity of water used shall not exceed that required to coat all of the aggregate particles without forming excess grout. The no-fines porous concrete shall be compacted by hand only.

CHAPTER -5**DEWATERING OF SURFACE CONSTRUCTION SITES****5.1 DEWATERING OF SURFACE CONSTRUCTION SITES****5.1.1 General**

- i. The Contractor shall perform all works necessary to drain the surface construction sites of rain, flood water, ground water and service water. The Work shall include, but not be limited to the following:
 - a. Design and construction of drainage, ditches, pits, dykes/bunds and pump sumps.
 - b. Design, furnishing, operation and maintenance of dewatering equipment.
 - c. Relocation of dewatering facilities required for the performance of other Works.
 - d. All auxiliary Works required for safe and continuous dewatering of the construction sites.
- ii. Dewatering of surface construction Sites located near and above a river/stream shall be done up to the existing water level in the river / stream by gravity as directed by the Engineer. Suitable drainage shall be made joining the course downstream of the construction Site to provide required gradient to facilitate proper and efficient dewatering. Below the water level of the stream, dewatering shall be done by pumping water collected in the sumps and discharging the same into course of the river/stream downstream of the construction Site.

5.1.2 Requirements and Design

- i. The Contractor shall design and install complete facilities at the surface construction Sites.
- ii. The surface water dewatering systems shall be designed to accommodate, without undue disruption to the work, any rainfall event and considering the extent of the Sites to be dewatered and the dewatering arrangements proposed.
- iii. Claims for extension of time due to delays caused by unfavorable weather conditions will not be considered.
- iv. The Contractor shall provide adequate pumping capacity, including standby units, to handle all water entering any of surface construction Sites. In addition, he shall provide sumps and pumps and or well points in the immediate vicinity of the structure foundations using such water conductors as are necessary to conduct the water away from the excavation and concrete placement operations in an approved manner, so that such operation shall be kept free from standing or running water.

- v. Power for operating the dewatering system shall be arranged by the Contractor from existing poling points. The Contractor shall also make his own arrangement for enough standby power at his own cost to carry out the works during any interruption of power.
- vi. The Contractor shall ensure that all drainage water is disposed off without causing interference to his own or other Contractors' operations elsewhere on the Site and that no drainage water runs into adjacent Works.
- vii. The dewatering systems shall be designed and installed in such a way that modifications and extensions to the systems are possible while they are in full operation.
- viii. All the components of the dewatering systems shall be installed and operated in accordance with the approved method and the construction time schedule, or approved modification thereof.
- ix. The approval by the Engineer of the dewatering system shall not relieve the Contractor from being fully responsible for the design, construction, operation, maintenance, safety and removal of the facilities provided for the dewatering system and he shall be liable for any damage or delays caused by its failure. The Contractor shall indemnify the Employer against claims arising out of any such, failure made by a third party.

5.1.3 Materials and Execution

- i. Catch water drains shall be excavated along the top of excavated slopes and on the berms. Such drains shall be kept well back from the excavation edges in order to prevent saturating the upper part of the slopes. The drains shall be regularly cleaned out of all accumulated silt and other matter so that water may always flow freely .
- ii. Where excavation is to be made below the ground water table, the Contractor shall lower the water table sufficiently below any working surface by means of properly screened wells and/or ditches to ensure that the foundation surfaces remain free of standing water and undamaged by the passage of construction traffic. All drains shall be outside the foundation areas. The water shall be collected and removed by pumping, if no outflow by gravity is possible.
- iii. Where concrete is to be placed, the water table shall be maintained below the lowest part of the finished excavation for minimum one day following the raising of structure above the natural ground water table, and for such additional time as may be necessary to preclude damages to structure foundation.
- iv. In trenches and foundations, the dewatering shall always enable to carry out the excavation Work in dry, and in a manner that will prevent loss of fines from the foundation.

- v. Upon completion of dewatering, temporary pipes and pump sumps beneath permanent structures shall be closed off and filled with grout, mortar or concrete as required by the Engineer.

CHAPTER -6

EXPLOSIVE AND BLASTING

6.1 GENERAL

- 6.1.1** The Specifications described herein under relate to supply transportation, handling, storage and use of explosives. All operations shall be carried out by the Contractor as per Indian Explosive Act, statutory requirements and regulations as applicable in India.
- 6.1.2** Contractor may obtain license from statutory authority for procuring, transporting, storing and using explosives. The same may also be arranged through existing approved suppliers/license holders in the project area. The Contractor may also have his own magazine for the storage of explosives etc. In either case, no claim from the Contractor will be admissible on account of any delay in obtaining any mandatory permissions or in arranging the same for progress of the work.
- 6.1.3** The Contractor will be required to draw the explosives, transport to the site and keep it safely as per safety guidelines of Indian Explosive Act. He shall acquaint himself with all applicable latest laws and regulations concerning storing handling, safety and use of explosives. The Engineer may issue modifications, if required, and the Contractor shall comply with the same without these being made a cause for claim whatsoever, against "EMPLOYER".
- 6.1.4** Word "Explosives" would also mean the accessories related I similar substances for the purpose of safety unless otherwise specified.

6.2 SUBMITTALS

- 6.2.1** At least 56 days prior to the commencement of the excavation works, the Contractor shall submit to the Engineer for approval, the details relating to transportation, storage and use of materials such as explosives, detonators, Detonating I safety fuse coils, Blasting Cables, Exploders, Loading Poles and tamping materials etc.
- 6.2.2** The Engineer reserves the right to require any additional information deemed necessary to be included in the submitted documents.

6.3 STANDARDS

- 6.3.1** Transportation, handling, storage and use of explosives shall be carried out under Indian explosive regulation, 1984 in a safe and efficient manner and shall also conform to the following Indian Standards or where not covered by these Standards, to equivalent International Standards.

Indian Explosive Act 1883 and Explosives regulations 1984 (Amended 2005)

IS 4081 Safety code for blasting and related drilling operation underground excavation in rock.

IS 6609 Methods of test for commercial blasting explosives and accessories.

IS 10081 Terms relating to commercial explosives, Pyrotechnics and blasting practices.

IS 15447(Part-I) Commercial blasting explosives specification- Nitroglycerin based.

IS 4863 Glossary of mining terms (drilling and blasting)

IS 7526 Detonating fumes.

IS 7632 detonators.

IS 5878(Part-II/Sec. I) Code of Practice for construction of tunnels

6.3.2 In case of conflict between the above standards and the Specifications given herein the specifications shall take precedence.

6.4 SUPERVISION

6.4.1 Before taking up blasting operation, contractor/Explosive manufacturer shall submit face wise blast pattern covering blasting pattern, minimum safe charge, vibration control / monitoring etc. for various class of rock mass likely to encounter during excavation to be approved by Engineer/institute of repute as approved by Engineer. Such study report shall have to be got updated improved periodically during the excavation period.

6.4.2 Design and excavation by blasting shall be permitted only under the supervision of competent and trained workmen who are fully experienced in the work and who have received adequate instructions. The Contractor shall make sure that his blasting crew is fully conversant with the rules and regulations concerning storing handling and use of explosives. *The design of blasting and vibration monitoring shall be got approved from CIMFR Dhanbad by the Contractor at his cost before submitting to the Engineer for approval. Initial blasting in rock shall be supervised by officials of CIMFR. Blasting near portal P1 shall also be supervised by officials of CIMFR. All expenditures incurred on the visit of officials of CIMFR shall be borne by the Contractor.*

6.4.3 Blasting specifications should include detailed description of state-of-the-art detonators, explosives and blasting patterns as well as blasting expert services including training of actual site personnel to be provided on site at the start of the project.

6.5 TRANSPORTATION AND HANDLING

6.5.1 Explosive shall not be transported to the Site of operation except in suitable cases or containers, which are so made as to prevent any spillage of explosives during conveyance. No explosive shall be removed from such cases or containers except when it is to be used forthwith for the purpose of the work.

6.5.2 Suitable Explosive Vans, duly approved by the Engineer, shall be used for transportation of explosives and detonators. The following rules shall be observed for use of Explosive Van:

- i. Vehicles shall have springs under the body. Tyre pressures shall be as per Indian Explosives Regulations.
- ii. Detonators and igniters shall not be carried in the same vehicle with explosives.

- iii. Beside the driver, only one helper shall be accommodated in the Explosive Van. The vehicle carrying the explosives shall not be used to transport workmen or other materials to workshops although there may be enough space for men or materials.
- iv. Driver shall not leave the vehicle unattended while transporting explosives.
- v. All vehicles transporting explosives shall be marked or placarded on both sides and with the word "EXPLOSIVES" in bold letters. All explosive boxes shall bear explosive's Batch details, Mfg. Date and specifications etc. clearly on them.
- vi. A motor vehicle carrying explosive shall not be refueled except in emergencies and that too only when motor is stopped, and other precautions taken to prevent accidents. Such vehicles shall invariably have at least two fire extinguishers placed at convenient points.
- vii. Use of Mobile phones shall be restricted while carrying detonators or while refueling takes place.
- viii. Explosives Vehicle should have the seat belt for driver and the use shall be mandatory for the driver.
- ix. Vehicles transporting explosives shall never be taken into a garage, repair shop parked in congested areas, or in a public garage or similar building.
- x. Explosives shall not be transported on a public highway during hours of darkness except in extreme emergency and that too only with the written approval of the Engineer.
- xi. Explosives shall not be transported in any form of trailer, nor shall any trailer be attached to a motor truck or vehicle hauling explosives.
- xii. No transfer of explosives from one vehicle to another shall be made on any highway except in case of emergency.
- xiii. Persons employed in the transport or handling of explosives shall not carry with them or in the vehicles, matches, loaded firearms, petrol or any flame-producing devices.
- xiv. All explosives shall be adequately protected against theft.
- xv. Smoking shall be prohibited during handling, transportation and use of explosives. The places of Explosives storage shall be clearly marked as "No Smoking".
- xvi. The speed of the vehicle shall not exceed 25 km per hour on rough roads and 40 km per hour elsewhere.
- xvii. The interior of the body of the vehicle shall not have any exposed metal parts except those of copper, brass and other non-Sparking metals and shall be preferably lined with wood.

6.5.3 Motor vehicles used for transporting shall be carefully inspected daily to ensure that:

- i. No petrol driven vehicle shall be used.
- ii. Filled and serviceable extinguished are in position.
- iii. The electric wiring is well insulated and firmly secured.
- iv. Chassis, engine and body are clean and free from surplus oil and grease.
- v. Fuel tank and feed lines are not leaking.
- vi. Lights, brakes and steering mechanism are in good working order
- vii. Vehicle is in proper condition in all respects for the safe transportation of explosives.
- viii. Two nos of red flags shall be present at the left and right top front ends of the vehicle
- ix. Condition of Van doors and locking arrangement shall be checked to ensure that rainwater or moisture doesn't damage the explosives case.

- 6.5.4** Boxes or explosives shall not be handled roughly or allowed to fall.
- 6.5.5** Containers of explosives shall be opened only by means of non-sparking tools or instruments.
- 6.5.6** After the loading of a blast is completed, all excess explosives and detonators shall be removed to a safe location or returned at once to the storage magazine, observing the same rules as when being conveyed to the blasting areas.
- 6.5.7** Containers for detonators shall always be used for storing detonators only.
- 6.5.8** Explosives and detonators shall be carried in separate containers and by separate persons to the loading face. Only non-electric detonators shall be used.
- 6.5.9** The drivers of the vehicle carrying explosives shall be trained in use of fire extinguishers on his vehicle.
- 6.5.10** If any fire occurs on a vehicle carrying explosives the driver shall take all practicable steps to ensure that all other traffic is stopped at least 300 m from the vehicle and that all persons in the vicinity are warned of the danger.
- 6.5.11** Loadings, unloading and handling of explosives shall, be supervised by qualified personnel. At the time of loading or unloading of explosives no electric switch shall be operated.
- 6.5.12** Explosives shall not be placed where these may be exposed to flame, excessive heat sparks or impact or hazards of similar nature.
- 6.5.13** The covers of the explosives cases or packages shall be replaced every time after taking out part of the contents as long as any explosives are left in them.
- 6.5.14** Explosives shall not be carried in any way other than as specified in The Explosives Act & The Explosives Rules.
- 6.5.15** Contractor shall ensure no misuse or mishandling of explosives such as carrying the explosives material in the pockets or folds of clothing etc. by any person.

- 6.5.16** Primers shall not be made up in advance. Priming shall be carried out only when charging of the face starts except emergency for which written approval from Engineer shall be required.
- 6.5.17** Nothing shall be inserted in the open end of a blasting cap except fuses.
- 6.5.18** No person shall strike, tamper with, or attempt to remove or investigate the contents of a blasting cap or an electric blasting cap or attempt to pullout the crimped safety fuse out of a blasting cap.
- 6.5.19** No attempt shall be made to soften the explosives by any specific treatment such as heating over a fire or by rolling the explosive on the ground.
- 6.5.20** The blasting powder, explosives, detonators, fuses, etc. shall be in good condition and not damaged due to damp moisture or any other cause. They shall be inspected before use and damaged articles shall be discarded totally and removed immediately.
- 6.5.21** No attempt shall be made to reclaim or use fuses, blasting caps, electric blasting caps or any other explosives, which have been water, soaked, even if these have been dried out. The manufacturers shall be consulted for this.
- 6.5.22** The Contractor shall make all necessary arrangements for the security of the explosives during transportation. However, the Engineer, upon a request by the Contractor, may arrange protection by the Govt. security forces for large quantities of explosives, and the corresponding cost shall be borne by the Contractor.

6.6 STORAGE

- 6.6.1** The Contractor may either obtain necessary licenses and consents and provide secure storage facilities for all explosives and equipment in accordance with Indian explosive act and requirements of local administration and engineer or may arrange explosives from *any* existing explosive supplier in the region. In either case, the Contractor shall take approval of engineer and keep him initiated of the source of explosives. No claims on account of any delays will be admissible in this regard.
- 6.6.2** If the Contractor has arranged the required licenses and decided to establish his own magazine for the storage of explosive etc. then: -
- i.** The Contractor will be required to draw the explosives, transport to the site and keep it safety as per safety guidelines of Indian Explosive Act and the Explosive Rules. The magazine shall always, be kept scrupulously clean.
 - ii.** All the explosives like dynamite shall be stored in a dry clean, well ventilated and fireproof building' constructed in accordance with Indian Explosives Act, on an isolated Site. The area around the magazine for 8 m shall be kept clear of all vegetation and combustible matter.
 - iii.** There shall be a barbed wire fencing and security lights around the magazine and security guards shall be posted around for 24 hours to prevent loss or theft of explosives.
 - iv.** Explosives, detonators and fuse coils shall be stored separately.

- v. The Contractor shall maintain a record of storage and withdrawal of all explosives. This record shall be made available to the Engineer on request. The Engineer shall be promptly notified of any loss or theft of explosives.
- vi. Explosives shall be stored and used chronologically to ensure that the ones received earlier are used first. There shall be enough space between the stacks.
- vii. A "preparation area" shall be identified close to the charging face prior to every blast for preparatory work by experienced men as required for the work. All safety measures shall be ensured in the "preparation area".
- viii. Unauthorized persons shall not be allowed at any time to enter the magazine.
- ix. The person-in-Charge of the magazine shall, always, ensure that the magazine is securely locked.
- x. Explosives shall be handled and used only by the Contractor's duly authorized personnel. The names and qualifications of such personnel shall be submitted to the Engineer in writing in advance of any possible use of explosives.
- xi. The magazine on no account is to be opened during or on the approach of a thunderstorm and no person shall remain in the vicinity of the magazine during such storm. Enough lightning conductors shall be provided on top of the magazine.
- xii. Magazine shoes, without nails, shall always be kept in the magazine, and a wood tub or cement trough, about 30 cms high and 45 cms in diameter filled with water shall be fixed near the doors of the magazine.
- xiii. Persons entering the magazine shall put on the magazine shoes provided for the purpose and be careful not to allow the magazine shoes to touch the ground outside the clean floor.
- xiv. Persons with bare feet shall before entering the magazine, dip their feet in water, and then step direct from the tub over the barrier (if there is one) on to the clean floor.
- xv. A brush or broom shall be kept in the lobby of the magazine for cleaning the magazine on each occasion it is opened for the receipt, delivery or inspection of explosives.
- xvi. No matches shall be allowed in a magazine.
- xvii. No person having articles of steel or iron on him shall be allowed to enter a magazine.
- xviii. Oily cotton rags, cotton waste and articles liable to spontaneous ignition, shall not be taken into a magazine.

- xix.** No tools or implements other than those of copper, brass, gun metal or wood shall be allowed inside the magazine. Tools shall only be used with great gentleness and care.
- xx.** Boxes of explosives shall not be thrown down or dragged along the floor and shall be stacked on wooden trestles. Where there are white ants, the legs of the trestles shall rest in shallow, copper, lead or brass bowls, containing water.
- xxi.** Package containing explosives shall not be allowed to remain in the sun.
- xxii.** Empty boxes shall not be stored in the magazine nor let any packing material lie loose.
- xxiii.** Blasting caps and electric blasting caps shall never be stored in the same box, magazine or building with other explosives.
- xxiv.** The following shall be hung in the lobby of the magazine:
 - a. A copy of these rules;
 - b. Display of Magazine License No and the capacity
 - c. A statement showing the stock in the magazine and
 - d. Certificate showing the last date of testing of the conductor
- xxv.** Adequate firefighting equipment shall be provided in the magazine.
- xxvi.** Signboards reading “DANGER HIGH EXPLOSIVES” “PROTECTED AREA” “NO SMOKING etc. shall be conspicuously displayed in front of the magazine.
- xxvii.** No explosives shall be stored in the tunnel and adit except for the purpose of charging for an immediate blast. Such storage shall be close to the face and for the quantity limited to the immediate blast requirement. Primed cartridges shall be seated by even steady pressure only.

6.7 DISPOSAL OF DETERIORATED EXPLOSIVES

- 6.7.1** All deteriorated explosives shall be disposed off in an approved manner as per Explosive Regulation- 1984, The quantity of deteriorated explosives to be disposed off, shall be intimated to the Engineer prior to its disposal.

6.8 DRILLING

- 6.8.1** Preferably, Boomer automation software shall be used to finalize drill pattern, hole orientation, termination depth, sequence etc. The boomer shall be total station navigated before drilling holes. All holes should end at same depth. Manual mode shall not be resorted to. A report of the drill hole data (Measured while drilling) along with drilling report shall be generated and handed over to engineer after the drilling. Without affecting drilling quality, Engineer may allow other methods to finalize and execute drill pattern with permission of employer.
- 6.8.2** The holes shall be drilled in automatic mode preferably, so that drilling accuracy is guaranteed. Drill pattern and drilling sequence created on PC through supported

software shall be transferred to the drilling rig for this purpose. Without affecting drilling quality, Engineer may allow other methods for drilling of holes with permission of employer.

- 6.8.3** Preferably parallel cut drilling pattern shall be adopted. The perimeter holes shall be located within 0.10m deviation from approved blasting plan and never within the design line of excavation. Lookout angle for perimeter holes shall not exceed 2° and drilling deviation of shall not exceed 5% of the borehole depth to a maximum of 250mm at the end of hole. Engineer, with permission of employer, may allow other type of cuts which do not increase the blast damage zone compared to specified type of cut.
- 6.8.4** All holes shall be of greater diameter than the diameter of the cartridges of explosives used.
- 6.8.5** Perimeter boreholes shall not be more than 0.6m apart. Distance between perimeter and next row of boreholes shall not be more than 0.9m, unless adoption of greater distance does not harm the rock outside design perimeter.
- 6.8.6** Loading and drilling shall not be carried out with Electric detonators in the same tunnel simultaneously.
- 6.8.7** Under no circumstances shall any holes be charged until completion of all drilling operations at the face.
- 6.8.8** A drill or pole shall not be inserted in sockets of old holes even its examination fails to disclose explosives.
- 6.8.9** Drilling shall not be resumed after-blasts had been fired until a thorough examination has been made to make sure that there are no misfires and sockets with explosives which the drills may strike.
- 6.8.10** Drilling shall not be started until all remaining sockets of old holes are examined for unexploded charges.
- 6.8.11** Drilling crew shall be provided with approved respirators in siliceous dusty atmosphere arising out of drilling operations.
- 6.8.12** Blast design should cater to the changes in geology and/or geotechnical parameters for each face and shall be decided face wise on ground

6.9 LOADING AND CHARGING

- 6.9.1** The holes shall be cleared of all debris before a cartridge is inserted.
- 6.9.2** In loading the holes, tamping, if required shall be done with a wooden mallet having no exposed metal parts.
- 6.9.3** Primed cartridges shall be first inserted and shall be seated by even steady pressure only.
- 6.9.4** All loaded holes or charges shall be checked and located before firing.
- 6.9.5** When holes are sprung ample time shall be left between spring shots for the hole to cool, and between the last springing shot and the loading of the main charge.

- 6.9.6** When practicable, no more cartridges shall be primed those are required for a round of blasting.
- 6.9.7** Detonators shall be inserted at the end of the primary cartridge facing the end of the drill hole, which is prepared specially for the purpose.
- 6.9.8** Holes in cartridges for inserting the detonator shall be made with a sharpened wooden stick.
- 6.9.9** When blasting on the surface the entire area to be blasted must be covered with blasting mats, in locations where surface structures are to be protected, from damage by flying rock fragments.
- 6.9.10** Detonating cord shall be cut from supply reel before attaching to explosive or tamping in hole. Use of the short pieces of fuse shall be prohibited for detonation purposes.
- 6.9.11** No welding shall be done inside the tunnel / cavity at the time or loading or charging of the face, till the blast has been taken.
- 6.9.12** Naked flames and lamps shall be kept away at the time of the loading of holes.
- 6.9.13** Before starting the charging/loading of holes all electrical lines must be disconnected.
- 6.9.14** Contractor shall arrange visits of Explosive manufacturer's technical team to design and execute the blast, train the blasting crew and supervise the blasting crew as per the direction of the Engineer.
- 6.9.15** A team from explosive manufacturer shall be arranged by contractor to remain at site until the definitive drilling patterns/blast plans are defined for each support class.

6.10 TYPE OF EXPLOSIVES & ACCESSORIES

6.10.1 Explosives

- i. For enhancing safety of operations, saving in time and better control of blast quality, bulk type explosives shall be preferable.** However, packaged explosives may also be used.
- ii. Explosives shall meet following criterion: -**

S.No.	Parameter	Packages Explosive	Bulk Explosive
1.	Density of explosive	1.15±0.05 g/cc	0.6-1.1 g/cc
2.	Relative weight strength	110 -120 %	90 -110 %
3.	Relative bulk strength	155 -165 %	110 -160 %
4.	Velocity of Detonation	4000±500 m/s	3000 – 6000 m/s

These parameters shall be met before seeking Engineer's approval. Additionally, Engineer may collect random samples during any charging cycle, in case of any suspicion.

- iii. Explosive as approved by competent statutory authorities shall only be used. These explosives shall be of safe to handle and use, exhibit excellent water resistance and liberate low volumes of noxious gases.
- iv. Manual Mixing of chemicals to form any explosives shall not take place and such explosives shall not be used.
- v. Any Explosives having shelf life less than 6 months shall not be used.
- vi. Explosives being used shall be capable of performing in low temperatures.

6.10.2 Detonators

- i. Priming of the explosives shall be done only with Non - Electric detonators with shock tube containing fine spray of around 13-16 mg/m HMX/AL powder
- ii. The detonators shall be truly Non-electric in nature.
- iii. The shock tube shall be of the nature that the color of the tube gets changed post blast and can be located easily for misfires etc.
- iv. Identification tag and J - hook shall be placed at the end of the tube for identification and easy connectivity respectively.
- v. Ultrasonic seal shall be provided at the end of the tube to make it waterproof.
- vi. Shelf life of the detonators shall be one year.
- vii. Non - Electric detonators shall be safe against stray currents, static Electricity, Radio-frequency Energies and accidental initiation by impact, shock, friction and time as per the standards fixed by the appropriate authority.
- viii. The delay range of detonators should comprise of a minimum 0 - 15 delays firing completely in not less than 8000 ms for long period detonators.
- ix. Short delay series shall contain a nominal delay interval of 25 milli second (ms).
- x. Electric detonators shall not be used except for the initiation of Detonating Fuse.
- xi. Strict control over delay intervals will be required to control the blasting damage in first 50m of each tunnel portal or underground areas within 25m distance (Vertical/Horizontal) to ground surface/pre-existing underground structures. In such cases contractor shall use electronic detonators if required in opinion of Engineer in Charge. Payment shall be made to the Contractor through extra items depending on type and specification of the required electronic detonator after subtracting cost of Nonelectric detonators.

6.10.3 Detonating Fuse / Safety Fuse

- i. Detonating Fuse shall be used for connecting Non-Electric detonators.
- ii. Nominal Weight of PETN shall be 10 gm/m in detonating fuses (DF).
- iii. Detonating Fuses shall be able to get initiated by No.6 electric detonators.
- iv. Water resistance shall be excellent.
- v. Detonating fuse shall be used only to initiate the plain detonators.

6.11 WIRING

- 6.11.1** All detonators in a single blast shall be of the manufacture.
- 6.11.2** Each electric blasting cap used for initiation of shot shall be tested with an approved galvanometer (circuit Tester) to determine whether it will carry the current. All testing shall be done away from the heading face. Testing of a single detonator at any time shall be avoided.
- 6.11.3** After testing the leg wires of electric blasting caps, they shall be short circuited by twisting the 'bare ends together and shall remain so twisted until ready to be connected into the circuit prior to connection to the firing line.
- 6.11.4** Unless, the power supply is heavy it is recommended that all electric blasting caps shall be wired in series and the firing line shall not be smaller than No; 14B and S-gauge copper wire.
- 6.11.5** The number of electric blasting caps used in a circuit shall not exceed, the tested capacity of the blasting machine.
- 6.11.6** The circuit including all caps shall be tested with a circuit tester or galvanometer, operating accurately before being connected to the firing line.
- 6.11.7** In surface blasting the cartridges shall not be primed nor a hole during the approach of a thunderstorm or while it is in progress. If a charge has been primed or holes loaded, every person shall be ordered to a safe distance until the storm is over.
- 6.11.8** Blasting circuit wires and/or detonators leg wires shall never touch other wires carrying electric current.
- 6.11.9** Blasting operation control shall consist of two switches; a safety switch and a firing switch located at least 2 meters apart, the connection between the switches to be made by a “plug-in” jumper, which may be permanently attached to the safety switch. The plug-in jumper is so made that it cannot be plugged into or connected to the firing switch until the firing switch is unlocked, and the jumper must be disconnected from the firing switch before the firing switch can be locked.
- 6.11.10** Both the safety switch and the firing switch shall be of the locking, double pole, double throw type which, when opened and locked in downward position short circuit and ground the leading wires.

- 6.11.11** Both the safety switch shall be locked immediately after firing the shot and before any person can return to the area. Keys to the switches shall always remain in the possession of the starter.
- 6.12** **FUSE BLASTING** will not be allowed.
- 6.13** **FIRING**
- 6.13.1** Shots shall, so far as practicable is fired electrically and only apparatus especially designed for the purpose shall be used. Power lines shall not be tapped for the purpose. No shot shall, be fired except by a licentiate blaster authorized by the Engineer.
- 6.13.2** The charge shall be fired successively and not simultaneously.
- 6.13.3** Prior to the firing of a shot all persons in the blasting area shall be warned of the blast through audible warning and ordered to a safe distance from the area.
- 6.13.4** Competent flagmen; equipped with red flags and whistles shall be posted to stop traffic at access points on each possible route of travel to the vicinity of the blasting area.
- 6.13.5** Blasting shall be done at fixed hours approved by the Engineer and the blasting times shall be displayed on a Notice Board.
- 6.13.6** Order to fire shall be given only by the Supervisor-in-Charge of the work after giving three warning signals to enable all the workmen to reach safe shelters.
- 6.13.7** Blast shall not be fired until it is certain that every person has retreated to a safe distance.
- 6.13.8** The person-in-Charge of blasting shall be the first one to leave the area to be blasted.
- 6.13.9** A bugle or an electric buzzer with a distinctive note shall be used to give warning signals. This bugle shall not be used for any other purpose. All the labour shall be made acquainted with the sound of the bugle buzzer and shall be strictly warned to leave their Site of Work immediately for safe shelters at the first warning signal and not to leave the shelters till all clear signal has been given.
- 6.13.10** An all-clear signal shall be given when the blasting is over.
- 6.13.11** Definite places of shelter, natural or artificially constructed, shall be assigned to the crew. Workers shall be made to go to these shelters rather than trust each other's judgment about a safe place.
- 6.13.12** In special cases suitable extra precautions shall be taken. The Engineer may, however, permit blasting for underground excavation without restriction of fixed time provided he is satisfied those proper precautions are being taken and that the work of other agencies on the site is not unduly hampered.
- 6.13.13** Only Supervisor-in-Charge shall be responsible for the safe custody of the firing apparatus.
- 6.13.14** For blasts in series, only detonators of the same brand and same electrical resistance shall be used. All detonators shall be checked before use.
- 6.13.15** The firing cables shall be with a proper insulating cover to avoid short-circuiting due to encountering water, metallic parts or rock.

- 6.13.16** Use of earth, as a return line shall not be permitted.
- 6.13.17** The firing cable shall be connected to the source of current only when nobody is in the area of blasting.
- 6.13.18** Mats or rubber tyres tied together *with* rope shall be used as protection from flying debris to cover the charges where blasting may expose persons or *property* to injury or damage.
- 6.13.19** Blasting shall be permitted only after adequate provisions have been made for the protection of persons, the works, and public and private property. The Engineer's approval of any of the Contractor's blasting operations shall not relieve the Contractor of his sole responsibility for the safety of persons and property. Any damage done to the works or property by blasting shall be repaired by the Contractor.
- 6.14 INSPECTION AFTER BLASTING (Misfire drill)**
- 6.14.1** Immediately after a blast has been fired, the firing line shall be disconnected from the blasting or other source of power.
- 6.14.2** After each blasting operation the tunnel drive shall be sufficiently ventilated to remove any nitrous gases and the atmospheric conditions shall be constantly checked prior to personnel accessing the excavated face. No persons can enter the blasted area before 20 minutes after firing.
- 6.14.3** After a blast has been fired, a careful inspection shall be made by the blaster to determine if all charges have been exploded. The blaster shall count the number of the exploding shots in blasting. Misfires in fuse blasting shall not be examined for a enough time after its failure to explode. Electric blasting misfires shall not be examined for at least 15 minutes after failure to explode. Other persons shall not be allowed to return to the area of blast until an "All Clear" signal is given.
- 6.14.4** The shot-firer must keep a record of the number of shots fired, their time of firing, type and weights of explosives used per delay and total explosives used in the round and the type and number of detonators used, together with a record of the post-blast situation for each and every location. A copy of the record shall be available to the Engineer at the end of every shift on which shots are fired.
- 6.14.5** All wires shall be carefully traced, and search made for any unexploded cartridges by the person-in-Charge of the blasting operation.
- 6.14.6** Loose pieces of rock and other debris shall be scaled down from the sides of the face of excavation and the area made safe before proceeding with the work.
- 6.15 MISFIRES**
- 6.15.1** Misfired holes shall be placed in the charge of a competent person.
- 6.15.2** If broken wires, faulty connections, or short circuits are determined as the cause of a misfire, proper repairs shall be made, the firing line reconnected; and the charge fired. This shall be done, however only after a careful inspection "has been made of burdens remaining in such' holes and no hole shall be fired when the burden has been dangerously weakened by other shots.

- 6.15.3** The charge of explosives from a misfired hole shall not be drilled, bored or picked out.
- 6.15.4** Misfired charges, tamped with solid material shall be detonated by the following method:
- i. Float out the stemming by use of a water or air jet from hose until hole has been opened to within 60 cm of charge;
 - ii. Water shall be siphoned off or pumped out;
 - iii. New charge shall be placed and detonated.
 - iv. Whenever this method is not practicable; then a new parallel hole, not nearer than 60 cms, shall be drilled, loaded and detonated. A careful search shall be made of unexploded material in the debris of the second stage.
- 6.15.5** If misfire has been found to be due to defective detonators or dynamite, whole quantity or box from which the defective article was taken must be withdrawn from the works site for return to the manufacturer or destruction as decided by the Engineer.
- 6.15.6** The Contractor shall report, in writing, to the Engineer, all cases of misfire, causes of the same and steps taken in connection therewith.
- 6.16** **BLASTING FOR UNDERGROUND TUNNEL**
- 6.16.1** General
- i. Blasting in tunnels and cavities shall be carried out with Non-Electric detonators only except for the cord initiation by electric detonators.
 - ii. A separate circuit, independent of power and light circuits, shall be used for blasting.
 - iii. No electrically energized circuit shall be installed on the same side of the tunnel, or cavity with the blasting circuits.
 - iv. All electric lights or other energized circuits shall be disconnected for at least 70 meter from the point of loading.
 - v. All tracks, airlines & vent pipes shall be kept properly grounded.
 - vi. For loading purposes, the employees shall be equipped with permissible battery lamps.
 - vii. The safety switch and the firing switch shall be placed on opposite sides of the tunnel / cavity.
 - viii. Only explosives, which produce less than 0.005 m³ of poisonous gas (carbon monoxide and hydrogen sulphide) per 1.25" X 8" (3.15 cm X 20 cm) cartridge shall be used for Underground Work.
 - ix. No fire, flame, smoking or open lights shall be allowed within 6 meters from any explosive except for the purpose of firing a charge.
 - x. Adequate warning notices shall be given to air persons employed indicating the period, or danger at the time or firing and it shall be the duty of the

Contractor to provide adequate shelters or screens for protection of workers exposed to risk of injury from the explosion or from flying material.

- xi.** After the blast takes place in Underground Works the workmen shall not be allowed to go to the face till all the toxic gases are evacuated from the face.
- xii.** Under water Blasting
 - a. Only water-resistant blasting caps and detonating cord shall be used in underwater blasting operations.
 - b. Loading tubes and casings of dissimilar metals shall not be permitted because of possible electrical transient current from galvanic action.
 - c. When more than one charge is placed underwater a float device shall be attached to an element of each charge in such manner that it shall be released by the firing.
 - d. No drilling, digging or excavating shall be permitted until all misfires have detonated or the explosives are removed from the missed holes.

6.17 MONITORING OF BLAST

6.17.1 General

- i.** The Contractor shall supply and operate at least four approved Engineering Seismometer (Triaxial) or Seismograph to measure 3-components of ground vibration and air blast overpressure. The equipment shall have enough memory space to store at least 300 events and shall be equipped to measure wide range of ground vibration and air blast overpressure. It also shall be equipped with a microphone attachment, permanent paper trace output with built in strip chart printer, LCD display and PC retrieval attachment for data to be used as and where directed by ENGINEER” to monitor blasting work.
- ii.** Unless otherwise agreed in writing by “ENGINEER” trial blasts, initial blasting in general, and initial blasts in new areas and blasts adjacent to complete concrete structures and sensitive areas shall be monitored. For structures in the proximity of blasting the peak particle velocity shall be measured at the locations immediately adjacent to the structure nearest to the face being stated or another location where it is necessary to limit vibration as instructed by engineer. Apart from monitoring on its own the Contractor must provide supports for measurement to other agencies appointed by “EMPLOYER” in tunnel excavation, monitoring shall specially be undertaken with change in rock mass. in shallow cover zone and or as directed by Engineer.
- iii.** The measured vibration results shall be transmitted to “ENGINEER” together with all the useful information concerning the completed information (cut of the face / slope of the cutting face; particle size distribution of the excavated material etc.; drill marks; vibration wave form in three directions-radial,

transverse & vertical; air overpressure waveform; print out of Peak Particle Velocity (PPV) and associated predominant frequency in each direction).

- iv. Assistance shall be taken from blasting consultants / experts as specified in Quality Manual document.
- v. In case the defined thresholds be exceeded, blasting operations shall be stopped in order to finalize the new blasting pattern or the choice of another methods of proceeding with the excavations.
- vi. In general, the methods, parameters to be measured and equipment for measurement of vibration shall be in accordance with IS 14881 unless otherwise specified.

6.17.2 Restriction of Blasting

- i. All blasting works shall be completed before pouring the first structural concrete, unless otherwise specifically agreed by “ENGINEER” in writing. When excavation is carried out using explosives the Contractor shall arrange his excavation and concrete placing programmed so that as far as practicable it shall not be necessary to use explosives close to permanent construction. The Contractor shall be responsible for avoiding damage to adjacent structures from fly rock by erecting barricades and/or the use of blast mats or other means by installing shielding device acceptable to “ENGINEER”. The maximum allowable limit of noise overpressure in blasting shall not exceed 110 dB (beyond 100m in any direction from blast) In surface blasts: It must be measured close to the structure to be protected from blasting. Ground vibration induced by blasting shall be measured in terms of the Maximum or Peak Particle Velocity (PPV) in mm/s and predominant frequency of the ground vibration.
- ii. The measurement of peak particle velocity shall be obtained from instruments capable of measuring along three orthogonal axes, one of which shall be aligned parallel to the center line of the excavation and another shall be vertical. The Contractor is to provide supports for the measuring instrument if so, required by the manufacturer's instructions.
- iii. The measurements of the particle velocities (PPV) shall be the responsibility of the Contractor. Copies of the readings in an agreed form shall be supplied to the Engineer.
- iv. The following limit on peak particle velocity are given as a guide and may be modified by “ENGINEER” based on seismograph records and observations during the progress of works.
 - a. PPV shall not exceed 30mm/sec at 20m distance from the tunnel face.
 - b. For existing surface structures adjacent to excavation areas, including structures of following types:
 - (i) Not forming part of the contract,

(ii) Belonging to Employer and

(iii) Not belonging to Employer,

The frequency and peak particle velocity dependent safety criteria as per Director General of Mines Safety (DGMS) criteria shall be followed for protection of nearby structures in surface blasts.

- v. Where circumstances dictate, such as when blasting adjacent to partially cured concrete, the peak particle velocity permitted may be reduced by “ENGINEER”
- vi. For specific structures and if requested by “ENGINEER” the Contractor shall fulfill the following criteria:
 - a. At a 20 m radius of the blast, the interstitial velocity, for frequencies inferior to 100 Hertz, shall be limited to 4 cm per sec. (40 mm/sec.)
 - b. After blasting and scaling of blasted surface, 60% of the half bore holes (barrels) must be visible,
 - c. Smooth/control blasting is mandatory, in case of “Smooth blasting the spacing of perimeter holes should not exceed 40 cm c/c and the distance between perimeter row of holes and the buffer row of holes should not exceed 0.7 m.
 - d. Bores holes space is 45 cm maximum.
- vii. If necessary, “EMPLOYER” may require the Contractor to restore at his own expense any building, structure, masonry and equipment damaged by blasting, through direct or indirect effects.

6.17.3 Recording blasting operations

- i. The Contractor shall keep records of all blasting carried out showing the time and location of each blast, the type and amount of explosive used, together with any other relevant data in an agreed format approved by “ENGINEER”.
- ii. During the site works, as mentioned before each blasting pattern shall be submitted to “ENGINEER” for approval at least 24 hours before the blasting operation is due to begin. This shall be in the form of a presentation sheet setting out all the information concerning:
 - a. The type(s) of explosives to be used.
 - b. The x, y, z coordinates of each firing hole and the firing polygonal,
 - c. The diameter, depth, charge and the packing of each hole,
 - d. The method of ignition and the type of detonator for each charge,
 - e. If using a sequential exploder, the connection of the different lines and a plan showing the effective delays of the charges.
- iii. The total quantity explosives for the firing of the round: always, “ENGINEER” can interrupt the explosive operation or request the Contractor

to modify to the blasting patterns and the cost on this account shall be borne by the Contractor.

CHAPTER 7

INSTRUMENTATION

7.1 SCOPE OF WORK

- 7.1.1. This section specifies the requirements for the geotechnical measurements in the tunnels and at the surface above the tunnel designed according to the NATM for the purpose of observing and recording deformations, settlements, and load variations on supporting elements and in the adjacent rock.
- 7.1.2. As part of safety concept 3-dimensional (3-D) deformations of the tunnel lining shall be monitored by means of optical methods. The points to be observed are marked by targets or reflectors mounted on standard convergency bolts.
- 7.1.3. Measurement shall be carried out with a free-station high precision Total Station. The flow of data shall be fully automatic. The software shall allow determination of displacements in an absolute coordinate system with an accuracy of +/- 1 mm in minimum.
- 7.1.4. The work of geotechnical measurements includes the installation of geotechnical instrumentation and devices.
- 7.1.5. Necessary conclusion shall be drawn from the geotechnical measurements, from their magnitude, alterations and tendencies about stability of the primary lining and surrounding rock, performance of the initial support applied and utilization of the support elements.
- 7.1.6. The location and spacing between geotechnical measurement sections shall depend upon geological conditions, frequency of geological alterations, rock mechanical behaviour, length of tunnels, primary stress conditions, size of tunnels. The location of measurement sections shall be decided during tunneling according to the local geological conditions and the experience gained during tunnel driving and as required by the Designer or Engineer.
- 7.1.7. Reading of instruments, interpretation and evaluation of monitoring results as well as geological mapping during excavation will be carried out by the Designer/Engineer.
- 7.1.8. The Contractor shall supply, install, calibrate, test, survey and maintain instrumentation in the Tunnels, Chambers and shafts etc. as specified in this Section or as directed by the Engineer. **Minimum instrument stock for 3 months shall be maintained at site as per approved instrumentation program.** The Contractor shall supply and install all ancillary measuring equipment, read out units and construct terminal structures, protective surrounds for instruments, excavate pits and trenches, backfilling, drill holes, install pipes and fittings, and cast concrete where required. Contractor shall get approved instrumentation plan prior to installation of any instrument. All the instruments to be installed by the Contractor in all the structures shall be procured from very reputed manufacturers who have supplied such instruments at other similar projects also and have good credentials of having satisfactory working of those instruments. The specifications and the source of instruments shall be got approved by the Contractor from Engineer before procuring them.

- 7.1.9. The extent, type and location of the individual instruments as shown on the Construction Drawings, the number and location of the instruments may be altered by the Engineer during the construction period, according to the requirements.
- 7.1.10. The Contract Documents give only the numbers, general type, and general arrangement of the instruments to be supplied and installed by the Contractor.
- 7.1.11. Instruments shall be preferably vibrating wire type. All instrumentation operating on electrical or hydraulic systems shall be accompanied by individual test certificates and shall be tested in the presence of the Engineer prior to installation, unless specifically stated otherwise.
- 7.1.12. All instruments shall be installed to the lines and elevations shown on the Construction Drawings or as established by the Engineer as the work progresses during construction.
- 7.1.13. The installation of instruments may interfere with the overall construction progress. The Contractor shall make provision for any such interference in his construction planning. He will not be entitled to any compensation or extension of the Time for Completion by reason of any such delays, including repair and - replacement of damaged instruments.
- 7.1.14. No instruments or any of their components shall be purchased prior to Engineer's approval. However, approval by the Engineer of the Contractor's proposals and drawings or data shall not relieve the Contractor of his sole responsibility to meet all the requirements under this Contract.
- 7.1.15. All instruments shall be guaranteed against defects in installation / manufacturing till completion of Defect Liability Period. The Contractor at no cost to "Employer" shall replace all defective instruments during the period of guarantee. However, the buried defective instruments shall not be returned to the Contractor.
- 7.1.16. All the instruments shall be supplied with at least 3 copies of instruction manuals explaining installation procedures, Calibration Charts, guidelines, necessary protection measures and necessary maintenance requirements etc. complete in all respects.
- 7.1.17. The measuring devices to be provided shall be manufactured by a reputed manufacturer with a proven record and acceptable to the Engineer.
- 7.1.18. The Contractor shall take utmost care in the recording and analysis of the readings and prevent mixing of readings from different instruments.
- 7.1.19. During execution of the works, the Contractor shall observe, record and submit readings of all the instruments in specified format along with analysis of observed data and at specified frequency / period to the Engineer.

7.2. SUBMITTALS

- 7.2.1. Within 56 days from the commencement date, the Contractor shall submit details of the instruments proposed for the installation. These shall be consistent with the general information on the instrumentation submitted by the Contractor with his tender as well as with any modifications subsequently agreed to by the Engineer and the Contractor and shall include:
- i. Detailed description of all instrumentation, cabling and accessories including

any ancillary measuring equipment he proposes to install.

- ii. Evidence of successful performance of the instrumentation proposed for installation.
- iii. Manufacturer's instruction for the installation, testing and operation of the instruments.
- iv. Schedule of monitoring of instruments.

7.2.2. All the instruments for monitoring load on support and tunnel deformation shall be installed as soon as possible after the blast and as near as possible to the tunnel face as possible but in any case, before blasting the next round. This is an essential requirement of the proposed method of tunnel excavation.

7.2.3. The monitoring instruments must include

- i. Instrumented bolts in place of anchor Load Cells,
- ii. Strain Meter for Monitoring Rock Bolt behaviour
- iii. Stress Cell for measuring / monitoring efficacy of shotcrete
- iv. Multipoint Borehole Extensometer (MPBX) (with measuring points at 3m, 6m, 9m)
- v. Vibrating Wire Piezometer with Accessories to measure pore water pressure in ground if water seepage is observed
- vi. Optical Targets for measuring 3-D deformation using Total Station.
- vii. Deleted
- viii. Seepage Measurement System to measure flow of water from face of tunnel using V-notch
- ix. Inclinometer with accessories and Data logger to measure the slope gradient
- x. Crack Extensometer to measure rock cracks

7.2.4. Same numbers and locations of Instrumentation are envisaged for full face excavation and excavation with top heading and benching.

7.2.5. For Main monitoring cross sections, either strain meters or Stress Cells shall be installed at alternate sections.

7.2.6. Standard Monitoring Cross Section shall essentially be consisted of Displacement Monitoring Points (DMP) with Optical Targets for 3D Displacement Monitoring.

7.2.7. Deleted.

7.2.8. Deleted.

7.2.9. Main Monitoring Cross Section with Extensometer shall essentially be consisted of Multi Point Borehole Extensometer (with Measuring Points At 3m, 6m & 9m) along with Displacement Monitoring Points (DMP), Strain Meter (SM), and Stress Cell (SC).

7.2.10. The numbers, locations and frequency of instrumentation are subject to change

according to site conditions & as per Engineer's instructions on site.

- 7.2.11. During the execution of the works, the Contractor shall submit any further details regarding the instrumentation required by the Engineer. The Contractor shall prepare surveys and furnish "AS BUILT" drawings for all the installed instruments.

7.3. Specific Requirements for NATM

- 7.3.1. **General:** The Contractor shall submit a complete comprehensive instrumentation, monitoring and reporting scheme prior to any construction to achieve the following:

- (a) Safety during and after construction by providing early warning of any excessive and undue ground movement inside the tunnel.
- (b) To provide deformations and loading data for the verification of the initial and final support of the tunnel.
- (c) To provide information about tunnel behaviour in order to optimize excavation and support activities during construction

- 7.3.2. **Special Requirement:**

- a) The instruments shall be installed at locations and in accordance with a time schedule as per approved scheme or at vulnerable locations encountered during excavation.
- b) The geotechnical instrumentation and the monitoring program may be subject to alterations and modifications if required by the actual geological or geotechnical conditions.
- c) All instrumentation shall be installed in accordance with the manufacturer's recommendations and with the additional requirements specified in this document.
- d) The installed measuring equipment as well as the required space for measuring must be kept free and accessible for all the duration of construction.
- e) All instruments shall be protected against damage by blasting and tunnel traffic. Where required protective covers or housing may be used to prevent damage of the instruments.
- f) Readout units as dial gauges or tape extensometers shall be available at any time during tunnel construction. Spare parts and spare units shall be maintained on site.
- g) All instruments and equipment used and required for the geotechnical measurements shall be made available for the inspection/verification of the Engineer throughout the construction period.
- h) Sufficient length of cables shall be provided to with each installed instrument so that the accessibility for taking measurements is not hampered after benching.

- 7.3.3. **Reading & Plotting Data:**

- a) Reading of the instruments, data processing and plotting of the measurement results shall be carried out by qualified personnel of the Contractor as approved by the Engineer.
- b) For the optical displacement monitoring a software package shall be used which allows a direct data flow. This software shall include features as follows:
 - (i) Free stationing of the theodolite and calculation of standard deviation in all three coordinate directions.
 - (ii) Automatic target identification and recognition of new zero readings.
 - (iii) Calculation of 3D-coordinates and displacements of any desired point and its radial distance to the theoretical profile.
 - (iv) Correction of errors based on physical effects.
 - (v) Transformation of coordinates after control measurements.
 - (vi) Measurement results shall be tabulated and presented in graphs.
- c) The software processing the data shall include following features:
 - (i) Development of displacements with time, directly associated with tunnel driving activities.
 - (ii) Plot of displacement vectors within the cross section.
 - (iii) 3D Displacement vector orientations
 - (iv) Excavation program related evaluation and presentation of displacements (Influence lines showing the influence of daily excavation on displacements of measuring points).
 - (v) Assessment of displacements prior to zero measurement.
 - (vi) Development of differences in displacement with time e.g. roof settlement minus settlement of top heading footing.
 - (vii) Calculation of stresses and safety factors or degree of utilisation for the shotcrete lining based on optical displacement monitoring, and time dependent shotcrete strength.
 - (viii) Other evaluations as required by the Engineer and the Designer.
- d) For the monitoring of geotechnical instruments, a software package shall be used which allows a direct data flow. This software shall include features as follows:
 - (i) Presentation of data related to the time and excavation progress within one plot.
 - (ii) Cross-sectional visualisation of measuring anchor and extensometer data.
 - (iii) Multiple plot capabilities (Forces/Radial strains in rock

mass/displacements).

- (iv) Shotcrete stress calculation based on strain measurements and material law for young shotcrete as tested in situ.
- e) The first measurements (zero-readings), for each measuring instrument, shall be made immediately after installation or as soon as the particular instrument may allow.
- f) The frequency of the further measurements or readings can be envisaged for each measuring section as follows:
 - (i) 1st week: daily
 - (ii) 2nd week: twice a week
 - (iii) 3rd & 4th week: once per week
 - (iv) Later: monthly and bi-monthly
 - (v) When the bench is approaching the instrumentation, section installed during top heading, reading frequencies shall be increased again.
 - (vi) The actual frequency of readings will however be influenced by the construction stages i.e. top heading/bench heading in the tunnel and shall be proposed by the Designer through Contractor.
- g) Data of the optical displacement monitoring shall be processed on the same day and plots shall be available at late afternoon or as requested by the Engineer. Other data from measurements must be processed within 24 hours after the readings have been taken and must be plotted. All processed data and visualised diagrams must be available for the Engineer scrutiny at any time. A copy of all records shall be permanently kept on site and made available to the Engineer. If required, the Engineer may instruct shorter data processing and visualisation time.
- h) The Contractor has to immediately inform the Engineer in case he observes obvious unusual and unexpected readings or makes other unusual observations in the tunnel.

7.3.4. Methods of data evaluation and interpretation

According to geo-mechanical relevance, the main monitoring parameters for tunnelling shall be as follows:

- a) Time – Displacement Diagrams, Magnitude of Displacements Time-Displacement diagrams shall show the development of the displacement of one point versus time. Time-displacement diagrams shall be generated for all three components of the displacement vector (vertical, horizontal and longitudinal displacement). Construction phases (top heading, bench, and invert) shall be shown on the same diagram to allow for an easy correlation between displacement behaviour and construction activities.
- b) Distribution of Displacement Vectors in Cross-section - Displacement Vector

plots shall allow the representation of the cross-sectional displacements and their development with time. Displacement vector plots shall allow the detection of weak zones and / or faults outside the excavation area. They shall provide additional information about the rock mass structure and deformation phenomena close to the tunnel.

- c) Lines of Influence - Lines of Influence shall be produced by connecting displacement values of a number of monitoring points along the tunnel axis at the same time, similar to a “deflection curve”. Normally, a number of lines for a specified time span shall be shown on one plot. In addition, construction phases (top heading, bench and invert) shall be shown to allow for an immediate correlation between measured displacements and construction activities
- d) Trend Lines - Trend lines shall be generated by connecting settlement values of Individual lines of influence at a predefined distance behind the face.
- e) Development of Longitudinal Displacements close to the excavation face: This shall indicate changes in ground stiffness ahead of the face.
- f) Trend of advancing displacements due to bench excavation: This shall reflect the influence of individual bench excavation steps on the already excavated tunnel sections.
- g) Development of Differential settlements: This displacement option shall be used to show the difference in displacements between two monitoring points belonging to the same monitoring section.
 - (i) Usually the difference in settlements shall be displayed between: Crown & side wall ($S_{\text{crown}} - S_{\text{sidewall}} = \Delta S$)
 ΔS for both side walls shall be observed.
 - (ii) And for horizontal displacements between: Left and right-side wall ($H_{\text{left}} - H_{\text{right}} = \Delta H$)

7.3.5. Control limits for Trigger (Alert, Action & Alarm) levels

Monitoring parameters (including the control parameters) based on the design and anticipated ground behaviour and support performance to assess alarming situation. The examples of control parameters are:

- (i) Displacement velocities derived from 3D absolute displacement monitoring
- (ii) Differential Settlements
- (iii) Trend Lines (increase in displacements corresponding to face advancement)
- (iv) Shotcrete strains derived from strain measurements with shotcrete strain meters in the shotcrete lining.

7.4. SKILLED PERSONNEL

- 7.4.1. The whole of the instrumentation work shall be carried out under the direct supervision of a senior supervisor, approved by the Engineer, and employed by the Contractor who

is well experienced in all types of instrumentation and installation work and who understands the purpose and function of all instruments being installed.

- 7.4.2. Installation and calibration of instruments shall be carried out by skilled technicians, well experienced in the installation of instruments and who have a thorough understanding of the purpose and function of the instruments being installed, acceptable to the Engineer.

7.5. INSTALLATION

- 7.5.1. The Contractor shall install and calibrate all instrumentation conforming to the supplier's instructions and shall, where necessary, expose all partially installed instruments, cables and tubes to continue their installation, including carrying out all survey work required to locate such instruments. A representative of the instrument's manufacturer shall be present during the entire process of installation. The Contractor shall submit a certificate issued by the manufacturer regarding the installation of instruments as per the instrument's manual, to the Engineer. The Contractor shall tag all cables and tubes with identification tags approved by the Engineer at intervals of 15 m or at such closer intervals as necessary to provide continuous identification.
- 7.5.2. Instrumentation shall be installed and calibrated in the presence of the Engineer, and when he considers it desirable, instruments shall be installed preferably during daylight hours. At all times, the Contractor shall ensure that adequate lighting is available, whether by natural or artificial means, to ensure proper execution of the work.
- 7.5.3. Cables and tubes shall be installed in the maximum lengths practicable. Splicing and coupling, if essential, shall be performed in accordance with the manufacturer's recommendations. Calibration readings shall be taken prior to and immediately after splicing. Open ends of all incomplete lines of tubing and casing shall be kept plugged or sealed and the Contractor shall always during installation keep the insides of casings and tubes free from foreign matter. Cables and tubes shall be protected from mechanical damage.

7.6. CARE OF INSTRUMENTATION

- 7.6.1. No traffic or equipment shall be allowed to pass over any part of any instrument or connections unless suitably protected as recommended by the instrument supplier and approved by the Engineer. The backfill material shall be carefully compacted in such a way that the density of backfills will become equivalent to the surrounding materials to the satisfaction of the Engineer.
- 7.6.2. The Contractor shall protect all instruments and connections from damage and displacement during the progress of the work. If damage or displacement of the instruments or connections occurs during the progress of the work, they shall be repaired or replaced immediately by the Contractor.
- 7.6.3. The Contractor shall be fully responsible for the maintenance and repair of all instrumentation during the contract period.
- 7.6.4. The Contractor shall recalibrate instruments at the frequency / period as specified by manufacturer as approved by Engineer.

7.7. READING OF THE INSTRUMENTS

- 7.7.1. Calibration of all the instruments shall be done by the Contractor and all the facilities for the same shall be arranged by him. An initial set of readings on all instruments installed at any elevation will be taken immediately after their installation, and the Contractor shall not place concrete over the instruments or tubes or cables at this location until these readings have been taken.
- 7.7.2. The Contractor, after consultation with Engineer, shall program his work and make all necessary arrangements to record the reading of instruments as soon as possible after their installation. Such arrangements shall include, where necessary, the provision of temporary read out points.
- 7.7.3. During the construction, the Contractor shall read the instruments once a day till the tunnel is advanced at least 8 to 10 D distance from a monitoring location (D is the maximum dimension of excavated tunnel), and thereafter once a week till the deformations are stabilized or as directed by the Engineer. The Contractor shall inform the Engineer when reading of the instruments will take place.

7.8. INSTRUMENTATION AND MONITORING FOR STRUCTURES

- 7.8.1. The Contractor shall supply and install the measuring devices, carry out additional excavation, drilling, construct concrete or mortar pads, backfilling with concrete, perform the measurement, and record the readings at frequency / period specified by Engineer for the following instruments:
- I. Topographical markers / survey points
 - II. Automatic Weather Station
 - III. Cables
 - IV. Cable splicing kit.
 - V. Junction Boxes
 - VI. Readout units.
 - VII. Tiltmeter
- 7.8.2. The instruments shall be supplied, installed and monitored by the Contractor as directed by Engineer in order to assess the behavior of the structure and other structures during the Construction of the work.
- 7.8.3. Topographical Markers.
- I. The Contractor shall supply, install and survey studs, base plates, observation pillars and survey targets along with accessories, as shown on the drawings for precision surveying. Base plates and leveling studs shall be used to measure the vertical movements of the structure top or parapet wall & other concrete structures. Survey targets and observation pillars shall be used for measuring horizontal movement or deflection. Observation pillars shall be installed on the downstream side banks and targets mounted on the structure at various elevations as shown on the drawings.

- II. Observation pillar shall be of size 600 mm X 600 mm X 900 mm (projecting 300 mm above ground), RCC of M30 Grade having 4 nos 10 mm longitudinal reinforcement bar with 4 nos 6 mm reinforcement bar stirrups. Observation pillar shall be of size 600 mm X 600 mm X 900 mm (projecting 300 mm above ground), RCC of M30 Grade having 4 nos 10 mm longitudinal reinforcement bar with 4 nos 6 mm reinforcement bar stirrups.
- III. Survey studs shall be of stainless steel of 15 mm Ø and 250 mm long and of the shape and size as shown on the drawings.
- IV. Leveling studs/ base plates shall be installed as soon as possible after placement of concrete at the locations where required. The base plate shall be 100 X 100 X 3 mm stainless steel plates or brass plate with 4 MS spikes (hold fasts) about 5 mm Ø X 70 mm long to hold the plate in concrete. The top surface of the plate shall be a perfect plane.
- V. Survey targets shall be made of solid brass or stainless steel of about 35 mm Ø on top and 75 mm long. Its top there will be an engraved cross mark 1 mm thick and 1 mm deep. The Contractor may suggest some different type of targets also for approval of the Engineer.
- VI. Immediately after installation of any studs / base plates, its position and level shall be precisely surveyed. The level and coordinates shall be computed and submitted in writing to the Engineer within 24 hours of installation.
- VII. Thereafter, the Contractor shall read the targets once a day till the tunnel is advanced at least 8 to 10 D distance from a monitoring location (D is the maximum dimension of excavated tunnel), and thereafter once a week till the deformations are stabilized or as directed by the Engineer. The Contractor shall inform the Engineer when reading of the instruments will take place.

7.8.4. Automatic Weather Station

- I. Contractor shall supply and install weather station (automatic type) and take observations during construction period and hand over to the Employer at the end of the construction period.
 - A. The Automatic Weather Station (AWS) must permit to record automatically and continuously the following meteorological data:
 - a) Wind speed
 - b) Air temperature
 - c) Rainfall
 - d) Relative humidity
 - B. The Sensors of the AWS shall meet the following requirements:
 - a) Wind speed Sensor

Range : 0.5 to 100 m/s

- Resolution : 0.5 m/s
- b) Air temperature Sensor
- Range : -10°C to +60°C???
- Resolution : 0.1°C
- c) Rainfall Sensor
- Maximum Range : 10 mm /min
- Resolution : 0.02 mm
- d) Relative humidity Sensor
- Range : 5% to 99%
- Resolution : 0.1%

- C. The sampling interval shall be adjustable from 1 to 3 hours.
- D. All the sensors must be operated with solar cells with provision for power module.
- E. DELETED.
- F. The data storing unit of the AWS shall have the facility to store all data for a period of at least 6 month and shall permit instant display/USB transfer of data.
- G. The Contractor shall supply and install a complete AWS including all instrument shelters within one month from the date of commencement.

7.8.5. Cables

- I. Cables connected to instruments shall be laid as per the detailed cable routes submitted by the Contractor and approved by the Engineer.
- II. Cables shall generally be of following types:
- A. 12 core cable: it shall have 7 / 0.25 mm ATC PE insulated, with six twisted pair (12 core), color coded, screened with water blocking aluminum foil or jelly filled, polyester taped, inner polythene sheeted, 0.3 mm galvanized iron wire braid armored with 50 % coverage, overall polythene sheathed and overall diameter of around 14 mm.
- III. Special cables, where required, for various gauges shall be of standard market quality, as approved by the Engineer.

7.8.6. Cable Splicing Kit

- I. It is required for joining two cable ends of four-core cable. It shall be suitable to make a water resistance sealed joint and shall have requisite amount of cable jointing compound like epoxy and silicon grease. The splicer shall be made of

stainless steel and shall be able to withstand a pressure of 30 kg / cm² and a tensile force of 12 KN.

7.8.7. Junction Box

- I. The junction box shall be mounted at appropriate locations as shown on the drawings or as directed by the Engineer. The junction box shall be a device to provide connection between core cables leading from the different instruments and multi-core cables leading to the multiplexer unit. The junction box should have a connector socket for the fly leads from the portable read out unit and a rotary switch to select individual instruments.
- II. All switchable junction boxes shall be double ended. This is essential to remove the possibility of one rogue instrument interfering with the performance of the others. The junction box shall have an arrangement for connecting minimum 20 instruments. The wires and terminals within the junction box shall be fitted with entrance hubs to protect them against danger of water penetration.
- III. The junction box shall be of drip tight sheet steel and shall be provided with stuffing box for special measuring cables and connecting cables and shall have built in terminals and socket strips. The junction box shall be provided with an arrangement for protection against over voltage. The sheet steel metal construction of the distribution box shall be properly treated and coated with corrosion resistant paint. The junction box shall also be provided with an arrangement for earthing and shall be supplied along with its accessories. The specifications for the junction box given herein indicate broad requirements only.

7.8.8. Tiltmeter:

- I. Tiltmeters shall be installed at appropriate locations on structures to measure small changes of inclination due to tunnel construction.
- II. The position of the tilt meter should be determined immediately after installation and parallel to the zero measurement.

7.9. SPECIFICATIONS OF INSTRUMENTS

7.9.1. General

- I. The Contractor shall supply and install the measuring devices as shown in the drawings of various underground works or as directed by the Engineer to carry out additional excavation, drilling, construct concrete or mortar pads, backfilling with concrete, perform the measurement, and record the readings at frequency / period specified by Engineer for the following:
 - A. Topographical markers/ survey points.
 - B. Load cells
 - C. Measuring tape extensometer
 - D. Tape convergence points

- E. Single and multiple point borehole extensometers
 - F. Readout units.
 - G. Bi-Reflex Targets and Electronic Total Station.
 - H. Stress Cells.
 - I. Piezometer.
 - J. In place inclinometer
 - K. Data logger for in-place Inclinometer to log data from IPI sensors.
- II. The measuring devices to be provided shall be manufactured by a reputed manufacturer with proven record and acceptable to the Engineer.
 - III. The Contractor shall take utmost care in the recording and analysis of the readings and prevent mixing of readings from different instruments.
 - IV. During execution of the works, the Contractor shall observe, record and submit readings of all the instruments in specified format as approved by engineer along with analysis of observed data and at specified frequency / period to the Engineer.

7.9.2. Load Cells

- I. Only vibrating wire-based Load cells shall be installed to monitor the behavior of steel ribs/Lattice girder supports installed.
- II. The load cells shall have the following characteristics:
 - A. Capacity : 300kN
 - B. Overload Capacity : 150 % of Full scale
 - C. Accuracy : 0.5 % of Full scale
 - D. Material of Element : Stainless Steel
 - E. Remote electrical read out unit :
- III. Each load cell shall be supplied with a cable of 20 m length.
- IV. At the beginning, the readings shall be taken daily. Later, weekly readings shall be taken till the cessation of any movement or until the Engineer permits termination.

7.9.3. V.W wire based instrumented bolt (Rock bolt load measurement)

- I. It shall be 4-point VW type instrument installed at every 100m or as directed by engineer and shall measure load at 3-4 places along the same rock bolt.
- II. It is required to measure load on rock bolt at various depths after installation.
- III. It shall have the capacity to measure load upto 300 KN with 0.5% accuracy.

7.9.4. Tape extensometer

- I. It is required for measuring distance for “Convergence measuring points”. It shall have the following characteristics:
 - A. It shall be temperature resistant, water resistant and tear resistant Tape.
 - B. The tape shall be not less than 30 m in length.

7.9.5. Convergence Measurement

- I. Convergence measurement shall be performed in underground excavation works to determine the relative displacement of opposite measuring points placed around the excavation perimeter.
- II. The measuring points shall consist of convergence bolts made of stainless-steel pins molded on a short reinforcing bar grouted into predrilled hole.
- III. The distance changes between the opposite convergence bolts shall be measured by means of tape extensometer connected to the bolts and tensioned between them. Change of length shall be read on a digital gauge. Reproducibility of measurement shall be ± 0.5 mm.
- IV. The distance changes between the opposite convergence bolts may be measured by means of Total station also.
- V. The convergence bolts shall be installed within the heading zone after the installation of supports. At the beginning, the measurement shall be carried out daily. Later weekly readings shall be taken for several months up to the cessation of any movement by latest when the placing of the concrete lining commences. The convergence measuring tape extensometer and the digital gauge shall be calibrated on their corresponding calibration devices before and after each measurement. Digital readout shall be in metric unit. Whenever instructed by engineer, the same shall be replaced by reflector type paper target points which can be remotely spotted for convergence measurements. Removable bi-reflex optical targets shall be installed as near as possible from the face along with protection caps to prevent damage during blast.

7.9.6. Vibrating Wire type Multipoint Bore-Hole Extensometers to accommodate in 45-50 mm dia holes)

- I. These extensometers shall be installed in underground excavation to measure displacements in the rock mass surrounding the excavation.
- II. The extensometers shall be installed in the boreholes drilled radially on a plane perpendicular to the centerline of the underground structure. The exact location of each measuring section will be determined by the Engineer.
- III. The borehole diameter should be less than 50 mm or as recommended by the supplier of the extensometers. The measuring heads shall be installed in recesses excavated around the collar prior to the drilling of the hole and shall be protected from damage by a cover plate.

- IV. Extensometers will have a typical rod length of 2,5,10 and 20.
- V. Reading of the extensometers shall be done with a readout unit. At the beginning, the readings shall be taken daily. Later, weekly readings shall be taken till the cessation of any movement or until the Engineer permits termination but latest when the placing of the concrete lining commences. The readings so taken along with report (comprising of data observed, analysis of data etc.,) shall be reported to the Engineer.

7.9.7. Electronic Total Station:

The electronic total station shall have the minimum precision:

- I. Horizontal angle measurement : +/-1" (0.3 mgon).
- II. Vertical angle measurement : +/-1" (0.3 mgon).
- III. Distance measurement : +/- (1 mm+ 1.5 ppm).

7.9.8. Absolute 3D Displacement Monitoring

- I. Absolute monitoring shall be performed in underground excavation works to determine the spatial position of measuring points placed around the excavation perimeter.
- II. The measuring points shall consist of the targets mounted on special bolts.
- III. The targets should be installed immediately behind the face on the last round and zero reading should be taken. Construction sequence (top heading- bench excavation etc.) should be recorded simultaneously with absolute displacement monitoring.

7.9.9. Stress Cells:

Shotcrete/ Concrete Stress cells NATM style vibrating wire stress cells to measure radial and tangential stresses in shotcrete or concrete. Capacity of stress cells - tangential 200Kg/cm² and radial 50Kg/cm². Accuracy of 0.5%, each cell should be marked with capacity, serial no. etc. along with the sufficient Teflon / PVC or similar cable shielded, integral with stress cell for taking observations using the proper readout, Connections/switch/junction box to be attached to the cable stress cell for connecting to readout. The readout should be compatible to vibrating wire stress cell, rechargeable battery operated, LCD display, stress cell should be calibrated with this readout, connector to connect the stress cells, perfectly sealed to make it dust and moisture proof including battery charger and one extra rechargeable battery.

7.9.10. Piezometer:

Supply, fixing and monitoring (as per specifications) of Piezometer (vibrating wire sensors type) as per the drawing or as per directed by Engineer-in-charge. The piezometer shall be designed for water table measurements and measuring pore pressure up to 2MPa with an accuracy of +/-0.5% of full scale The rate shall include all accessories required for installation and as per approved method statement.

7.9.11. In place inclinometer:

Supply, Installation and monitoring of in place inclinometer to measure lateral movement in slope & embankment suitable for depths up to 30 m. Each Inclinometer system consisting of following accessories complete in all respect:

1. Biaxial sensor with SDI-12@ 3 m interval, with pair of wheels for up to 30m depth
2. Suspension kit with protective cap and placement tubing: 1No.
3. Spacer assembly for 3 m gage length
4. Bottom wheel assembly with plug: 1no.
5. Protective rope to prevent loss of sensor down hole: 1no.
6. Suspension stainless steel wire rope for positioning sensors: 1 no.
7. Self-aligning ABS tubing, 70mm OD, 58 mm ID, 3 m length for up to 50m depth.
8. ABS fixed coupling for 70 mm OD. Access tube, 77 mm OD x 160 mm length as required for jointing of ABS tubing.
9. Bottom cap for ABS tubing: 1no.
10. Dummy probe with 30 m cord: 1no.

7.9.12. Data logger for In-place Inclinometer to log data from IPI sensors having Memory capacity 2 million data points and communication port to download data on Laptop/ PC. Real time accuracy: +/- 1 minute/ year.

7.10. Readout Unit for Electrical Instruments

7.10.1. The Contractor shall supply a readout unit for load cells and Extensometers.

7.10.2. The read-out unit shall be portable, battery operated, designed to read vibrating wire gauge/ resistance gauges / thermistors. The LCD display shall present maximum information including output signal period, linear or frequency reading, gauges temperature, thermistor's Ohm value gauge factor and type.

The unit shall be able to log data having minimum 500 channels and 2000 readings. Power supply shall be through rechargeable battery.

Note: Monitoring, Recording and the Control Process of Underground works is mentioned in Annexure to Chapter 7: Instrumentation.

ANNEXURE TO CHAPTER 7**INSTRUMENTATION MONITORING RECORDING AND THE CONTROL PROCESS
OF UNDERGROUND WORKS****1.1 GENERAL**

- a) The Contractor shall submit to the Engineer for agreement a detailed method statement for instrumentation and monitoring, including instrumentation layout, trigger, design and allowable values and procedures for evaluating the monitored data.
- b) The Contractor shall appoint within his site team an experienced Instrumentation & Monitoring Engineer who shall lead the Contractor's monitoring team. The Instrumentation & Monitoring Engineer shall present the results of the previous day's monitoring in the daily monitoring meeting with the Engineer where they shall be presented to the Engineer by the Instrumentation & Monitoring Engineer.
- c) The frequency of such review meeting may be increased if requested by the Engineer.
- d) The Contractor' Tunnel Construction Manager shall attend monitoring review meetings if requested by the Engineer.
- e) The accuracy and precision of the measurement required will depend on the purpose of the monitoring.
- f) Assessments shall be carried out to establish the zone of influence due to tunneling works and to determine the likely damage that will occur to existing above ground and subsurface infrastructure.
- g) The outcome of the assessments shall determine the type and amount of monitoring that will be required.
- h) Early preconstruction instrumentation requirements shall be determined so that baseline measurements can be taken for an appropriate period, to establish the stability of the monitoring system and any possible effects of any underlying environmental trends that could be attributed to the Works.

1.2 Ground Monitoring

- a) Unless otherwise provided for in the contract, the Contractor shall monitor the effects of tunnel construction at the surface including all ground movements and the effects on all structures, including the Works. Where specifically requested, the subsurface effects, including movements of the water table, shall also be monitored.
- b) Unless otherwise provided for in the contract, monitoring equipment and instruments shall be provided by the Contractor to enable the response of structures to be determined, Equipment and instruments shall be installed to the manufacturer's instructions and shall be calibrated and tested as appropriate.

Monitoring pins and devices shall be securely fixed in position. Due regard shall be given to the construction of the structure to be monitored and the layout of its primary support.

- c) Monitoring shall be referenced to stable survey stations located outside the zone of influence of the Works and not subject to ground movement. Such benchmarks and coordinated stations shall be established and agreed with the Engineer before any ground is excavated and before any ground treatment or dewatering takes place. They shall be checked at intervals during the duration of the Works.
- d) The Contractor shall observe, record and analyze the readings to establish trends in movement and reconcile movements measured with those predicted. He shall provide a copy of all recorded results to the Engineer. He shall make available results to the Engineer in accordance with an agreed programme: however, movement greater than predicted shall be reported to the Engineer immediately.
- e) Prior to Construction Works commencing, a defect survey shall be carried out of all structures within the zone of influence and a schedule of defects shall be prepared. This schedule shall be agreed by the Contractor and the owner of the structure, or his representative, prior to the start of construction. Existing pipelines, tunnels and services shall be regarded as structures.
- f) During the execution of the Works, defects which have been scheduled shall be inspected and monitored as necessary. Defects which arise during the course of the works shall be recorded. The Contractor shall keep records of such inspections and a copy shall be available to the Engineer.
- g) Monitoring of settlement, scheduled defects and defects arising during the course of the works shall continue at agreed intervals for a period of at least 6 months after completion.

1.3 Monitoring of Tunnel Excavation

- a) The Contractor shall survey, monitor and record tunnel and shaft construction as it proceeds, to form a record of the work. Monitoring shall generally be per unit of advance and include line, level, cross-sectional accuracy, shift advance, total advance.
- b) Where grouting is carried out, the type, volume and pressure of grout shall be recorded.
- c) All information recorded by the Contractor shall be provided to the Engineer on a daily basis unless another interval has been agreed.
- d) Where the Contractor considers that any corrective actions he may take will exceed the tolerance in the contract he shall so inform the Engineer and obtain his agreement.
- e) The strata exposed in the tunnel face shall be mapped and recorded where possible and the nature of the excavated material shall be noted in all cases.

- f) All significant groundwater ingress shall be recorded and monitored.
- g) All atmosphere testing shall be recorded and monitoring for all gases carried out in accordance with relevant code.
- h) The Contractor shall keep copies of all recent face records at the workface for the information of supervisory personnel.

1.4 Daily Review Meeting (DRM)

- a) The monitoring instrumentation shall be read on a regular basis- as per Drawings and monitoring plan and the record made available for a Daily Review Meeting (DRM) attended by the Senior members of the Contractor's and the Engineer's staff. Input into the meeting shall also include current Geotechnical Investigations, Measurement While Drilling (MWD) report, face logs, and any recent non-conformance reports relating to the tunnel construction.
- b) This DRM shall be held daily during the excavation of the tunnels unless otherwise agreed by the Contractor and the Engineer.
- c) At the meeting the Contractor shall present the current results of monitoring of the tunnels, together with records on these results and comparison with the deformation predicted by the calculations.
- d) The outcome of the meeting shall be a report Required Excavation and Support Sheet (RESS) agreed by the Contractor and Engineer, which states that tunneling may continue as proposed or gives the requirements for modification to the tunneling (e.g. shorter advances, smaller heading).
- e) If no agreed report is available by a specified time each day then the tunnel shall be made safe and tunneling be stopped.
- f) All records from these meetings including face logging and monitoring results shall be kept and be available for inspection until the termination of the contract.

1.5 Key Performance Indicator (KPI)

- a) A Key Performance Indicator (KPI) system shall be developed for monitoring movements so that action can be taken in a timely manner, thereby ensuring that damage to existing buildings and subsurface infrastructure is within calculated predictions.
- b) The KPIs to be used to guide construction shall relate to specific monitoring activities.
 - i. In-tunnel convergence monitoring (SCL)
 - ii. Ground movement monitoring
 - iii. Monitoring of adjacent and overlying structures.
- c) The KPI values specified in the design documentation shall be used to indicate whether or not there is cause for concern during tunnel construction. To ensure

that the response is appropriate for any specific concern, certain procedures shall be implemented when a KPI is exceeded. These are summarized below:

- i. A full review of the lining performance shall be conducted for the relevant tunnel section and checked against the KPI values. This includes checks on the ground/soil conditions, the quality of construction and the monitoring results provided by the Contractor.
- ii. A comprehensive review of the trends for monitoring data specific to the area of concern shall be carried out by the Contractor and the Engineer.
- iii. The Contractor shall assess the extent to which the deformations comply with the SCL serviceability and extreme limit conditions.
- iv. Together with the Engineer, the Contractor shall decide whether changes in the SCL excavation sequences are required. This is an interactive process that will determine whether it is safe to proceed with construction or, if there is reasonable cause for concern, the extent to which it is necessary to implement additional measures or emergency procedures. These measures will be included in a new RESS.
- v. The Contractor and Engineer shall implement the Action Plan, the emergency response to implement contingency measures. If there is reasonable cause for concern, it is emphasized that the response must be rapid.
- vi. The performance of the tunnel is kept under continuous review until the monitoring data indicate that KPI trends show a stable condition.
 - a) At least three trigger values shall be established: a green, amber and red limit. The green limit marks the boundary of normal behaviors. The amber marks the boundary of serviceability while the red trigger should be set below the ultimate capacity of the lining. The Contractor's Action Plan should include pre-planned contingency measures that can be taken if a trigger value is exceeded.
 - b) If a trigger value is reached, first the site team should check that the reading is correct and consistent with the readings from other instruments. If the rigger has really been breached, then contingency measures will be investigated in accordance with a predefined Action Plan and as directed in the DRM. The contingency measures are designed to correct any anomalous behavior.

1.6 RESS- Required Excavation and Support Sheet

- a) Based on the design and the evaluation of the result of monitoring, a RESS will be issued at the outcome of the Daily Review Meeting (DRM). In the absence

of any approved changes the RESS will reflect exactly what is shown on the relevant design drawings.

- b) The RESS shall be prepared and endorsed by the Contractor's Tunnel Construction Manager responsible for the tunneling works, the Designer (for specific issues) and the Engineer on site. Unless all the three signatures are obtained, the proposals indicated on the RESS shall not be implemented.
- c) The RESS shall address, but not necessary be limited to the following matters:
 - i. The tunnel section (chainages) to which the RESS is applicable
 - ii. The support to be installed
 - iii. The excavation sequence
 - iv. The method of working related to ground support including staging of application of sprayed-concrete layers and lapping of reinforcement.
 - v. Monitoring to be installed in the tunnel section in question
 - vi. Measures to be taken during stoppage of works
 - vii. Other instruction relevant to the tunnel section in question
 - viii. Reference to relevant Design Drawings
- d) A copy of the RESS will be given to the Head Foreman in charge of the work in the tunnel and shall be kept at the working face.
- e) A RESS is required for every metre of the length of the tunnels.
- f) If for any reason the approved design method of working is changed, then this will be reviewed prior to the DRM and subject to acceptance by the Engineer a new RESS will be issued.

1.7 Contingencies measures and Emergencies procedures

- a) The Contractor shall determine contingency measures to deal with potential hazards that may affect the Works. The Contractor shall submit for approval to the Engineer an action plan which shall detail the actions, procedures and contingency measures to be followed in the event that the monitoring system shows unacceptable levels of deformation movement if potential hazards occur.
- b) Hazards to be addressed include
 - i. changing ground condition
 - ii. excessive movement of the linings
 - iii. Excessive ground movement
 - iv. Excessive settlement of the existing structures
 - v. Unplanned stoppages

- vi. Mechanical excavation plant failure
 - vii. Insufficient labour resources
 - viii. Failure of services to underground work (air, light, power etc.)
 - ix. Incidents within underground works
 - x. Delay in supply of sprayed concrete (SCL)
- c) In underground construction works, changes tend to be progressive with evidence of structure or ground behavior becoming apparent before failure occurs. For this situation a system of hierarchical trigger levels will be appropriate. This allows proportionate response to adverse indications from monitoring.
- d) Trigger levels will be based on the results of assessments of at-risk infrastructure. If the assessment indicates that the at-risk infrastructure is unlikely to be able to tolerate the change due to the Works, then triggers will be set based on the levels of change that will be tolerable.
- e) There may be some situations where change is less progressive and monitoring may simply be required to give a yes/no response. In these cases, reporting is simple and systems of triggers are not appropriate.

CHAPTER -8

UNDERGROUND EXCAVATION

8.1 GENERAL

- 8.1.1** The specifications described herein under relate to the excavation work for the underground structures and shall include all labour, materials, equipment all drilling and blasting, loading, transporting and disposal of materials in spoil or stockpile areas as well as the removal of all loose material and cleaning of excavated surfaces, to be carried out by the Contractor under this contract. In general, the excavation work shall be done by mechanical equipment or drill and blast (DBM) and in exceptional cases, by manual means.
- 8.1.2** Excavation shall be made to the lines, grades and dimensions shown on the drawings or as otherwise directed by the Engineer, which shall be required to be backfilled with acceptable material and compacted by contractor in a manner acceptable to the engineer.
- 8.1.3** Structural supports, structural steel support, rock bolts, shotcrete, grouting, concrete lining and dewatering works are covered in other chapters of Outline Construction Specifications.
- 8.1.4** The Contractor shall be required to perform surface exploratory drilling during excavation of the tunnel whenever required.
- 8.1.5** The approval given by the Engineer to the Contractor's methods and equipment shall not relieve the Contractor of his full responsibility for proper and safe execution of underground excavations, or liability of injuries to or death of person or any obligations under this contract.
- 8.1.6** The Contractor shall comply with all safety procedure and requirements as stipulated elsewhere in the tender documents.
- 8.1.7** All excavations done inside ground with overlying material left in place shall be treated as underground excavation.

8.1.8 STANDARDS:

The specifications, production, working etc. shall conform to the following latest Indian Standards or where not covered by these Standards, to the equivalent International Standards. The list is for guidance purpose only. The Contractor shall abide by all codes/regulations/specifications as are deemed necessary for the satisfactory completion of work.

Railway Guidelines:

- i. GE-G-0015 – Guidelines for Civil Engg. Inspection, Maintenance and Safety in existing Tunnels.
- ii. GE-G-0016 – Guidelines for Safety in Tunnels during Construction.
- iii. GE-G-0017 – Guidelines for Design and Construction of Tunnels

Indian Standards:

- iv. IS: 4756: - 1978 – Safety Code for Tunnelling work
- v. IS: 3764 –1966 – Safety Code for Excavation work
- vi. IS: 4081-1967 – Safety Code for Blasting and Related drilling operations
- vii. IS: 4138-1977 – Safety Code for Working on Compressed Air
- viii. IS: 7293-1974 – Safety Code for Working with Construction Machinery
- ix. IS: 5878 (Various parts) – Codes of practices relating to tunnelling and underground excavations
- x. Indian Explosive Act -1988
- xi. Indian Explosive Rules -1983
- xii. IS: 823 -1964 – Code of procedure for manual metal Arc welding of mild steel
- xiii. IS: 816-1969 – Code of practice for use of Metal Arc welding for General Construction in Mild steel.

8.2 SUBMITTALS

8.2.1 At least 28 days prior to the commencement of underground excavation, the Contractor shall submit details of his excavating methods and sequences for all underground works and portal excavation, including equipment, ventilation air cooling equipment, rock support, details of methods for drilling probe holes, grouting and safety measures. Contractor shall get approval for excavation and sequences from the Engineer.

8.2.2 The description of drilling and blasting procedures shall include the following:

- i. Diameter, spacing, depth, pattern and orientation of blast holes.
- ii. Pattern of delays to be used per blast.
- iii. Sequence of various activities of the excavation works in different. Heading faces with indication of corresponding time requirements.
- iv. Excavation methodology shall include proposed exaction cycle time for each class of rock mass along with advance rock stabilization measures.
- v. The details to be backed up by supporting calculations & details of trials.

8.2.3 To enable the Engineer to verify all necessary setting out and elevations carried out by the Contractor, the latter, shall notify the Engineer in writing, giving at least 1 (One) week notice of his intention to start excavation.

8.2.4 During the advance of underground excavations, the Contractor shall record and submit weekly to the Engineer, 3 copies of the following:

- i. Advance of each heading face and chainage of heading face before the blasting of each round.

- ii. Amount, location, spacing, and type of steel support/Lagging installation in various zones, as defined hereafter.
- iii. Surface area of shotcrete installed in various zones.
- iv. Number, length, and type of rock bolts installed in various zones.
- v. Occurrence of gas, if any.
- vi. Water inflows at the heading face including its temperature.
- vii. Personnel employed during various stages of the operation and their qualification.
- viii. Unusual occurrences, all delays and the reason of delays.
- ix. Type and number of drill holes, and length of each round.
- x. Pattern of drill holes their diameter and length.

8.2.5 The Engineer reserves the right to require any additional information deemed necessary to be included in the submitted documents.

8.2.6 For geological overbreak and adverse geological occurrence Contractor shall be responsible for preparing geological plans and survey plot cross section at required intervals by tunnel profiler to allow for reasonably accurate assessment of the volumes and taking video / still photographs of overbreak in the presence of the representative of Engineer and providing copies of the same to "ENGINEER". The exact locations and / or chainage shall also be included therein. Such incidences shall be reported immediately to the ENGINEER. Detailed report on adverse geological occurrences shall also be prepared along with probable reasons and submitted to engineer as soon as possible. All cavity and voids formed due to geological overbreak shall be measured in situ, quantified and proposed by contractor for immediate approval of Engineer, If possible, before the excavation of the subsequent blast.

8.2.7 The drilling parameters retrieved from the Jumbo machine will be submitted to the Engineer before every blast.

8.3 DEFINITIONS

8.3.1 Conventional Excavation

Excavation performed underground by conventional methods using mechanical means (except TBM) or drilling and blasting and in exceptional cases, by manual means.

8.3.2 Tunneling Face

The advance end of a tunnel at which the work is progressing.

8.3.3 Heading Zone

Heading zone refer to tunnels (upstream and downstream headings) excavated by conventional method and is defined as a zone between the newly established face and 7m or equal to the excavated diameter of the tunnel behind the face, measured along the tunnel centerline.

8.3.4 Rear Zone

Rear Zone is the whole length of tunnel between the heading zone and the portal.

8.3.5 Excavation Rate per working day

The daily excavation rate is the average of daily rates calculated over a period of 1 month.

8.3.6 Working Days (WD)

Working days are calendar days on which work is performed. When working days are mentioned in writing, they must be indicated with additional indices such as WD1, WD2 or WD3 in order to show whether on the day in question 1, 2 or 3 shifts will be working.

8.3.7 Crown

Crown is the top arch of the tunnel above the spring line.

8.3.8 Spring Line

The level at which overt and vertical I wall of the tunnel meet is called Spring level and horizontal line passing through the junction points of tunnel is called Springing Line.

8.3.9 Round length (Pull): Maximum distance (along tunnel axis) between any two points on two successive tunneling faces by which the excavation is advanced from previous face to next face by conventional drill and blast or any other method in one go.

8.4 General

8.4.1 The Contractor shall always be responsible for the safety and security of excavations during the execution of the Contract.

8.4.2 Mechanized techniques for excavation shall be used.

8.4.3 Excavation shall generally be full face, heading and benching or multi-drift as defined in the construction drawings.

8.4.4 The Contractor shall provide details of his proposed methods for excavation support and spoil removal to the Engineer for agreement. No excavation shall take place until the Engineer's agreement has been obtained. Such agreement shall not relieve the Contractor of any of his obligations under the Contract.

8.4.5 Excavation shall be carried out in a uniform and controlled manner and over-cutting shall be kept to a minimum consistent with the need to maintain the necessary clearance for construction of the Works.

8.4.6 The invert of the tunnel shall be protected against damage and deterioration which may be caused by construction traffic. Any other surfaces which deteriorate or are damaged shall be made good to a standard agreed with the Engineer. After invert casting, tunneling muck will be filled, levelled and compacted over concrete invert.

8.4.7 Excavation shall be carried out in sections limited to such lengths, depths and widths as may be safely executed having regard to all the circumstances and as appropriate to the ground conditions and the equipment and method of construction being used.

- 8.4.8** In water-bearing strata the Contractor shall use such methods and take such steps as are necessary to control flows and maintain the stability of the excavation.
- 8.4.9** Where necessary to ensure the safety and security of the Works, excavation shall be continuous by day and night.
- 8.4.10** Weekends, general holidays and enforced stoppages will require the Works to be made safe and inspected by the Contractor at intervals agreed with the Engineer.
- 8.4.11** Any voids formed during the excavation process by machine overcut slips, falls of material, overbreak and temporary works shall be filled either completely or partially in agreement with engineer, with grout, concrete, sprayed concrete or other approved durable material.
- 8.4.12** Where the Contract specifies limits to surface settlement and/or protection in respect of existing services or structures, the Contractor shall provide calculations demonstrating that the method of excavation will result in compliance with those requirements. Details of the monitoring arrangements which are proposed for the recording of movements and the verification of the degree of any settlement or damage to services or structures shall be in accordance with the specified limits.
- 8.4.13** Where agreed or required by the Engineer, temporary support shall be left in the Works. Generally, untreated timber shall not be left permanently in the Works.
- 8.4.14** The volume of excavated material shall be measured and recorded as the Works proceed. The Contractor shall present to the Engineer after every 50m of advance, a Chainage wise reconciliation of volumetric advance of tunnel against volume of materials excavated and quantum of support installed (Bolts/Shotcrete), concrete placed, length of drilling of holes and grout injected.
- 8.4.15** All excavation shall be carried out to a profile as close as possible to the specified minimum excavation line.
- 8.4.16** The Contractor shall be constantly aware of the possibility of slips and ground movement which may be caused by his method or order of excavation. He shall maintain on-site material, and equipment, for use in ensuring the stability of the face.
- 8.4.17** The proximity of other tunnels and excavations shall be considered when determining the method of excavation.
- 8.4.18** Enlargement of tunnel cross section or excavation of bypass tunnel shall also be done as wherever required as per instruction of Engineer.

8.5 EXCAVATION LINES AND TOLERANCES

8.5.1 Definitions:

- i. **Theoretical excavation line:** The excavation profiles as shown on the cross-section drawings refer to the theoretical excavation lines.
- ii. **“A” Line** – Depending on the quality of the rock, an appropriate enlargement of the theoretical excavation profile shall be made in order to provide enough

space for the anticipated radial deformations. The “A” Line takes into consideration the anticipated radial deformations above the theoretical excavation line.

- iii. **“B” Line** – Line within which neither rock bolts nor sprayed concrete or any part of the primary support shall intersect except for bolt end hardware.
- iv. **“C” Line** – A Line within which the final lining shall not protrude and be constructed within -0/+50mm radially (Negative value radially inward). The Contractor shall accommodate all his construction tolerances for excavation and support installation within this given allowance.

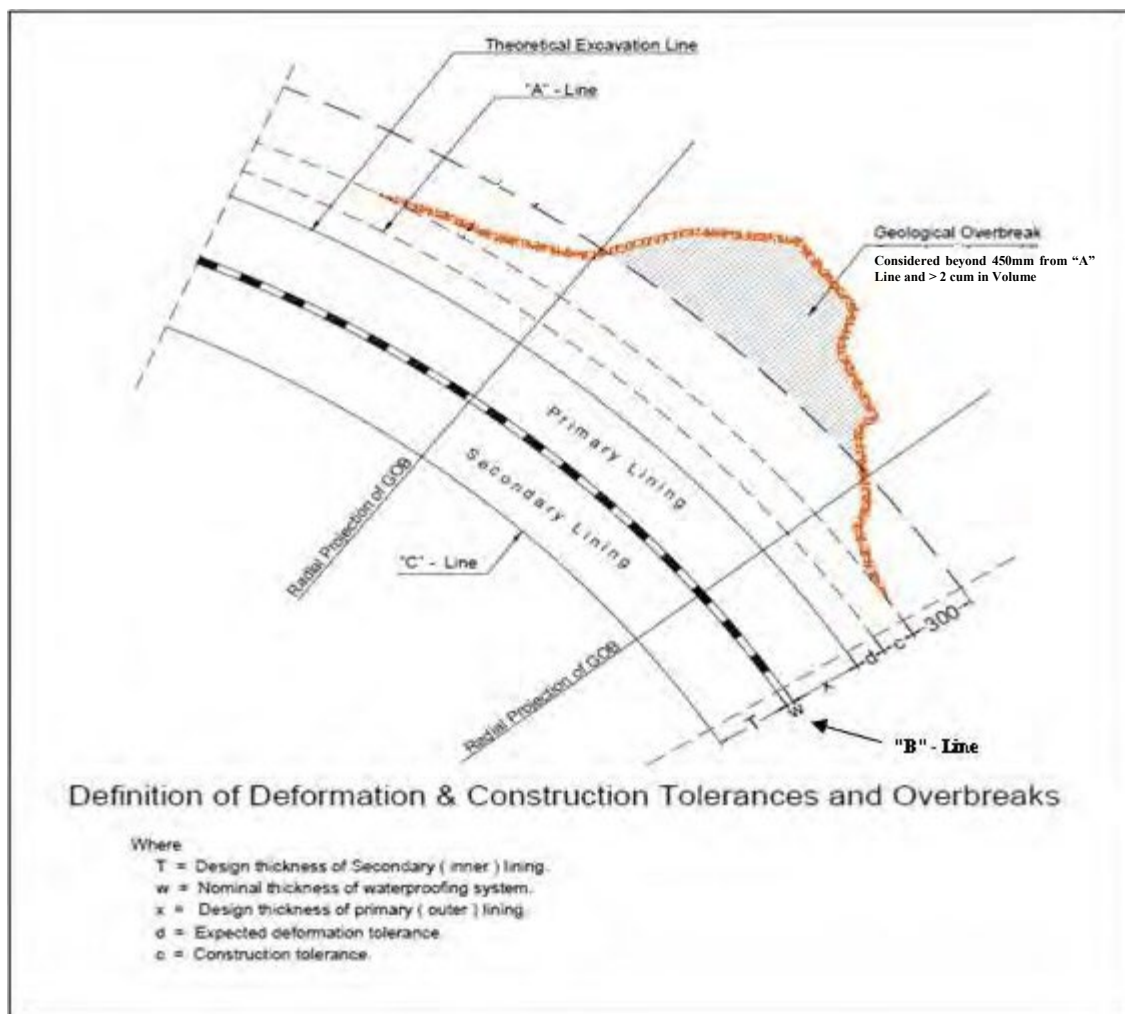

Figure: Definition

Typical cross section, minimum excavation lines and dimensions of excavations will vary for different Support Section Types required to be installed. Radial Deformation tolerances (δ) as mentioned in drawings shall be adjusted by the engineer to suit actual deformations as experience is gradually gained during excavation. The “A” Line shall accordingly be modified, and the Contractor shall be bound by all such adjustments.

8.5.2 Regulation for installation of Primary and Secondary Lining Support

- I. Primary Lining Support:** After scaling, entire excavated profile will be measured in situ with tunnel Profiler.

For the support classes with shotcrete and bolts only, the design thickness shall be applied directly on the excavated profile. Payment shall be made for the theoretical quantity increased by a thickness of 75mm only, based on the design drawings.

For the support classes with lattice girders/steel ribs, the excavated profile shall be placed with Shotcrete upto the "A Line". Thereafter, Design thickness of shotcrete and other supports shall be applied below "A Line", as indicated in the drawings.

For the case of the support types with Steel Ribs or Lattice Girders, the application of the shotcrete should respect the design thickness after the A line and reach to the corresponding B Line. In between the steel ribs or lattice girders, the shotcrete application less than the B line can be allowed, upon approval by the Engineer, respecting the following two criteria:

- A. Satisfy the shotcrete design thickness as per approved drawings
- B. Satisfy the waterproofing membrane waviness criteria

The finished profile of shotcrete shall be checked with tunnel Profiler and shall meet the tolerance for surface finish requirements for installation of waterproofing membrane (Chapter 4). Smoothing layer of shotcrete shall be applied as per drawings or as instructed by engineer.

- II. Secondary Lining Support:** Before application of water proofing membrane, Profile of existing shotcrete surface shall be recorded with tunnel Profiler to establish actual deformation occurred. Any eventual space between the shotcrete surface and "C" Line shall be filled with the inner lining concrete. This eventual space comprises of concrete volumes required on account of portion of radial deformation (δ) which did not occur, added to the volume of theoretical lining thickness.

The actual occurred deformations before the installation of the Final lining will be measured with the convergence target at the closest monitoring cross-section of each support class.

- 8.5.3** The drilling jumbo should be positioned as per precise survey reference points/lines and shall preferably be laser/total station navigated before it's usage in drilling etc.
- 8.5.4** The Contractor shall measure the excavated profile by means of a 3 D laser tunnel profiler after each round or as per direction of the Engineer. Excavation not shown on drawings, but which the Contractor considers necessary for his own purposes such as excavation from mucking pits, pump sumps, niche for vehicle parking/turning, drain ditches other than those shown on the drawings and specifications etc. for supply facilities shall only be carried out with the approval of the Engineer.

- 8.5.5** In case of pipe roof umbrella, the excess of excavation below the steel pipes will be filled with Shotcrete/final lining concrete as instructed by Engineer.

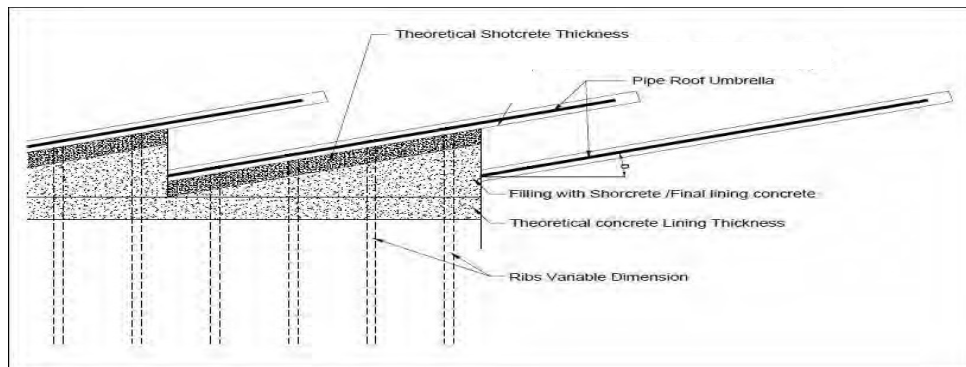

8.5.6 Tolerances for Lining:

- i. Secondary Lining: Finished surface of Secondary Lining shall not protrude “C” Line and be constructed within tolerance of $-0/+50$ mm radially (Negative value radially inward).
- ii. No reduction of the theoretical thickness of the inner lining is permitted unless approved by the Engineer. To achieve this requirement, no support elements such as primary shotcrete, rock bolts and steel ribs etc. shall penetrate the theoretical outer boundary of the inner lining.
- iii. In the area of the invert and the foundation beams, no rock parts or rock peaks shall protrude into the theoretical excavation line.

8.5.7 Tolerance for Excavation level on invert:

- i. For tunnel sections with no concreted invert arch the Contractor shall excavate the bottom level of the invert with an accuracy of -0 to $+100$ (Negative value radially inward) mm related to the theoretical excavation line of the invert.
- ii. If the bottom excavation level, after cleaning loose materials etc. is more than 100 mm below the designed theoretical excavation line, the Contractor shall backfill such areas up to the designed, theoretical level by means of sub-base material or as directed and approved by the Engineer.
- iii. For tunnel sections with a concrete invert arch no reduction of the designed, theoretical thickness of the concrete structure is permitted. Over excavation must be compensated with structural concrete/ shotcrete for the invert arch as specified. The inside face of a concrete invert arch may deviate not more than ± 50 mm in elevation from the theoretical cross section.

8.6 PROFILE CONTROL

8.6.1 Scope

- i. The Contractor is required to perform a careful and systematic checking of the final clearance of the primary tunnel lining in order to accommodate the designed nominal thickness of the secondary (inner) lining without interfering with the clearance requirements of the underground structure.

8.6.2 Method of Profile Control

- i. For profile control for the shotcrete lining see Chapter 11.
- ii. It is the Contractor's responsibility to ensure that the minimum clearance for the final (inner) lining as shown on the drawings is provided. On approval, the Engineer will issue instructions regarding the systematic checking of the geometry of the template during profiling operations.
- iii. The Contractor may prefer to use advance surveying techniques and data processing to establish the final clearance profile. In which case he shall define a method of marking out areas of deviation from the theoretical profile to be approved by the Engineer.

8.6.3 Execution

- i. The checking of the final clearance shall not proceed before the geotechnical measurements show that the radial displacements at any position of the tunnel have, in the opinion of the Engineer, largely stopped.
- ii. The final clearance profile after the completion of support works of the tunnel and after deformation as per this Clause shall conform to the minimum clearance profile as indicated on the drawings. Final control is required before water proofing system is applied.
- iii. In case of an existing under profile, the Contractor shall submit a proposal for the remedial works to the Engineer for approval.
- iv. No reshaping (re-profiling) of the tunnel support shall be carried out without the approval of the Engineer.
- v. Geotechnical measurements before, during and after the respective reshaping measures shall be carried out in compliance with the relevant design. The measurement points such as convergence bolts and/or extensometers shall be retained or substituted well in advance in order to establish "transfer - zero - readings".
- vi. Geotechnical measurement stations shall not be removed and abandoned without the approval of the Engineer.

8.6.4 Records

- i. Records shall be kept for each stage of the remedial measures executed.
- ii. The clearance profile i.e cross-sections of excavated profile shall be recorded at every meter of tunnel Chainage in longitudinal direction and at multiple points, 0.5 mtr apart along the periphery of the tunnel or as instructed by the Engineer.

The clearance profile shall be recorded by non-contact method (by manually or automatically) i.e by means of a “Tunnel profiler”. The checking of the clearance profile shall be done in presence of the Engineer.

- iii. For the shotcrete lining, the final checking of the clearance profile after completion of re-profiling and surface preparation in compliance with this Specification shall be done in presence of the Engineer.

8.7 SUPPORT FOR UNDERGROUND EXCAVATION

- 8.7.1** The provisional and permanent supports for the underground excavation shall principally consist of spot or pattern rock bolts, shotcrete, *lattice girder/steel ribs, forepoling and piperooting* supports as approved by the Engineer.
- 8.7.2** The Contractor shall install the support system as shown on the drawings or as directed by the Engineer in any part of the underground excavation based on rock conditions encountered during the work.
- 8.7.3** The Contractor shall employ a team of qualified geologists, who have adequate working experience in rock supporting work to act as support supervisor(s). The support supervisor(s) shall examine the rock conditions after each excavation advance and shall verify that the rock support system is installed as directed. The support supervisor(s) shall take necessary steps in consultation with Engineer in order to install additional supports or to stop further advance if, in his opinion, the conditions are unsafe. However, he shall have no right to cancel type or amount of rock supports previously directed by the Engineer. The support supervisor(s) shall be present at each heading face throughout the duration of underground excavation work.
- 8.7.4** The required supports shall be installed concurrently without delay during the process of excavation within the heading zones. In the rear zones additional supports shall be installed immediately after it is observed by monitoring that the supporting system previously installed is not enough to prevent further loosening of the material surrounding the excavation.
- 8.7.5** Shotcrete shall be applied, in accordance with the provision of relevant Sub Chapter of “Shotcrete”. The Contractor shall consider in his construction planning, that placing of shotcrete protection will be required immediately after blasting a round in conventional method of drill and blast.
- 8.7.6** The use of timber will not be permitted for tunnel supports in any form. However, the Engineer, in exceptional circumstances may permit use of timber for providing temporary supports, which shall be removed as early as practicable.
- 8.7.7** The Contractor shall keep on the site all necessary construction plant and equipment for installing rock bolts and shotcrete, ready for operation in the excavation heading zones during the entire excavation period.

8.7.8 The Contractor shall bear the whole responsibility for the proper and safe excavation. With the prior approval of Engineer, extra supports and special protection for the personnel when the conditions so require can be provided.

8.8 CLASSIFICATION OF UNDERGROUND EXCAVATION

8.8.1 Excavation

i. This section covers the description of rock mass types and rock classes relevant to the underground excavation with respect to the geotechnical properties of rock encountered and its behavior under the influence of tunnel construction. The terminology “rock” in this context shall also include soil conditions. The rock (ground) classes are derived not only from the rock parameters, but also from considerations of a number of external factors such as overburden, size of excavated section and length of round, driving sequence, ground water, water infiltration, results from geotechnical measurements, etc. which can essentially influence the classification.

According to Ö-NORM 2203 Classification, rock masses are divided into 3 main types which are A, B and C:

- A (Stable to over breaking): Stresses acting on rock mass do not cause major failures
- B (Friable): Disintegration due to structural weakness and/or lack of interlocking
- C (Squeezing): Strength of rock mass is exceeded to great depth; this type also includes rock bursts and swelling rock.

Type of support section required shall be based on based upon behavior of rock masses under load and monitoring the performance of underground excavations during construction.

ii. Rock (ground) classes are determined on the grounds of the appearance of the rock at the excavation face of the tunnel before the commencement of the respective excavation sequence. The results of geotechnical measurements under similar rock conditions shall be considered for prediction of deformations and for the determination of rock classes. The aforesaid classifications may not be applicable for a situation requiring multi drift excavation or locations encountering unexpected geological conditions requiring extra measures, for which the support system would be decided by the engineer depending upon the judgement of the rock type being encountered. In case of a drive subdivided into top heading - bench - invert excavation, the rock conditions of the top heading drive shall govern the classification. Following are the various types of Rock mass types and relevant rock mass behaviors.

Rock Mass Types	Rock Mass Behavior
A1 (Stable)	Minor deformations that decline rapidly, no spalling

Rock Mass Types	Rock Mass Behavior
A2 (Over breaking)	Minor deformations that decline rapidly; some spalling at the crown due to discontinuities
B1 (Friable)	Minor deformations that decline rapidly; structural weakness and blasting operations lead to loosening and the separation of blocks in the crown and upper wall
B2 (Very Friable)	Deformations decline rapidly; poor structural strength, little interlocking, high mobility of rock mass and blasting operations lead to rapid and deep loosening where unsupported
B3 (Rolling)	Excavation even in small cross sections leads to inflow of rock material; lack of cohesion and interlocking are responsible for insufficient stability
C1 (Rock Bursting)	Sudden release of energy leads to explosive rock failure
C2 (Squeezing)	Pronounced deformations that take long to decline; development of failure zones and plastic zones in plastic, cohesive rock mass
C3 (Heavily Squeezing)	Large deformations, rapid at the beginning, taking long to decline; development of deep reaching failure zones and plastic zones
C4 (Flowing)	Very low cohesion, low friction, soft and plastic consistency of rock mass; material will flow into the tunnel even through very small unsupported areas
C5 (Swelling)	Rock mass with mineral content that increases in volume by absorbing water, e.g. swelling clay-minerals, salts, anhydrite

iii. **SUPPORT SECTION TYPE**

- a. **The Support Section Type classes are the Rock Support Type classes given in the *Design Basis Report and Geotechnical Interpretative Report*, Section-VII-8:Tender Drawings and Documents.**
- b. The selection of Support Section Type and its adjustment shall be according to NATM or any other Controlled Convergence Method with observational feedback through 3D instrumentation and monitoring.

- c. The defined Support Section Type classes reflect the excavation system, the round lengths of each advance and the support requirements under consideration of the behavior of the rock mass.
- d. The defined Support Section Type classes are derived not only from the rock parameters, but also from considerations of a number of external factors such as overburden, size of excavated section and length of round, driving sequence, ground water, results from geotechnical measurements, etc. which can essentially influence the classification.
- e. The Support Section Type to be applied must be determined on site through Tunnel Face Mapping, 3-D Geo-logging at the excavation face of the tunnel before/prior the commencement of the excavation sequence.
- f. The Support Section Type at the face for each round shall be jointly agreed between the Contractor and the Engineer. In case of disagreement, the decision of the Engineer is binding.
- g. The results of geotechnical measurements and monitoring during tunnel construction shall be considered for prediction of deformations and for the determination of Support Section Type to be applied for future excavations.
- h. The behavior of the rock in a newly exposed round is time dependent, i.e. rock mass quality will decrease with the free span if no support is installed within a reasonable time. Accordingly, the maximum length of a round which can be excavated and supported in time is a criterion for the rock classification.
- i. Advance probing shall be carried out during tunnel excavation as and when required, as per instruction of Engineer. During advance probing, joint measurements & collection of data with contractor and Engineer shall be carried out.
- j. The selection of the Support Section Type shall be done jointly by Contractor and the Engineer in writing on agreed form-sheets. The classification record is a collection of all classification sheets, which shall be kept accessible for consultation and modification whenever excavation works are under progress/post construction phase. In case of disagreement, decision of the Engineer shall be binding.
- k. Notwithstanding the duties of the Engineer, the Contractor is solely responsible for the safety of the works under construction.
- iv. The Contractor will adopt the round length for each blast as instructed by the Engineer. The Engineer's decision to adopt a round length will depend on the behavior of rock mass in previous few rounds and the Support Section Type required to be installed in the round under consideration.
- v. **Variability for Each Support Section Type:** The defined Support Section Type includes some parameters variability (Round length, Support installations and locations) that should be managed during excavation using

the parameters like Q Value, RMR Value and Behavior in last few rounds. During execution, the Round length, Support installations and locations may vary on upside or downside from the given values, however only the net effect of all such variations shall be considered.

- vi. After each round, support section required shall be decided by the Engineer and Contractor on the basis of recorded observations. Geological face mapping sheet and Geo-mechanical classification of the excavation which face shall be elaborated by the Contractor and validated by the Engineer. Required Excavation and Support Sheet (RESS) shall be used as detailed in Annexure to Sub- Chapter 6: Instrumentation
- vii. Pull for next round will not be taken unless already excavated tunnel section in previous round has been supported to the satisfaction of Engineer.
- viii. After each blast, fumes shall be ventilated immediately within 15 minutes and scaling shall be done subsequently to remove loose or hanging rock pieces. Contractor's geologist at the time of scaling shall prepare a tunnel geological map registering joint sets, foliation, joint, infill materials, weak zones etc.
- ix. After completion of mucking, a period of 30 minutes and a man lift platform (Employer's half hour) shall be kept ready by the Contractor at the excavated face for engineer to check for any loose scaling, visually inspection and checking of rock classification carried out by Contractor and to come to a mutual agreement of the support section to be adopted. In case of any dispute, decision of Engineer shall be final.
- x. Immediately after decision on support section, supports shall be installed. The behavior of the rock in a newly exposed round will be time dependent, i.e. rock mass quality will decrease with the free span if no support is installed within a reasonable time. Therefore, contractor is required to respect the cycle time for timely support installation.
- xi. The Contractor shall document time taken for various activities, blast pattern adopted, charging of holes, blast sequence, geological mapping, scanning of tunnel profile before and after installation of support, actual support installed etc. in any excavation cycle on a shift basis and the record shall be got approved from engineer.
- xii. Additional excavation tolerance has already been inbuilt which shall be further established through a system of well documented monitoring observations, during excavation.
- xiii. The assignment of an individual support class shall always apply to the whole of the round length.
- xiv. For mixed face conditions, applicable support system shall be guided by the conditions representative of more than 50% of the mixed face. Engineer may direct to adopt a different support class also in such conditions. In case of any dispute, decision of Engineer shall be final.

8.8.2 Support System for Tunnels

- i. The Contractor shall understand and recognize the technical and design concepts of the NATM for the mined tunnels and shall appreciate the function and merits of each component of the tunnel support.
- ii. The type and amount of tunnel support to be installed immediately after excavation is directly related to the rock classification as established. The initial support system associated with the established Rock mass types and relevant rock mass behaviors classification is shown on the Bid Drawings for reference. However, as a consequence of variations from the anticipated rock conditions the initial support system as shown on the drawing for each rock mass type may require modifications and adjustment during construction as per agreement between the representative of the Engineer and Contractor. Decision of the Engineer shall be final.
- iii. The Contractor shall ensure that support elements will be installed or applied in such a manner and sequence as to prevent disintegration and loosening of the rock mass in front and around of the excavated tunnel.

8.9 EXECUTION**8.9.1 General**

- i. Prior to commencement of excavation, Tunnel portal, Tunnels, junction of tunnels with cross passages shall be strengthened as per construction drawings or as directed by Engineer.
- ii. All rock material projecting inside the minimum excavation line shall be removed.
- iii. All loose rock shall be removed from the underground construction sites and disposed off in the approved dump areas.
- iv. The Contractor shall constantly check the progress of excavation by means of Laser survey in order to avoid any substantial rectification of the already opened profile and eventual rearranging of the installed rock supports.
- v. Where excessive inflows of water occur at the heading face, the Contractor shall take all appropriate measures to execute the excavation work safely and properly including provision of extra supports and protection of workmen and any special equipment necessary for working in waterlogged conditions.
- vi. *Deleted.*
- vii. The Geological Report, as a part of these documents, contains the results of Geological studies carried out on this component of the Project.
- viii. The orientation of the tunnel as indicated on the drawings is subject to modification. It may be necessary to introduce slight shifting of the axes of the tunnel after additional information is available. The drawing showing the final

orientation will be prepared by the Contractor prior to start of work and he shall be required to execute the Work as per drawings or as directed by the Engineer.

- ix. Sheared or shattered rock zones, foliation shears, thick joints with gouge or other thick discontinuities may be encountered during excavation. Whenever shear zones and poor rock bands are encountered along the tunnel, Additional provisions of fore-poling, pipe roof, face bolting, etc. will be undertaken at once by the Contractor to avoid any cavity formation as shown on the drawings or as directed by the Engineer.

8.9.2 Method of Excavation

- i. The Contractor shall establish by trial blast and use drilling and blasting techniques, which will produce a smooth final profile a minimum of Overbreak and a minimum of fracturing of the rock beyond the minimum excavation lines. The techniques used shall always be subject to the Engineer's approval, who may direct several blasting tests to be undertaken by the Contractor to substantiate his proposed blast design.
- ii. Only controlled blasting techniques shall be used. It shall be performed as described below:
 - a. Pre splitting: Consists of drilling a single row of closely spaced holes along the final excavation perimeter. These holes are Lightly charged and simultaneously detonated before the main blast to produce a presplit crack, which limits the propagation of crack from the subsequent main blast, and in such a way, reduces damage in the rock beyond it. The blasting of the main excavation zone requires a reduced explosive charge in the line of hole nearest to the presplit line and a limit on the distance between the presplit line and the nearest line of main blast holes. The presplit holes shall be drilled deeper than the depth of the pull.
 - b. Smooth Blasting: Consist of drilling several closely spaced holes along the final excavation perimeter, placing light charges in the holes and detonating the charges simultaneously after the main blast. The outer line of drill holes for the main blast is set at an approved distance inside the final perimeter leaving an annulus of rock to be peeled off the damaged final excavation perimeter by the smooth blast The smooth blast holes are drilled, charged and blasted in the same tunneling cycle as the main blast.
 - c. Cushion Blasting: As special case blasting in which considerable air space of stemming surrounds charges in the holes and serves to reduce undesired blast effect on the final excavation perimeter.
- iii. During the progress of excavation the drilling and blasting pattern specifically the number and depth of holes, quantity, quality and distribution of explosives, shall be varied as necessary to suit the rock conditions encountered taking into consideration the information obtained from the probe/exploratory holes, the

actual drilling work (velocity, color of rinsing water, etc.) as well as the previous blasting results.

- iv. Only wet drilling will be permitted in order to reduce dust in the underground excavations.
- v. Perimeter drill holes shall be placed such that the over excavation beyond the minimum excavation line is minimized. The Contractor shall pay utmost attention to obtain a smooth and uniform excavated surface.
- vi. Should the entire length of most of the perimeter drill holes not be visible after each round of blasting, the Contractor shall make an adequate adoption in the blasting pattern used and submit it to the Engineer for approval.
- vii. The depth of a new round shall never exceed that which was determined and approved prior to commencement of basting. The Engineer may order reduction of the adopted round depth if the actual rock condition requires it.
- viii. Blasting of new round will not be permitted if no, or insufficient, personnel are available to perform the mucking and subsequent support work afterwards. This applies to Work before holidays, non-working weekends etc.
- ix. Blasting that may damage the rock beyond the required excavation lines or the tunnel installations will not be permitted. Any damage to, or displacement of the supports and any damage to, any part of the Works caused by blasting or any other of the Contractor's operations shall be repaired by the Contractor in a manner satisfactorily to the Engineer.
- x. No new round shall be blasted until the supports required within the heading zone have been installed.
- xi. All loosened material that is likely to fall shall be removed immediately following blasting, at frequent intervals during the progress of the Wonk, and finally during the clean-up prior to placing the final tunnel lining.
- xii. After excavating, the Contractor shall adequately protect the tunnel invert, surface from damage caused by the construction traffic, should small grain or broken excavation material be used for such protection, it shall be removed prior to placing the final tunnel lining. No vehicular traffic will be permitted over tunnel invert after removal of the protective material.

8.9.3 Excavation of Shaft

- i. The methodology for excavation of shafts in soil or soil & rock shall ensure safety during construction. Adequately designed support system to cater lateral earth pressure and hydrostatic pressure under worst drainage conditions shall be provided to safeguard long term stability. The Contractor shall submit a method statement for approval of the Engineer.

8.9.4 Cleaning of Excavation Surfaces

- i. Even prior to the removal of the bulk of the material loosened by blasting, the Contractor shall undertake scaling activities to clean the newly exposed rock

surface from loose rock fragments, dust and debris to permit if required, the application of the first lay of shotcrete.

- ii. Cleaning shall be done by directing a jet of water or air at the rock face. Compact washable rock shall be cleaned with compressed air water jets. Rock, which is prone to quick disintegration, swelling, heaving or is interspersed with clay filled fissures, shall be cleaned with compressed air only. The cleaning shall be done to the satisfaction of the Engineer.
- iii. The cleaning is separate from the cleanup of excavated surface required immediately prior to placing of the final lining described in Section of "Cement Concrete".

8.9.5 Tunnel Maintenance

The Contractor shall be responsible for maintaining the completed underground works throughout the construction and contract period. As part of this maintenance, remedial work shall be carried out when repairs are required to the structural or other systems or when grouting is required to stop water inflow.

- i. The Contractor shall monitor the tunnel support systems and record any damage to the support systems. If necessary, remedial action shall be taken with temporary propping, including evacuating the area and posting warning signs accordingly.
- ii. The Contractor shall, in addition to monitoring the support system, carry out regular maintenance of the underground works, including but not limited to bench marks, 3D monitoring, drainage and pumping systems, light bulb replacement, cleaning, water removal, water pipe maintenance, ventilation system signalling system, communication system, toilets, containers and emergency equipment, and all cabling, transformers and pipes for different purposes and its maintenance, and cable maintenance. Maintenance shall include all repair work required to maintain all equipment in working order.

8.9.6 Site Traffic on Final excavation levels

- i. (Formation level) for pavement construction shall be protected against any wear or deterioration of rock properties following site traffic by backfilling with rock material excavated in the tunnel or similar, to a minimum thickness of 0.5 meters. The access to the main drainage control shafts shall be possible at any time. These must be protected and marked on the side wall for later recovery.
- ii. Pounding water and traffic through pounding water for vehicles or pedestrians shall not be allowed.
- iii. Any deteriorated material shall be removed and replaced prior to pavement works as directed by the Engineer.
- iv. The backfill material used for protection purposes shall be removed in the main tunnel only until immediately prior to pavement construction works.

8.9.7 Site Traffic on Invert Support

To avoid damage to the Invert structures, these should be duly protected by giving a course constituted of excavated material and having an approximate average thickness of 0.5m. No site traffic shall be allowed to run on unprotected invert structures. Boulders larger than 100mm dia should not normally be used for this purpose.

8.10 DISPOSAL OF EXCAVATED MATERIALS

- 8.10.1** Muck/ Rubble generated from tunnel excavation/ hard rock cutting will be property of the Contractor and shall be taken away by the agency under proper authority letter from HORC authorized representative & shall be dumped outside of HORC limit by Contractor's own means, with all lead, lift, transportation charges, and other incidental charges etc complete as directed. The Contractor has to make his own arrangements for land required for dumping areas outside of Railway limit for muck/ rubble dumping at no cost to the employer.
- 8.10.2** Excavated materials, which are not suitable or are in excess of the permanent construction requirements, shall be disposed off outside HORC premises including labour, loading, unloading, transportation, all lead & lift, T&P, Taxes, octroi etc. complete in nominated dumping ground with prior approval from respective Departments/ Municipalities and Engineer in the course of the work.
- 8.10.3** The Contractor shall shape and trim the dumping areas of contractor and stockpiles to the lines and grades as directed or approved by the Engineer and shall provide for adequate diversion of existing water courses. The area over which the excavated material is to be disposed of shall be stripped of all vegetation. If the area is steeply dipping, precautions shall be taken to ensure stability of the material in the area, including base drainage and surface protection against erosion and providing retaining wall / gabions at wherever required. The material dumped shall be compacted, by movement of the dumping vehicles and grading as necessary, in layers not exceeding 0.5m in depth. It shall be the responsibility of the Contractor to remove any material from any slide that may occur in the disposal dump or its base and redispense the removed material properly to the satisfaction of the Engineer at his own cost. Prior to the commencement of excavation work the Contractor shall have prepared the disposal area to the satisfaction of the Engineer and the methods proposed for disposal shall also have received approval of the Engineer.
- 8.10.4** The Contractor shall be liable for any damage to Temporary or Permanent Works or to the property of third parties caused by poor drainage in the waste disposal or stockpile areas.
- 8.10.5** If additional areas are required for disposal of the excavated material, the Contractor shall propose such area for approval of the Engineer.
- 8.10.6** The Contractor shall ensure that no excavated materials are disposed off in the stream or at locations, where in the opinion of the Engineer these are liable to be washed away by the floods.

8.10.7 The disposal of the excavated material in the dumping area shall not damage the environment and will be regulated as per the norms of Government of India. In spite muck disposal area shall be suitably covered off with retaining structures. Before taking up such works the Contractor shall propose the construction methodology of retaining wall with RR Masonry/ gabions approved from the engineer.

8.11 ILLUMINATION

8.11.1 The Contractor shall install an adequate illumination system in the Underground works as stipulated in Section of "Site Installations and Services."

8.12 CONTROL OF DUST, SILICA AND NOXIOUS GASES IN UNDERGROUNDWORK.

8.12.1 The Contractor shall install and operate equipment for the control and monitoring of dust, silica and noxious gases in Underground Works as stipulated in Section of "Site Installations and Services".

8.13 COMMUNICATION SYSTEM

8.13.1 The Contractor shall install and operate the communication system between each heading face and entrance to the tunnel, shaft or cavern/chamber as stipulated in Section of "Site Installations and Services".

8.14 GEOLOGICAL MAPPING

8.14.1 The purpose of engineering geological mapping and follow-up is the documentation of rock and rock mass conditions as encountered during excavation. The documentation shall enable the verification of the suitability of the designed support and excavation measures, the prediction of rock mass conditions ahead as well as the interpretation of results of the geotechnical monitoring concerning ground deformations. After each blast, Mucking and scaling shall be done. After completion of scaling, a period of 30 minutes (Employer's half hour) shall be kept by the Contractor for engineer to visually inspect and check the rock classification carried out by Contractor and to come to a mutual agreement. In case of any dispute, decision of Engineer shall be final.

8.14.2 If stand up time of unsupported tunnel is very less, then the mutual agreement on rock classification may be required to be arrived at during mucking and scaling activities for early installation of the required support.

8.14.3 ENGINEER shall use mapping and related information along with the rock mechanics test and instrumentation monitoring results shall be used to optimize design of the final lining and rock reinforcement for the tunnel (s), shaft, cavern and chambers.

8.14.4 The Contractor always shall provide adequate lighting, proper ventilation, reasonable access, cleaning and washing of the walls and crowns for checking correctness of mapping by "ENGINEER" representative.

8.14.5 Documentation:

- i. The mapping and documentation of encountered geological conditions during the excavation shall be based on uniform legend and terminology for Rock Types / Rock Mass Types, Discontinuities, Jointing, Water seepage, Weathering, Rock Strength, Behavior of Rock Mass and other features which are needed to be described for complete record.
- ii. The documentation of the tunnels shall be based on the mapping of the face and the full periphery mapping method. The full periphery mapping method shall be applied for the permanent walls only. The frequency shall be adjusted to the variability of the encountered ground conditions. In case ground conditions are frequently changing within one round length each round shall be mapped. Each drive which is under construction shall be checked at least once a day. Support types will also be checked during periphery mapping studies.
- iii. Face mapping sheets: In general, the mapping shall be performed in a scale 1:100 and shall have a grid of 1 x 1 m for easier drafting, marked with "+". If necessary, details shall be mapped at other suitable scales. Using the uniform terminology, remarks can be stated directly on the mapping sheet or can be referred to the data sheet.
- iv. Data Sheets: The data sheet format shall be got pre-approved and shall consist of details like Tunnel, Location, Chainage, Excavation method, Name of mapping geologist, Date and Time, Rock Mass/Types, Discontinuities, Jointing, water, weathering, Behavior, General remarks etc.
- v. Vertical and Horizontal Sections: Based on the follow-up of mapping and data sheets, a vertical as well as a horizontal cross section shall be drawn, where the actual mapping results are incorporated continuously daily. The vertical section shall be located along the axis of the tunnel. The horizontal section must be fixed according to the chosen excavation cross section (full face, top heading - bench etc.). In case the tunnel is excavated by top heading - bench excavation the horizontal cross section shall be drawn on the level of the invert of the top heading. Horizontal and vertical scale shall be the same.
- vi. The position of the laser beams on the face as well as the steel rib connections may be marked as drafting guides.
- vii. Remarks can be stated directly on the mapping sheet or can be referred to the Face Mapping Sheet.

8.15 MEASUREMENT AND PAYMENT

8.15.1 General

- i. This is a lump sum contract hence no separate payment will be made for any of items separately. Bidders shall consider all expenditures in their total offered cost. However, all detailed measurement shall be recorded for all the works executed for the purpose of quality check, Preparation of completion/ as built drawings and future operation & maintenance.

Excavation occurring due to overbreak beyond “A” line shall not be paid and will be deemed to be included in the overall amount quoted for complete work under this contract. by the Contractor.

- ii. The Overall amount quoted for complete work under this contract. shall be deemed to include the entire cost of, but not be limited to the following:
 - A. The installation of pumps and pipes as well as their maintenance along the excavation for water inflows. In upward tunnel drives, the measurement of the water inflow shall be carried out 25 m behind the tunnel face. In downward tunnel drives, measurement shall be performed for the water inflow occurring within the last 5 m behind the tunnel face. There is no separate payment for power consumption shall be paid.
 - B. Provision of all labour equipment and materials required for the Underground excavation including drilling holes for blasting.
 - C. Developing and improving controlled blasting methods, blasting tests and performance of blasting.
 - D. Cleaning, washing, protection and maintaining excavated surfaces in satisfactory conditions and protection of tunnel invert until concrete lining is placed,
 - E. All enlargements and additional excavations or any temporary supports required by the Contractor for his construction methods,
 - F. In case of shafts, the entire cost of following items shall also be deemed to be included in the quoted amount for complete work under this contract:
 - a) Supply, transport, assembly and removal of equipment including hoisting equipment.
 - b) Use, Operation and Maintenance of Special equipments (such as raise climber etc.).
 - c) Drilling of pilot holes/ driving of pilot tunnels/ shafts.
 - d) Reaming.
 - e) Slashing.
 - G. Loading, hauling and dumping the excavated material on stockpiles, dumping area or points of incorporation into Permanent Works, shaping and trimming of the excavated materials in the dumping areas as specified, clearing of the stockpile areas, formation and maintenance of stockpiles, rehandling of suitable materials including segregating, grading, draining and drying of materials suitable for use in embankment construction or as backfill.
 - H. All delays during excavation work resulting from installation of rock

- supports and instrumentation measures as advised by engineer required by the Geo-technical conditions of the material encountered, irrespective of the distance from the heading face.
- I. Complying with all requirements of statutory laws and regulations relating to underground works and any restrictions resulting therefore obtaining all necessary permits and licenses for the purchase use storage and transport of explosives and other materials.
 - J. Surveying, setting out, checking of excavated profile, alignment and any subsequent rectification works resulting from undue or incorrect surveys provision of suitable equipment for and delays due to carrying out his work.
 - K. Furnishing, installation, operation, maintenance and removal of communication, illumination and ventilation system, observing safety precautions and measurement, monitoring of dust silica and noxious and Inflammable gases.
 - L. Recording and preparation of reports related to excavation progress and procedures. No separate remuneration shall be paid for geological mapping during tunnel excavation.
 - M. All works Involved with and any partial or short interruptions or inconvenience caused by the check surveys, performance of the rock mechanic test, installation and monitoring of instruments and geological mapping, for which no separate payment is provided elsewhere in these specifications.
 - N. Seepage/ingress of water suitably collected and drained away by gravity.
 - O. For Support Section Type where Forepoling is required, no separate remuneration for excavation beyond “A” line will be made and shall deemed to be included in the overall amount quoted for complete work under this contract.
 - P. For Support Section Type where Pipe roof is required, in Figure under Para 8.5.7. no separate remuneration for excavation beyond “A” line will be made and shall deemed to be included in the overall amount quoted for complete work under this contract.
 - Q. The payment towards the preparation of Muck disposal plan shall be deemed to be included in the overall amount quoted for complete work under this contract.
 - R. No separate compensation for the provisions for the start of tunnel excavation from the pre-cut is envisaged. The quoted amount for complete work under this contract shall include all costs required for the construction of the canopy structure (false portal), if required.

- S. No extra Payment will be made for hauling the excavated material to entry point of disposal area or entry point of permanent works where excavated materials are to be incorporated.
- T. Deleted.
- U. No separate payment shall be made for multiple drifting. No separate remuneration shall be paid for the removal of temporary support installed at the tunnel face or at the top heading invert.
- V. All delays during excavation work resulting from fore probing and grouting activities required to achieve the specified water tightness on the project.

8.15.2 Overbreak

- i. No payment shall be made for excavation occurring due to overbreak either avoidable or unavoidable.
- ii. Deleted.

8.15.3 Exclusions

- i. Rock supports required due to the Contractor not observing approved drilling and blasting techniques will not be included for payment.
- ii. No extra measurement for payment or payment will be made for:
 - A. Geological mapping as described in this chapter or performed at site.
 - B. Over breaks.
 - C. Any rectification Works resulting from incorrect surveys and 1 or blasting.
 - D. Over excavation including the works mentioned in section “Excavation Lines and Tolerances” above, required for Contractor's convenience. The concrete and grout required to fill such excavation shall also be at the Contractors expense.
 - E. Extra work or material required for repairing any damage to the tunnel invert caused by construction equipment.
 - F. Draining, shaping and trimming of the dumped material to the lines and grades as directed or approved by the Engineer.
 - G. Excavation of tunnels, other than those shown on the drawings carried out by the Contractor for his convenience and plugging thereof.

8.15.4 Royalties

Soil or rock spoils such as stones, boulder, pebbles, gravels etc. available from excavation, if are found suitable for use in works as per required specifications, can be used free of cost but the legally payable royalty and taxes are to be paid by contractor to the concerned authorities.

CHAPTER - 9

STRUCTURAL STEEL SUPPORT

9.1 GENERAL

- 9.1.1** The specifications described herein under relate to the work which includes all labour, materials, equipment and services required for the supply, handling, fabrication and installation of structural steel supports consisting of steel ribs and lagging, Lattice girders and Lining stress controllers to be carried out by Contractor in the underground excavation to the shape and dimensions as shown on the drawings.
- 9.1.2** Structural steel supports shall be installed either as complementary measure to the previously installed rockbolts and shotcrete when those prove to be insufficient to stabilize the excavation profile, or as immediate supports after excavation in the heading zone when the material encountered in the process of excavation requires such measures.
- 9.1.3** Steel ribs shall be furnished complete with bracing, bolts, nuts, washers, plates, tie rods, and other accessories necessary for installation of the supports. Horizontal or bent bracing in the invert may be required in some reaches.
- 9.1.4** Precast RCC or steel lagging shall be furnished separately for steel ribs.
- 9.1.5** The Contractor, if he considers necessary, may install temporary supports for his convenience and safety of his workmen / equipment during execution.
- 9.1.6** The supports shall be bent to the required shape by cold bending process only.
- 9.1.7** Minimum buffer stock for one-month quantity as per agreed work's programme of Re-Bars for (size decided by engineer) Steel ribs and lattice girders. However, towards work closure, the Contractor may use these quantities with prior approval of Engineer.

9.2 SUBMITTALS

- 9.2.1** Within 4 (four) weeks from the commencement date but before procuring the equipment or mobilization to the site, the Contractor shall submit to the Engineer, the description and drawings showing enough details of the layout, type and capacity of the equipment proposed for the fabrication of steel ribs.
- 9.2.2** At least 8 (eight) weeks in advance of the excavation of underground works being carried out on the site, the Contractor shall submit to the Engineer the schedule for fabrication of ribs and the method statement for erection to the engineer for agreement.
- 9.2.3** The Engineer reserves the right to require any additional information deemed necessary to be included in the submitted documents.

9.3 STANDARDS

- 9.3.1** The fabrication and installation of structural steel support shall conform to the following latest Indian Standard or where not covered by these Standard to the equivalent International Standards:

- i. IS: 5878 Code of practice for construction of tunnels conveying (Part-IV) water
- ii. IS: 800 Code of Practice for general construction in steel.
- iii. IS: 814 Covered electrodes for manual metal arc welding of carbon and carbon manganese steel.
- iv. IS: 816 Code of practice for use of metal arc welding for general construction in mild steel.
- v. IS: 1786 Specification for High strength deformed steel base and wire for concrete reinforcement.
- vi. IS 2062 Hot Rolled Medium and High Tensile Structural Steel
- vii. IS: 2502 Code of Practice for Bending and Fixing of Bars for concrete Reinforcement.
- viii. IS: 2751 Code of Practice for welding of mild steel Plain & Deformed Bars for Reinforced concrete construction.

9.3.2 In case of conflict between the above standards and the specifications given herein, the specifications shall take precedence.

9.4 NECESSITY & DETAILS OF STRUCTURAL STEEL SUPPORTS

9.4.1 GENERAL

- i. Steel support shall be installed to support crown and wall of underground excavation in all areas where, in the opinion of Engineer, alternative methods of rock supports like rock bolts and Shotcrete shall not provide adequate support either for construction safety or for permanent stability.
- ii. The exact requirement for steel supports in any area shall depend on actual conditions encountered as excavation progresses.
- iii. The design and details of the steel supports and steel supports accessories, precast RCC or steel lagging, including size, weight, spacing and method of installing in all parts of the excavation shall be subject to review / revision by the Engineer depending upon the rock conditions encountered.

9.4.2 STEEL RIBS

- i. The steel ribs shall comprise of I-beam or built up sections as shown on the drawings.
- ii. Rib splices shall be welded or made of bolted plates in such a manner as not to reduce the section moment of resistance.
- iii. Preferably one section size of steel rib profile shall be used for each portion of the Underground Works and the structural requirements due to rock conditions encountered shall be met by varying the spacing of the ribs as directed by the Engineer.

9.4.3 STEEL RIB ACCESSORIES

Steel support accessories shall include, but not be limited to, collar braces, tie rods, spreaders, liner plates, cribbing, blocking wedges, foot blocks, sills and invert struts which are fabricated from steel plates or sections or other steel products. Steel support accessories shall be used exclusively in conjunction with the steel ribs in the underground excavations and shall be used elsewhere when required by the Engineer.

9.4.4 *Deleted*

9.4.5 **Lattice girders**

The lattice girders shall be installed in a similar manner as steel ribs. Lattice girder segments shall have butt plates and the method of installation shall ensure tight connection of all elements. The accessories of lattice girders like plates, bolts, nuts and washers etc. shall be like steel rib accessories. Lattice girders shall be fully encased in shotcrete. Under no circumstance shall lattice girders be installed under unsupported ground.

9.5 **EXECUTION**

9.5.1 Steel ribs shall be cold bent with an allowance of one percent to the shape as shown on the drawings. Re-shaping of the bent ribs at the place of installation may only be undertaken with Engineer's consent and only if the material properties would not be impaired.

9.5.2 Excavation of the underground works shall be completed true to the lines shown on the drawings before installation of steel ribs. The steel ribs shall be placed at the minimum excavation line and at spacing as shown on the drawings or as determined by the Engineer.

9.5.3 Concrete blocks or steel profiles shall be provided as footing for the steel ribs. Use of timber, as foot blocks shall be strictly prohibited. The footplates shall be of enough size and rigidity. If required, the legs of the ribs shall be anchored to the rock by the rockbolts. Where invert bracing is required, it shall be fixed securely to the lower legs of the rib in such a way that buckling is not induced in the steel rib by the presence of such bracing. In case of invert overbreak, the void between the rock and the lattice girder footing shall be filled with pre-cast concrete slabs / blocks.

9.5.4 Steel sections and plates shall be cut, welded, bolted or otherwise provided to the shapes and dimensions indicated on the drawing or as directed by the Engineer.

9.5.5 Immediately after placing the ribs in a correct position, they shall be interconnected and braced by mean of steel bars or beams in order to prevent any displacement and to maintain spacing. Use of timber spreaders shall be strictly prohibited.

9.5.6 Immediately prior to concreting, casting or spraying, the arches, ties and struts shall be rendered clean and free from deleterious matter.

9.5.7 The space remaining between the outer flange of the steel rib and the rock surface shall be backfilled immediately, after the rib has been placed, with concrete or shotcrete over the entire circumference of the steel rib in order to provide uniform load distribution. In over excavation, the bulk of the void space may be filled with concrete / shotcrete.

- 9.5.8** The Contractor shall duly record the position of all steel ribs installed in order to facilitate drilling operations later on for grouting/drainage purposes etc. Their position shall be marked on the finished concrete lining surface.
- 9.5.9** Blocking and wedges used to set the steel may be steel, or concrete blocks.
- 9.5.10** Structural steel supports be maintained in position by the Contractor after installation. Any steel ribs installed improperly or damaged by the Contractor's operations shall be adjusted, repaired or replaced as appropriate by the Contractor without delay after notification by the Engineer.
- 9.5.11** *Deleted.*
- 9.5.12** During work the Contractor shall maintain a sufficient reserve of steel ribs complete with all accessories on each work site.

CHAPTER -10**ROCK BOLTS, WIREMESH, FOREPOLING AND PIPEROOFING****10.1 GENERAL**

10.1.1 The specifications described herein under relate to the Work which includes all labour, material, equipment and services required for the supply, installation, testing and monitoring of rockbolts, pipe-roofs etc. and also the supply and installation of wire mesh and mesh anchors as specified herein or as shown on the drawings.

10.1.2 Rockbolts, pipe roofs etc. shall be furnished complete with all accessories and other materials necessary for their installation, stressing and grouting.

10.1.3 If directed or approved by the Engineer, the Contractor shall supply and install flat steel plates or rolled steel sections to connect together two or more rockbolts.

10.1.4 The Contractor shall maintain on site or have immediately available at least one month buffer stock as per agreed work programme of any of the support elements i.e. Wiremesh, Self-Drilling bolts, Fiber glass bolts or any other specialised bolts required according to the rock mass classifications and as per drawings. However, towards work closure, the Contractor may use these quantities with prior approval of Engineer.

10.1.5 STANDARDS:

The specifications, production, working etc. shall conform to the following latest Indian Standards or where not covered by these Standards, to the equivalent International Standards. The list is for guidance purpose only. The Contractor shall abide by all codes/regulations/ specifications as are deemed necessary for the satisfactory completion of work.

i. Indian Standards:

- a. IS: 1786 – 1985 (Reaffirmed 2000), Specification for high strength deformed steel bars and wires for concrete reinforcement
- b. IS:11309 – 1985 (Reaffirmed 2001), Method for Conducting Pull-Out Test on Anchor Bars and Rock Bolts
- c. IS:1611 – Steel Tubes for Structural purposes- Specification

ii. American Society for Testing and Materials (ASTM):

- a. ASTM A36/A36M - Standard Specification for Carbon Structural Steel
- b. ASTM C150 - Standard Specification for Portland Cement
- c. ASTM C494 - Standard Specification for Chemical Admixtures for Concrete
- d. ISRM - Doc.2, Part 1 "Suggested Method for Rock-bolt Testing".

10.2 SUBMITTALS.

10.2.1 At least 8 (eight) weeks prior to the commencement of excavation works, the Contractor shall submit, to the Engineer, the details of equipment to be used for testing and installation of Rock bolts / Pipe roofs / wire mesh etc.

10.2.2 The Engineer reserves the right to require any additional information deemed necessary to be included in the submitted documents.

10.2.3 Test reports of tensile strength tests and pull out tests, routine pullout tests (IS:11309) shall be submitted immediately within 3 hours after the test is carried out.

10.3 GENERAL

10.3.1 For the sake of convenience, the terms used in the Chapter are defined as follows:

- i. Reinforcement Element is a general term of rockbolts, pipe roofs, wiremesh etc.
- ii. Rockbolt is a stressed (or tensioned) reinforcement element consisting of a rod, grouted anchorage, and plate and a nut for stressing by giving torque to the nut or for retaining tension applied by direct pull. It is synonymous with “active rock anchor”.
- iii. Individual rock bolting refers to the installation of reinforcement elements in localized area of instability or weakness as determined during excavation. It is synonymous with spot bolting.
- iv. Pattern Rock bolting refers to the installation of reinforcement elements in a regular pattern over the excavation surface.
- v. Water expandable bolts: High-pressure water shall be injected into the steel tube, which causes the steel tube to expand and to form it to the irregularities in the drilled hole.
- vi. The reinforcing bar steel used shall be from sources as indicated in the Section – Material for construction. Corroded steel bars shall not be used.

10.3.2 The following types of reinforcing elements are proposed to be used:

- i. SN Bolts: Resin-grouted and cement grouted.
- ii. Water expandable bolts.
- iii. Self-Drilling anchors as Rock bolts or Fore Poles.
- iv. Pipe roofing umbrella.

10.3.3 The type, length, diameter, inclination and pattern of the rockbolts shall be as shown on the drawings or as approved by the Engineer. The Contractor shall provide manufacturer's test certificate for all batches of rockbolts supplied. At least 5 samples shall have been tested for tensile strength until failure from each individual batch of rock bolts which is marked with the same manufacturer's identification number. All the results of the tensile test shall comply with the specified data of the manufacturer.

10.3.4 Bearing plates shall conform to IS 2062 and be flat or dished steel plates having minimum dimensions suitable to carry take full load for Rock bolt is installed (Atleast

1 plate of 200x200x12 for 32mm dia bolts and 1 plate of 150x150x10mm for 25mm dia bolts). The washers to be used shall be bevel or hemispherical.

- 10.3.5** All surfaces of the bearing plates, nuts, washers and wedges, and threads on the projecting ends of rockbolts shall be protected and lubricated with rust preventive compound.
- 10.3.6** Corroded bolts or steel or other elements shall not be used.
- 10.3.7** When rockbolts are used in conjunction with wire mesh, the mesh shall be connected firmly to the bolts by means of extra steel plates and nuts.
- 10.3.8** Wire mesh shall not be placed between rock and the bearing plate of the rockbolts. Additional plates shall be provided for this purpose.
- 10.3.9** Couplers may be required for the bolts. When coupler is used, the threading in the bar shall not reduce the effective diameter of bar. Coupler itself should be able to transfer at least 125 % of the yield load of the bar. Couplers shall not be permitted for rock bolts less than 4m in length.
- 10.3.10** Minimum one PVC centralizer per rock bolt shall be provided. In long rock bolts, one centralizer at every 6m shall be provided along the length of the bolt.

10.4 TESTING AND MONITORING OF ROCKBOLTS / ROCK ANCHORS.

10.4.1 The Contractor shall furnish atleast two sets of testing equipment including hydraulic jacks, fixing device, hydraulic pump with pressure gauge / manometer, extensometer and all necessary accessories. The testing equipment shall be capable of stressing the largest diameter rockbolt to the yield stress of the bolt.

10.4.2 Proof Tests

- i. A detailed test program set up on basis of above-mentioned document shall be approved by the Engineer prior to all testing work.
- ii. Specific deviations from the ISRM suggested method shall be approved by the Engineer.
- iii. A test report shall be issued immediately after completion of the tests. It shall be submitted for approval to the Engineer.
- iv. For each type of rock bolt submitted information shall comprise:
 - A. type of bolts
 - B. testing equipment
 - C. location and installation records
 - D. Applied testing loads and records of deformation
 - E. Otherwise the evaluation of test results as specified in ISRM's document
 - F. Interpretation and suggested action for failed pull-out tests

- v. Proof tests shall be carried out for all types of bolts to be used for this project prior to the commencement of tunnelling to demonstrate the effect and the A service capacity of the bolts in the field.
- vi. The tests shall be performed in similar geological ground conditions as expected during tunnel drive. The location of the bolts to be tested shall be selected by the Engineer.
- vii. A minimum of five bolts of each type shall be tested. Depending on the testing procedure and the test results the Engineer may require further bolts to be tested.
- viii. Adequate testing equipment, as specified in the above mentioned ISRM document shall be provided to record bolt elongation, movement of the bolts and tension forces.
- ix. The maximum load to be applied shall be the bolt's yield load or as otherwise approved by the Engineer.

10.4.3 Testing during Tunnel Driving:

The Engineer will select rock bolts for testing of production bolts. For each type of rock bolts five bolts will be selected from the first 100 bolts placed in the tunnel. From the remaining bolts five per 500 bolts will be selected for testing purpose. The testing force to be applied shall be equal to 80% of the rock bolt yield load.

- i. Bolts which fail the tests, or which are pulled out shall be replaced.
- ii. For each failure, the Engineer shall require further bolts to be tested in the vicinity.
- iii. Otherwise as per relevant clause above.

10.4.4 Grout mortar: Prior to acceptance tests of rock bolts, tests with available cements and sands shall be carried out to determine an appropriate mix design to achieve the specified strength and a proper workability in association with the grouting equipment used. Additives will be used to improve workability. The grout mortar shall be tested on cubes 5x5x5 cm. The cubes shall be cured in water. Five numbers of cubes shall be prepared for each compressive strength test. The resultant strength is the average evaluated from the three remaining values after elimination of the highest and the lowest. During construction, cube sample shall be taken weekly at each five bolts drive from the grouting hose at the nozzle. Preparation and evaluation shall follow the procedure as described above.

10.4.5 If any rockbolt fails due to improper workmanship or defect in materials or due to any reason whatsoever, the Engineer may order a test on all adjacent rockbolts and all rockbolts so failing shall be rejected, replaced and retested.

10.4.6 The bolts and anchors shall be checked for their straightness Tolerance with ± 1 mm.

10.4.7 The pullout trials shall be conducted in conformity with IS: 11309.

10.4.8 Further sampling and testing for quality control will be got done as directed by engineer at contractor's cost.

10.5 DRILLING HOLES & PREPARATION FOR INSTALLATION

- 10.5.1** Holes for rockbolts shall be drilled as specified herein and in accordance with the provisions set out in Section of “Drilling and Grouting”
- 10.5.2** The minimum diameter of each hole shall be as specified below or as directed by engineer:
- i. Rock Bolt of 25mm dia: Hole dia 45mm with coupler and 38mm without coupler
 - ii. Rock Bolt of 32mm dia: Hole dia 64mm with coupler and 50mm without coupler
- 10.5.3** The length of drill hole shall be such as to receive the specified rockbolt and to provide for its satisfactory anchorage.
- 10.5.4** After drilling, each hole in compact, washable rock shall be washed out with clean water and cleaned by blowing out all drill cuttings and debris with compressed air. The holes in rock, which tend to swell or are interspersed with clay filled fissure shall be cleaned with compressed air only. The compressed air shall not contain any oil or other material preventing the bond.
- 10.5.5** Prior to installing the rock bolts, which will be stressed, the rock surface adjacent to the hole shall be prepared for the bearing plate. Only bevel washers shall be used which shall be placed between the bearing plate and the nut, or dished bearing plate and hemispherical washer used to ensure uniform bearing.
- 10.5.6** If a rock bolt is not installed immediately after drilling the hole, the hole shall be washed and cleaned as stipulated above, immediately prior to installing the rockbolt.
- 10.5.7** Fresh holes, as directed by the Engineer, shall be drilled by the Contractor at his expense to substitute such holes as have been drilled out of place or alignment.
- 10.5.8** The rock surface around the drilled holes to receive the bearing plate shall be chipped smooth or be covered with a smooth quickset cement pad.
- 10.5.9** All bolts within 10 m of a blasting operation shall be retightened to the specified torque within 4 hours after each blast. If it is found that any bolt does not take the required torque without anchorage slip, a new bolt shall be installed in the immediate vicinity of the unsatisfactory bolt.

10.6 Installation Records

Comprehensive records about details of the installation of rock bolts during drivage, such as grout consistency, drilling depth, length and type of rock bolts, deviations from the theoretical position, type and time of grouting, time of tightening, special observations, etc. shall be kept for each round by the Contractor and countersigned by the Engineer's supervisory personnel. Copies of these records shall be submitted to the Engineer.

10.7 ROCK BOLT RESIN-GROUTED (SN Bolt)

- 10.7.1** Rockbolts shall consist of deformed steel bar of 25 mm or 32 mm Ø (Grade Fe-500D conforming to IS 1786). Each bolt shall have one end chamfered and the other end threaded with a coarse thread over a length of 200 mm.
- 10.7.2** After the hole is drilled and cleaned, fast setting resin cartridges shall be placed in the fixed length of the drill hole at bottom as determined by the pull-out tests and slow setting resin cartridge in remaining length of drill hole. These cartridges shall be tamped with the bolt for proper packing. The rock bolt shall then be advanced and rotated steadily through the capsules at the rate recommended by the manufacturer by means of a pneumatic tool and a coupling attached to the threaded end of the bolt. The rotation shall be continued after the bolt has been fully inserted for a further 30 seconds. Bolt shall be stressed by torqueing/jacking, by means of an approved and regularly calibrated stressing device to the level as directed by Engineer. The bolt shall be stressed before setting time of slow setting resin cartridges as suggested by manufacturer. The Contractor shall demonstrate the resin cartridges used satisfy the specified strength requirements of the bolts to the satisfaction of Engineer, before use.
- 10.7.3** Bolts shall be thoroughly cleaned before being placed in the drill hole.
- 10.7.4** The minimum capsule diameter should be proposed for each drill bit dimension, considering that the hole must be fully filled with resin. The drill bit diameter should be defined by the manufacturer, however, as guidance, for a 32 mm resin capsule diameter, the drilling should not be more than 38 mm.
- 10.8** **ROCK BOLTS CEMENT GROUTED (SN Bolt)**
- 10.8.1** Rockbolts shall consist of deformed steel bar of 25 mm or 32 mm Ø (Grade Fe-500D conforming to IS 1786). Each bolt shall have one end threaded with a coarse thread over a length of 200 mm.
- 10.8.2** Anchor bars/anchor bolts shall be thoroughly cleaned before being placed in the drill hole. The hole shall be filled with grout constituting 1:1 cement/sand mix with low water cement ratio, by inserting the grout hose to the full depth of the hole and withdrawing as the grout is pumped in. The nozzle shall be kept buried in the grout as the pipe is withdrawn so that air is displaced as the hole is filled. The bolt is then pushed into the hole. Admixtures for fast setting and low shrinkage may also be required.
- 10.8.3** In case of coupled rock bolts, partly collapsed boreholes, or major water- flow from the borehole, grouting may be done after installation of the bolt (post-grouting). The hole is then grouted by a special attachment which allows the mouth of the borehole to be sealed whilst the grout is pumped in. Air is displaced from the hole via a tube which is attached to the full length of the rock bolt as it is installed. Grout is then pumped in and the hole can be seen to be full, when grout escapes from the end of the tube.
- 10.8.4** The nut of the grouted rock bolts shall be tightened not later than 12 hours after installation to achieve a force at the anchor plate of approx. 20 KN. This force shall be applied by a calibrated torque wrench.
- 10.9** **SWELLEX TYPE WATER EXPANDABLE BOLTS**

- 10.9.1** Water expandable rock bolts shall be manufactured from a mechanically reshaped steel tube with bushing pressed onto the ends, sealed through welding. The bolt shall have an expansion pressure rating of 300 bar and wall thickness of minimum 3mm. The bolt shall have separate protective coating (zinc epoxy/bitumen/plastic/polymer) that isolates and actively protects the steel. The lower bushing shall have a flange to hold a face plate in place. High-pressure water (about 300 bars) shall be injected into the steel tube through a hole in the lower bushing. This causes the steel tube to expand and to form it to the irregularities in the drilled hole. A 200 mm long sleeve tube made of steel prevents the bar from swelling at the drill hole mount. As the swelling process occurs, the lower part of the steel tube shortens, pulling the face plate firmly against the rock face. The water pressure is released after installation and the water allowed draining out of the expanded steel tube. The drill hole diameter has to be adjusted to suit the size of rock bolt according to the Manufacturer's recommendations. The water expandable rock bolts shall have characteristic minimum breaking load of more than 150 KN and shall undergo up to 10% minimum elongation before failure.
- 10.9.2** All face plates, washers and other accessories used shall be from original manufacturer of the bolt. Face plates shall be spherical dome type.
- 10.9.3** The bolts shall be supplied, installed and tested as per recommended procedure of the manufacturer. Standard pull testing shall be done with pull tester along with its other parts as manufactured by OEM. Additional bolt material testing, if required, shall be carried out as determined by Engineer in charge depending on site conditions.
- 10.10 SELF DRILLING ROCK BOLTS**
- 10.10.1** This is a high-grade (Yield load more than equal to 230KN) hollow core seamless steel bar with continuous threaded surface for mechanical coupling. In addition to hollow core seamless steel bar, other parts of the assembly consists of Hexagonal nut, bearing plate, extension couplings and sacrificial drill bit. Before and during installation, thread ends will be kept cleaned to allow hex nut and coupler threadability. Construction and drilling shall be as per manufacturers guidelines.
- 10.10.2** SDA Bolts shall have outer dia of minimum 32mm and inner diameter less than equal to 18mm. Length of rod to be procured shall be decided in agreement with engineer.
- 10.10.3** Bearing plates shall allow articulation of 5 to 7 degrees in all directions.
- 10.10.4** Drill bit to be used shall be selected according to installed length of bolt, geology and size of bolt.
- 10.10.5** Couplers and Nuts shall exceed the tensile strength of bars by minimum 20%.
- 10.10.6** The bolt shall be grouted according to manufacturer's guideline (to a minimum pressure of 6 bars) with manufacturer's grout material supplied along with bolt. Alternatively, grout mix (M-35 grade) may be prepared using OPC 53 cement and sand having maximum particle size of less than 0.3mm. Grout mix shall have a water cement ratio less than 0.4 and shall contain PC based super plasticizer (Minimum 2%) and expanding

plasticizer (allowing upto 3.5% expansion in neat cement) from reputed manufacturer. Admixtures containing chlorides and alkali shall not be used. Face of the Bolts shall be sealed off with GP2 or Similar rapid setting grout to prevent grout leakage during build-up of pressure.

10.10.7 These bolts may also be used as forepoles.

10.10.8 All accessories of self-drilling rock bolts shall be suited to the main anchor rod type and shall be procured from original manufacturer of the bolt.

10.11 WIRE MESH AND MESH ANCHORS

10.11.1 WELDED WIRE MESH

- i. Welded wire mesh shall be installed in surface and underground excavation as reinforcement for shotcrete, usually in combination with rockbolts. It may also be used with steel ribs, when it shall be laid over the outer flange of the rib and pinned or fixed to the excavated surface between the ribs where necessary.
- ii. Welded wire mesh shall conform to the requirements of IS: 1566. The fabric shall have a minimum square mesh of 150x150x6 or 100x100x4, made of wires having a strength not less than 480 Mpa and diameter 3 to 5 mm or as directed by engineer.
- iii. Where possible, the welded wire mesh shall be placed at the same time as rockbolts are installed. It shall not be placed between the rock surfaces and bearing plates of rockbolts but shall be placed over the heads of rockbolts and fastened to them by separate plates and nuts. Sufficient intermediate mesh anchors, or if directed by the Engineer, additional rockbolts, shall be placed to ensure that the mesh is drawn close to the excavated surface so that when shotcrete is applied subsequently, the mesh neither sags nor vibrates excessively and impairs the effectiveness of the shotcrete.
- iv. In case the welded wire mesh is placed at such locations where rockbolts have not been provided, wire mesh anchors of a type acceptable to the Engineer shall be used to secure the edges of wire mesh tight to the rock surface to provide anchorage at overlaps and to provide intermediate support. The wire mesh anchors shall have a minimum length of 450 mm.
- v. The use of wooden pegs and pins for fastening the wire mesh to the rock surface will not be permitted.
- vi. Welded wire mesh shall be firmly stretched between the rockbolts. Care shall be taken to ensure that air pockets are not formed behind the wire mesh, when used as reinforcement for shotcrete. Overlaps in the wire mesh shall not be less than 300mm.

10.12 PRE-EXCAVATION SUPPORT MEASURES

10.12.1 In general, all poor reaches shall be supported by regular supporting measures (Rock reinforcement, shotcrete, Steel Ribs, Lattice Girders, pre-injection grouting etc.) as specified in drawings. However, certain ground conditions may require tunnel support

ahead of face before it's excavation. For such situations, **after completion of Pre-Excavation grouting ahead of face**, the advance support measures as described below shall be implemented if required at site as per direction of Engineer.

- 10.12.2** Grouting of pre-excavation support measures (Forepoles, Piperroof and Fiber glass bolts):
- i. OPC 53 / 53Scement shall be used for grouting.
 - ii. Cement grout shall attain minimum M20 strength.
 - iii. Viscosity of grout shall be such that it shall not leak down from vertical holes in the bolt/plate and adheres immediately to rock.
 - iv. Water cement ratio of cement grout shall be in the range 0.50 to 0.75 as decided by Engineer and 1.5% PC admixture shall be used to increase flowability of grout..
 - v. Admixture shall be added to achieve the workability required for the operation and prolong the initial set to minimum 1 hour.
 - vi. Starting pressure for grouting of cement grouted bolt and forepoles shall be 10 bars and grouting shall be continued till sufficient grout take has been accomplished throughout its length.
 - vii. Face of the Bolts/forepoles/pipes shall be sealed off with GP2 or similar grout to prevent grout leakage during build-up of pressure..
 - viii. Sufficient numbers of grouting packers shall be available at site to grout same stage of 6m in multiple pipe roofs. Packers will not be disturbed before final setting time of grout.
- 10.12.3 FOREPOLING:** Fore poles shall be 25/32 mm diameter self-drilling anchor bars or SN bolts or pipes having outer dia less than 48mm of this sub chapter having length of 6 meters or more. The fore poles shall be placed along periphery of the tunnel inclined at angle and pipe spacing (mentioned in drawings), at the heading face and cement grouted in place as directed by the Engineer.
- 10.12.4 PIPE ROOFING:** When ground conditions are such that face cannot be supported by forepoling, then pipe roofing shall be required to be implemented. Pipe roofing consists of high tensile seamless steel pipes(Having a minimum outer diameter of 76mm and a minimum yield load of 1200 KN) conforming to IS: 1611 (Maximum 24 m long) placed along periphery of the tunnel in one or two layers, each layer inclined at angle and pipe spacing (mentioned in drawings) at the heading face or as directed by the Engineer. Engineer may require use of Self drilling 76mm dia pipes. Other pipes of larger diashall be connected to each other by nipple coupling or squeezed connection or seamless butt-welded producing a leak proof connection. Standard threaded connection shall not be permitted. The cement (OPC 53 or other) grouting of pipes shall be done. In case of perforated pipes grouting shall take place in stages using packer in each stage and starting at deepest location first. Sacrificial ring bits should be used. AT-casing system

(or similar) shall be used and orientation of drilling shall be guided by means of equipment installed on the jumbo boom.

10.13 FIBRE GLASS BOLTS

10.13.1 Fibre glass bolts shall be 32/15 configuration with load carrying capacity of more than 300 KN and shall be grouted immediately after installation.

10.13.2 Fibre glass bolts of other configuration or strength may be used by contractor with approval of engineer.

CHAPTER -11

SHOTCRETE

11.1 SCOPE OF WORK

- 11.1.1** The specifications described herein under related to the work, which includes all labour, materials, equipment and services required for the shotcrete work (plain and fiber reinforced) to be carried out by the Contractor under this Contract.
- 11.1.2** All shotcrete work shall be carried out in accordance with guidelines specified in this section. The shotcrete work shall be performed to the dimensions as shown on the drawings or as otherwise directed by the Engineer.
- 11.1.3** *Compressive strength of shotcrete shall be met by compression testing of cylindrical cores extracted from Tunnel wall. The sample prepared for testing shall have a 100mm length and 100mm diameter (Equivalent of a cube).*
- 11.1.4** The approval given by the Engineer to the Contractor's equipment of their operation or of any construction methods shall not relieve the Contractor of his full responsibility for the proper and safe execution of Shotcrete work or any obligations under this Contract.

11.2 SUBMITTALS

- 11.2.1** Within 28 days from the commencement date, but before procuring or mobilizing to the site, the equipment, the Contractor shall submit to the Engineer, updated and detailed plans and descriptions, of the following:
- i. Batching and Mixing Equipment
 - a. Description and details of the equipment, which the Contractor intends to use to determine and control the quantity of shotcrete ingredients and mixing thereof into uniform mixture. This shall also include automatic dosing equipment for various admixtures and fibers. All equipments shall be capable of monitoring and recording the dosage during production process.
 - ii. Placing Equipment
 - a. Full details, of the equipment to be used for placement of shotcrete (Robotic Shotcrete machine) and details of standby equipment.
 - iii. Details of methods and equipment which the Contractor proposes to use to control the temperature of aggregates and water during extreme hot and cold weather conditions.
- 11.2.2** At least 28 days in advance of any shotcrete work being carried out on the site, the Contractor shall submit, to the Engineer the following:
- i. Notifications of any admixture and Pozzolana, which the Contractor proposes to use, manufacturers thereof and information about the chemical names of the principal ingredients and the effect of under or over dosage.

- ii. Description and details of methods which the Contractor proposes to adopt for Shotcrete.

11.2.3 The Engineer reserves the right to require any additional information deemed necessary to be included in the submitted documents.

11.3 STANDARDS

11.3.1 The Shotcrete materials, production, methods of application, testing and admixtures shall conform to the following latest Indian Standard or, where not covered by these standards, to the equivalent International Standards.

11.3.2 Indian Standards

- i. IS: 456 Code of Practice for Plain & Reinforced concrete.
- ii. IS: 269 Specification for ordinary Portland cement.
- iii. IS: 383 Specification for coarse and fine Aggregates from natural source for concrete.
- iv. IS: 516 Method of test for Strength of concrete.
- v. IS: 9012 Recommended practice for Shotcrete.
- vi. IS: 2645 Specification for Integral cement water proofing compound.
- vii. IS: 9103 Concrete Admixtures.
- viii. IS: 12269 Specification for 53-grade ordinary Portland cement.
- ix. IS: 15388 Silica-Fumes.
- x. IS:7861 Code of practice of extreme weather concreting.
- xi. IS: 1199 Methods of Sampling and Analysis of Concrete.
- xii. IS: 5878 Code of Practice for Construction of Tunnels.

11.3.3 International Standards have been mentioned at relevant locations in the section.

11.3.4 In case of conflict between the above standards and the specifications given herein, the specifications shall take precedence.

11.4 General

11.4.1 Shotcrete shall be applied by either the wet process to the circumstances. All aspects of the application of shotcrete shall be subject to the agreement of the Engineer. Particular emphasis shall be placed on the provision of adequate ventilation.

11.4.2 The Contractor shall develop a shotcrete mix and a plan for its production and application. Specifications of constituent materials shall comply with those listed in this. Admixtures shall be compatible with each other and the mix.

11.4.3 The shotcrete mix design shall, unless otherwise stated, comply with the characteristic strengths specified by the Designer for early-age and long-term loading.

11.4.4 Contractor's shotcrete expert should be on site at all times to check that the materials and workmanship are consistent with the design intent, and to ensure that ground and

groundwater conditions are in accordance with design assumptions. The Contractor shall establish a procedure to respond effectively to changes in ground and groundwater conditions from the design assumptions.

- 11.4.5** The Contractor shall establish and maintain the instrumentation and monitoring required by the design. The Contractor shall establish a procedure that will enable prompt and regular review and effective response to the results from the instrumentation and monitoring. The Engineer shall be included in the monitoring review procedure.

11.5 DEFINITIONS

- 11.5.1** Shotcrete: Shotcrete for the purpose of this work is defined as wet mix of cement concrete (plain) or fiber reinforced (SFR) applied from a spray nozzle by mean of compressed air. The Engineer may, in exceptional cases, allow use of dry mix for plain shotcrete. Shotcrete shall contain approved additives like Accelerator, Superplasticizer, retarder, stabilizer, Pumpability improving additive or curing agents suitable to attain desired properties as mentioned in these specifications and site conditions.

- 11.5.2** Rebound: Rebound is defined as the portion of shotcrete mix or any of its constituents, which bounces away from a surface against which it is being projected.

11.6 MATERIAL FOR SHOTCRETE

- 11.6.1** Material for shotcrete shall comprise cement, aggregates, fiber, water and approved admixtures, micro-silica/silica fume as specified herein.

11.6.2 Cement:

- i. Cement used shall be ordinary Portland cement of 53/53S grade.
- ii. ***For M30 Grade Shotcrete: Minimum OPC 53/53S content will not be less than 385 Kg/cum. Minimum 15 Kg/cum Micro-silica/silica fume will be added to enhance mix durability and reduce life cycle cost of shotcrete.***
- iii. Preferably cement fineness shall not be less than 275 m²/kg for OPC 53 and 370 m²/kg for OPC 53S.
- iv. Maximum temperature of the cement in the mixing plant silos should be limited to 70°C and it should not exceed 50°C at the time of mixing. Cement should be preferably purchased in bulk and fresh cement shall be stored in a suitable silo.

11.6.3 Aggregates:

- i. All fine and coarse aggregates to be used shall be supplied from approved sources, which shall not be changed without permission in writing from the ENGINEER Aggregates shall conform to the requirements of IS:383.
- ii. The aggregate shall be checked for chemical reactions, such as alkali–aggregate reaction, with latent hydraulic binders and admixtures, especially accelerators.
- iii. The aggregates size for shotcrete **shall not exceed 10 mm**. The proportion of aggregate larger than 8mm in size should not exceed 10%. The aggregate shall be well graded, and no fraction shall constitute more than 25 % of the total. The

contents of the crushed and non-cubical material under 0.1mm shall not exceed 8 %.

- iv. Acceptance of source by Engineer shall not be construed as constituting the acceptance of all aggregates to be taken from that source or grading of aggregates to be in conformance with contract.
- v. It is the responsibility of the Contractor to choose the most suitable grading for the process and materials available from the range given in table below. The grain size distribution of aggregates shall be within $\pm 2\%$ for each sieve size as shown below:

Standard Sieve	Sieve Size [mm]	Passing in %
IS	10.0	100
IS	8.0	90-100
IS	4.0	73-100
IS	2.0	55-90
IS	1.0	37-72
IS	0.50	22-50
IS	0.25	11-26
IS	0.125	4-12

11.6.4 Fibers: Macro Synthetic fibers shall be used which shall conform to specifications mentioned below.

- i. The macro-synthetic fibers shall be in accordance with BS EN 14889-2. Fibers shall be dry and free from oil, grease and chlorides and shall be provided with arrangements to deliver anchorage properties. The fibers shall satisfy the following parameters:

Class	Class-II (EN 14889-2)
Length of fibers	45-55 mm.
Type of handling	Mulchable paper bags.
Geometric shape	Regular cross section (More than 0.30mm of equivalent Diameter) fully embossed.

Class	Class-II (EN 14889-2)
Tolerances and sampling	In accordance with EN 14889-2.
Aspect Ratio (Length / Diameter)	≥ 64
Tensile strength	≥ 550 MPa, when tested in accordance with EN 10002-1.
Modulus of Elasticity	≥ 5 GPa.
Quantity of fibers	Maximum 5 Kg/ M ³ (E700) Maximum 7 Kg/M ³ (E1000) (Subject to mix design/field trials)

- ii. Mixing procedure adopted by the Contractor should be such that there is no fiber balling.
- iii. Storage: Fibers shall be stored, handled and dosed in accordance with the manufacturer's recommendations. Generally, this will require them to be stored in dry, sealed containers until ready for use and shall be free from oil, grease, chlorides and deleterious materials which may reduce the efficiency of mixing or spraying processes, or which may reduce bond between the fibers and the shotcrete.

11.6.5 Air used for spraying shotcrete shall be clean and free of oil.

11.6.6 Water used for mixing shall comply with IS-456. Water to cement ratio shall be less than 0.43.

11.6.7 Admixtures: Admixtures conforming to IS:9103 shall be used to develop quick set and high early strength, to ensure good workability, low pumping pressure, adequate slump retention and low rebound as approved by the Engineer, conforming to the requirements of the relevant standards. The proportion of admixtures shall be kept less than 10-12% of the weight of cement or as determined by testing prior to any shotcrete work.

i. General

- a. Technical criteria, approved documentation, test reports and test certificates shall be furnished to the ENGINEER for approval.
- b. Admixtures shall be stored under the conditions specified and recommended by the manufacturers. The related storage Specifications and recommendations shall be presented to the ENGINEER before approval of such admixtures.

- c. The manufacturer's safety instructions shall be observed. Admixtures shall be free of chlorides such that the percentage of chlorides shall not exceed 0.1% by weight.
 - d. The required characteristic values and consistency of delivery to the site shall be agreed in writing with the manufacturer of each admixture before commencement of concrete spraying.
 - e. Written confirmation of the stability of admixtures with the mix water shall be provided prior to commencement of site trials.
 - f. The content of SO₃ shall not exceed 4.8% by weight of total binder content.
- ii. Accelerators
- a. Accelerators are used to produce a fast set and to get sufficient early strength development. Accelerating admixtures shall be compatible with the cement used. The compatibility shall be tested in the laboratory by the Manufacturer and verified by the Contractor in field suitability tests to achieve the required properties for early and final strength.
 - b. The accelerator must mix with the concrete in the nozzle and begin the hardening immediately after the concrete hits the rock.
 - c. Only liquid alkali-free accelerators (pH 2.0 to 8.0 and having alkali content less than 1% by weight Na₂O equivalent) shall be used. Additives based on Lingo sulphates (P agents) shall not be used due to retarding and reduced early strength.
 - d. The accelerators shall be added at the nozzle and only the minimum quantity of accelerator necessary shall be permitted in normal concrete spraying operations. The quantity shall be determined by site trials, subject to maximum dosage of 7% by weight of cementitious materials. Higher dosages of upto 8% accelerator can be considered subject to establishing the effect of the dosage rate on the medium and long-term strength development on the in-situ concrete. At no stage in the strength development should the strength of the accelerated mix drop below 0.7 times the strength of the unaccelerated concrete mix.
 - e. Testing of accelerators and the base mix with respect to acceleration of setting, early strength and decrease of strength at a later age (28 days), shall take place in due time before commencement of concrete spraying.
 - f. Laboratory testing of the selected type(s) of accelerator shall be carried out at dosages as recommended by the manufacturer, to establish the variability of the above properties with dosage. Accelerators showing excessive variability with dosage will not be permitted.
 - g. Accelerators shall be selected so that, at the dosage chosen for use in the Works, the characteristic compressive strength of any shotcrete at an age

of 28 days can be achieved. Compliance with this clause shall be demonstrated by site trials.

- h. Accelerators delivered to site shall be tested at least once every two months for their reaction with the Portland cement used, with particular reference to the setting behavior and strength decrease after 28 days. The stability of accelerators during storage shall be visually inspected at similar intervals. Storage times and working temperature ranges shall be in accordance with the manufacturer's recommendations. The manufacturer's safety instructions shall be observed.

iii. Super Plasticizers and retarders

- a. Used to reduce the quantity of the mixing water and to improve the pumpability of the concrete. The effects and optimum dosages shall be determined by site trials.
- b. The above-mentioned desired properties shall only be attained through superplasticizers.
- c. Shall be added at the batching plant to keep the shotcrete mix workable during transportation and to ensure good pumpability to an acceptable low water cement ratio.
- d. The influence of the superplasticizers and retarders within the concrete mix shall be checked regularly for setting time, water reduction, and development of strength. These values shall be compared with the results from the pre-commencement trials.
- e. Compatibility of superplasticizers and retarders with Portland cements, latent hydraulic binders and accelerators shall be verified by observation and site trials. Traditional retarders shall not be allowed.

iv. Hydration control admixtures

- a. Hydration control admixtures may be used to control the hydration of the mix as appropriate to expedite construction of the Works. The effects and optimum dosages of hydration control admixtures shall be determined by site trials.
- b. Compatibility of hydration control admixtures with Portland cements, latent hydraulic binders and accelerators shall be verified by observation and site trials. Hydration control admixtures shall be used in accordance with the manufacturer's instructions.

11.6.8 Additives: Micro-silica or silica fume

- i. Micro-Silica or Silica fume shall conform to ASTM C1240 / IS-15388. Contractor shall submit MTC from original manufacturer. Manufacturer shall furnish evidence of factory production control systems.

- ii. The performance of the shotcrete mix with optimum dosage of additives shall be determined by field suitability tests. Testing of Silica fume shall be carried out by contractor before or anytime during its usage at discretion of engineer.
- iii. Micro Silica/ Silica fumes shall have a bulk density between 600-700 kg/m³. Micro Silica/ Silica fumes shall be added in the mix at the batching plant facilitating the mixing and distribution of fibers to reduce fiber rebound and improve bond between cement matrix and fibers. Dosage of Micro Silica/ Silica fumes shall be as per Mix design subject to minimum 15 Kg per cum of shotcrete mix.

11.6.9 Curing agents

- i. External curing agents and internal curing admixtures shall be allowed to maximize hydration of the cement by reducing uncontrolled water evaporation.
- ii. The curing agent selected should not affect the bond of further layers/coatings or be easy to remove. Solvent based curing agents should be avoided
- iii. External curing agents are sprayed onto the surface of the shotcrete shortly after it has been applied. When set accelerators are used, an external curing agent should be applied within 15 minutes after the end of spraying. When no accelerators are used it should be applied within 30 minutes.
- iv. Internal curing admixtures are special admixtures added to the mix (see 4.6). Compatibility of curing agents with cements, hydraulic binders, accelerators and other admixtures should be verified in site trials. Particular care must be taken to ensure adequate mixing when used in the dry-mix process.

11.7 MIX DESIGN AND PROPORTIONING

11.7.1 The type of shotcrete to be used in a particular location shall be as per drawings and as directed by the Engineer.

11.7.2 The mix proportions of cement, aggregates, and permitted admixtures in each class shall be determined by the Contractor satisfying the requirements given in Table no. 1 below and shall be subject to the approval of the Engineer. The mixes shall be such as to permit placement without excessive rebound and segregation.

Table-1

28-day Characteristic compressive strength of Cylindrical cores (after applying a factor of 0.85 for In- Situ coring effects)	Aggregate size/grading	Cementations content, (C) kg/M ³	Water cement ratio
--	------------------------	---	--------------------------

30 MPa (Average of 4 consecutive non-overlapping tests)	Size grading: $D_{max} \leq 10$ mm, Aggregate flattening coefficient ≤ 20 .	Refer para 11.6.2	≤ 0.43
---	--	-------------------	-------------

- 11.7.3** The water content of the mixes shall be limited to prevent sloughing. The water: cement ratio of fresh shotcrete in place shall be less than 0.43.
- 11.7.4** Slump of mix shall be kept less than 200mm, as high value of slump will affect fiber distribution in the shotcrete.
- 11.7.5** The Mixes shall be such that aggregate gradation and cement content after placing are as those obtained from samples taken from test panels produced from approved trial mixes. All constituents shall be uniformly dispersed throughout the mix.
- 11.7.6** Proportioning of aggregates and cement shall be only by weigh batching.
- 11.7.7** Moisture content of the combined aggregate at the time of mixing with cement shall not exceed 6 % (Six percent) by weight of the over dry aggregate.
- 11.7.8** Mixed material shall be used within 90 minutes after addition of water to cement. This period may be extended by the use of hydration control admixtures, subject to the approval of engineer.
- 11.7.9** The addition of fibers shall be at a stage in the mixing suitable for the sprayed concreting equipment. Fibers shall be added and mixed in a manner to avoid clumping and bending of fibers. Any fiber clumps in the mix shall be diverted and removed by means of a screen placed over the shotcrete hopper. Fibers shall be uniformly distributed throughout the mortar matrix without isolated concentrations.
- 11.7.10** Approved mix proportions may have to be varied, during execution stage, to obtain required strength of shotcrete, to maintain rebound to the minimum and to meet other requirements of Contract. The Contractor shall notify to the Engineer of all variations to the mixes.
- 11.7.11** The Contractor shall carry out all field tests before hand and then propose mix design for shotcrete to meet the requirements of the specifications for prior approval of the Engineer. The quantities of super plasticizers may be adjusted to compensate the slump loss because of fiber. The mix design shall provide the following details for one cubic meter of Shotcrete.
- a. Ordinary Portland Cement Kg
 - b. Microsilica Kg
 - c. W/C Ratio
 - d. Aggregate
 - i. Natural fine aggregate Size Kg
 - ii. Natural coarse aggregate Size Kg
 - iii. Crushed fine aggregate Size Kg

iv.	Crushed coarse aggregate Size	Kg
e.	Super Plasticizer Agent	Kg
f.	Retarder or Stabiiser	Kg
g.	Internal curing	Kg
h.	Pumpability iimprover	Kg
i.	Alkali free Accelerator	Kg
j.	Fibre (Aspec Ratio/Length)	Kg
k.	Slump	mm
l.	Density (Wet)	Kg/cum

11.8 Equipment

- 11.8.1** Details of all equipment to be used shall be made available to the Engineer prior to commencement of site trials.
- 11.8.2** The equipment selected and approved by the Engineer will be capable of maintaining the ratio of concrete and accelerator as selected from the trials and approved by the Engineer. The actual ratio of accelerator to concrete selected shall be identified at the nozzle and take into account the filling efficiency of the equipment and the efficiency of the accelerator dosage equipment to overcome the air and concrete pressure at the nozzle while spraying at typical outputs and air flows. ***Contractor shall provide shotcrete machine data in digital format after every cycle whenever required by Engineer.***
- 11.8.3** Equipment shall be thoroughly cleaned at least once per shift. The spray nozzle shall be checked for wear and where necessary replaced.
- 11.8.4** Transport pipes consisting of hoses and pipes shall be designed to convey the concrete efficiently and without leakage or blockage. The transport pipes shall have uniform diameter appropriate to the mix characteristics determined by site trials and be free of any dents or kinks between the shotcrete machine and the nozzle.
- 11.8.5** Working area for sprayed concreting shall be well illuminated and ventilated. Dust pollution shall be minimized by choice of appropriate equipment and by means of additional ventilation, water sprays, and by maintaining equipment in good order. Protective clothing and dust masks shall be provided for and used by all persons present during spraying.
- 11.8.6** The equipment shall allow for air and water in any combination to be available for preparation of surfaces and/or cleaning of finished work.
- 11.8.7** **Recipe of mix shall be entered into PLC control prior to spraying.**
- 11.8.8** A boom mounting or similar device shall be provided for the spray nozzle unless it can be demonstrated to the Engineer that the use of such equipment is impractical.

- 11.8.9** In particular, the spray nozzle shall be kept as perpendicular as possible to the surface and care shall be taken to achieve a regular properly compacted coating of the correct thickness.
- 11.8.10** The shotcrete shall emerge from the nozzle in a steady uninterrupted flow. Should the flow become intermittent for any cause, the nozzleman shall direct it away from the work until it again becomes constant.
- 11.8.11** The thickness and position of the shotcrete shall be defined by screed boards, lattice arches, guide wires, depth pins, lasers or other means.
- 11.8.12** The site trials shall employ the equipment which will be used in the Works and the constituent materials shall be fully representative of those to be used in the Works. A clean, dry mixer shall be used, and the first batch discarded.
- 11.8.13** The equipment proposed for the application of concrete in the Works shall be used for the trial. The trial will establish whether the selected equipment is capable of efficiently mixing concrete, accelerator and air at the nozzle, and be capable of positioning the nozzle at a suitable distance and orientation to the surface geometry of the structure to which the concrete is to be applied.
- 11.8.14** During the trials the Contractor will establish the volume of air required to give adequate compaction of the material using the nozzle and conveyance lines selected for the Works. If the delivery equipment or nozzles are to be changed during the course of the works, the volume of air required will need to be verified again. The equipment will be maintained adequately, to ensure that the required volume of air can be maintained while spraying. Air pressure can only be used as a control if the air delivery system is not altered from the original verification trial. No additional taps or restrictions will be permitted to be added into the system without repeating the verification trials.
- 11.8.15** The static compressed air capacity measured at the shotcrete pump shall be according to the manufacturer's recommendations and generally as per EFNARC guidelines G 8.3.2 for wet process and G 8.3.3 for dry process.

11.9 **QUALITY CONTROL AND TESTING**

- 11.9.1** The Contractor shall enable the Engineer access to the shotcrete Works at all times and shall allow the Engineer access to inspect the excavated ground surface prior to spraying if requested.
- 11.9.2** The quality control and testing of shotcrete (Plain and SFR) shall be carried out by the Contractor in the presence of Engineer. Tests for Field suitability (to determine mix design) and In-situ suitability (to control quality) shall be carried out separately. Field suitability tests shall be carried out on minimum three test panels for initial establishment of suitable range of accelerator/superplasticizer dosage (All types of Shotcrete), and fibre content of hardened concrete and Energy absorption class (SFR) for the required strength of shotcrete mix. The pressure at which the shotcrete shall be applied to the test panels shall be the same as will be used in actual works at the place of application. Mechanical rebound hammers shall not be used to obtain indirect compressive strength of shotcrete.

- i. Control of Fresh shotcrete:
 - a. Water/Cement ratio: Daily by calculation or test method.
 - b. Aggregate gradation: Weekly by standard sieving.
 - c. Accelerator/Superplasticizer: Daily through record of quantity added.
 - d. Slump: For Each batch separately, measured any time during application, at the pump and should conform within 25mm of the target slump range established earlier and approved by engineer.
 - e. Fibre content: For fresh shotcrete, one test every 100cum or 500m² (Whichever achieved first) of shotcrete applied in accordance with EN 14488-7. For hardened shotcrete, testing shall be done when testing energy absorption capacity.
 - f. Early (0-24hrs) strength development: Strength results shall conform to Class J2 as per EN-144887-1 unless specified otherwise in the design drawings. In-situ test shall be carried out every 250m² of shotcrete applied subject to minimum 2 test per month in accordance with EN 14488-2 (Strength up to 1.0 N/mm² shall be determined by Penetrometer and in the range between 1.0 and 16 N/mm² shall be determined using the HILTI shot bolt method).
- ii. Control of hardened shotcrete:
 - a. In-situ strength shall be carried out on shotcrete applied at the tunnel face and shall be determined by crushing of cylindrical shotcrete specimens. Samples shall be collected with core drilling equipment from In-situ shotcrete applied on tunnel wall/or from test panels as the case may be, after lapse of 1 day. Cores for strength testing shall be obtained from random locations. The cores will be visually inspected and the dimensions and comments regarding the quality of the cores will be recorded. The cores will be free from lamination. No sets of cores to be tested at any given age shall come from the same panel/In-situ location. Sets of cores to be tested at different age may come from the same panel/In-situ location. For each test at least one spare specimen shall be provided. The cores for determination of strength shall be cured in temperature-controlled water until 3 days before further testing. The specimens shall have a diameter of 100mm and be cut to a height of 100mm. Where the nominal required shotcrete thickness is less than 100 mm, the cores for the compressive strength testing shall be taken from areas where the actual thickness is greater than 100 mm. Alternatively additional shotcrete thickness shall be applied in selected areas agreed by the Engineer for subsequent coring of test specimens.
 - b. Further (1-7days) Strength Development: Average strength of 3 cores tested at 3 days and 7 days each shall exceed 12.5MPa and 70% of 28-day strength requirements respectively. The ENGINEER may also require the

drilling of cores from the test panels perpendicular to the spraying direction.

- c. Final strength: 3 cores shall be further tested at 28th day and at completion of 6 month each and the 28-day strength obtained shall exceed 28-day strength requirements mentioned in Table-1 at 11.7.2. Strength results at 6 months shall not be less than 28-day results.
- d. Energy absorption class for Fibre Reinforced Shotcrete: Field suitability tests shall be conducted to ascertain the fiber content required for different energy absorption classes. One test every 100cum or 500m2 (Whichever achieved first) of shotcrete applied in accordance with EN 14488-5. Two classes are required to be designed i.e. E700 and E1000. The design shall be considered satisfactory when each test result exceeds the required energy absorption value by a margin of 5% or more. Fibre content of hardened concrete shall also be measured in accordance with EN 14488-7. These tests shall be performed on site in contractor's field laboratory setup for this purpose. No extra cost on account of testing shall be payable to the Contractor.

iii. Shotcrete thickness: In addition to recording tunnel wall profile before and after shotcrete by tunnel profiler etc., the Contractor will be required to undertake confirmatory shotcrete thickness testing of the in-situ tunnel lining. The basic test shall consist of 4 nos. drill holes drilled on a 1m² pattern. The average thickness of the 4 holes shall exceed the specified design thickness. If not, the ENGINEER shall propose remedial measures and/or further drill testing. All such drill holes shall be subsequently filled back by Non shrink mortar. Nothing extra shall be paid on this account.

iv. Bond Strength

Bond strength of shotcrete shall be tested every 1250m² (in case of Ground strengthening) or min 3 tests (in other cases) of the shotcrete applied in accordance to EN 14488-4. Bond strength between plain shotcrete and fiber reinforced shotcrete shall also be established.

v. Contractor shall keep at site various testing tools like Penetrometer, HILTI shot bolt, Shotcrete core cutter, Test panels etc. along with all spares required as per standards and specification mentioned above. The frequency of testing, test type or the testing method will not be altered without approval of Engineer. Shotcrete from both the field suitability test panels and the In-situ quality control shall be tested by the Contractor in the presence of Engineer. Engineer may ask contractor to undertake further tests for examination purposes.

11.9.3 Dimension, tolerances and sampling of fibers shall be in accordance with EN 14889-2. Criterion for Tensile strength, Ductility and Modulus of Elasticity have been specified earlier. Furnishing evidence of manufacturer's factory production control system meeting requirements of EN 14889-2 and EN ISO 9000 shall be mandatory and sufficient for QC of fiber, however the Contractor shall be ready to demonstrate the

same by carrying out initial type tests (EN 14889-2) in approved laboratories as required by engineer before or anytime during usage. No payments for conducting these tests shall be made by the employer.

- 11.9.4** The Contractor shall propose to and agree with the Engineer trial mixes for the works at least 56 days before their commencement. Tunneling shall not be permitted to start until the Field suitability tests have been approved by the Engineer.
- 11.9.5** The site trials shall be repeated if the source or quality of any of the materials, mix proportions or placing equipment is to be changed during the course of the Works.
- 11.9.6** Where shotcrete does not comply with the required strength, the Contractor shall execute remedial work which may involve additional shotcrete or replacement in sections where it is safe to do so. The Contractor shall take into account any limits placed on the tunnel profile dimensions resulting from the Specification. The Contractor shall submit to the Engineer for agreement, a method statement, specification and calculations for remedial work. The Engineer shall, in the event of repeated failure in Quality Control, require the Contractor to adjust the mix to achieve the required strength.
- 11.9.7** The Contractor shall keep a record in a form to be agreed with the Engineer of all tests on shotcrete, which shall be kept on site identifying the tests with the section of work to which they relate.

11.10 ROBOTIC SHOTCRETE MACHINE

- 11.10.1** Shotcrete shall be carried out by Robotic shotcrete machine.

11.11 PLACING OF SHOTCRETE

- 11.11.1** Rock or previously applied shotcrete surfaces to be shotcrete shall be carefully cleaned of all loose material, scale and other contaminations. It may be necessary to use compressed air and a water jet. The surface to receive shotcrete shall be damp but shall not exhibit free water.
- 11.11.2** Where groundwater flow could interfere with the application of shotcrete or cause reduction in the quality of shotcrete the Contractor shall take all action necessary to control groundwater. Such action shall include the channeling of water by means of pipes and chases.
- 11.11.3** The optimum distance between nozzle and surface of application is 1.5 to 2.0 meter. The nozzle shall be positioned at right angles to the surface of application.
- 11.11.4** For vertical and near-vertical surfaces application shall commence at the bottom and the leading edge of the work shall be maintained at a slope. Downward spraying shall be avoided where possible. The nozzle may be inclined sufficiently to ensure reinforcement is properly embedded.
- 11.11.5** If the design thickness must be applied in more than one layer, then the previous layer must have developed sufficient strength to support the additional layer(s). Lattice girders, roof ties, wire mesh and other reinforcement shall be embedded in shotcrete as

shown on the drawings. The minimum cover of wire mesh and re-bars applied at the inner side of a tunnel lining shall be 2 cm or as shown on the drawings.

- 11.11.6** Prior to continuation of spraying from a joint or leading-edge position or in any other circumstances where shotcrete has hardened beyond its initial set, loose material shall be removed by jetting with a compressed air lance. Any laitance which has been allowed to take final set shall be removed and cleaned by jetting with air and water.
- 11.11.7** If more than one layer of reinforcement is used, the second layer shall not be positioned before the first one is embedded and covered with shotcrete. Exemptions are to be approved by the ENGINEER.
- 11.11.8** The temperature of the mix before placing shall not be below 15⁰C and shall not exceed 35⁰C unless special provisions are made. Spraying shall not be undertaken when ambient temperature is below 15⁰C unless special measures can be taken to provide protection against frost until the shotcrete has developed a compressive strength of at least 5 MPa.
- 11.11.9** A system of delivery notes shall be maintained to record the date, the time of mixing, mix design number, quantity, delivery point, time of delivery and completion of placing. The delivery notes shall be available to the ENGINEER for inspection.
- 11.11.10** Rebound shall be removed immediately after finishing of each shotcrete application. In particular at horizontal shotcrete connections due to separate excavation sequences and at all construction joints the rebound shall be removed, if necessary, by pneumatic hammers, prior to further application of shotcrete.
- 11.11.11** Under no circumstances rebound material shall be worked back into the construction. The work shall be continuously kept free of rebound material.
- 11.11.12** Measures to establish the thickness of shotcrete shall be set up by the Contractor and approved by the ENGINEER. These may include visual guides installed prior to shotcrete, holes drilled after completion of shotcrete or a full control by laser scanning.
- 11.11.13** Shotcrete shall be left in its natural finish without further working except as required to trim excess thickness where the shotcrete shall be allowed to stiffen sufficiently before being trimmed with an approved cutting screed.
- 11.11.14** If deemed necessary by the ENGINEER, curing of the shotcrete shall be performed by water spraying or other appropriate measures subject to the approval of the ENGINEER in the first 48 hours after application.
- 11.11.15** Major ground water seepages shall be drained off or sealed off by grouting prior to spraying or after application of a first sealing layer.
- 11.11.16** Construction joints or stop joints shall be provided, as directed by the Engineer and shall be sloped at 45⁰ to the adjacent shotcrete surface in a clean, regular edge. Before placing the adjoining work, the sloped portion and adjacent shotcrete shall be prepared as specified in clauses above.
- 11.11.17** Before a succeeding layer of shotcrete is placed, the preceding layer shall be checked for defects. Areas of work shall be properly compacted and bonded and free from

honeycombing, laminations, dry or sandy patches, voids, sagged or slumped material, rebound, excessive cracking and overspray.

- 11.11.18** Where defects occur, the Contractor shall agree with the Engineer proposals for the removal of the defective material and replacement by material without defect and the area to be replaced shall in any event be not less than 300mmx300mm at such locations.
- 11.11.19** Gloves and necessary protective clothing shall be worn to protect against dermatitis.

CHAPTER -12

DRILLING AND GROUTING

12.1 SCOPE OF WORK

12.1.1 The specifications described herein under relate to the Work of drilling and grouting, which includes all labour, materials, equipment, accessories and operations and required for the performance of drilling grout holes, holes for rock bolts/anchors and instrumentation, washing and water pressure testing of grout holes and supplying, transporting, storing, mixing and injecting grout materials and additives for consolidation and curtain grouting including void filling/contact grouting within the underground constriction sites and from surface, at locations shown on the drawings or where directed by the Engineer.

12.1.2 Grouting operations shall include the following:

- i. Contact grouting: To fill voids between final concrete lining and primary support system applied to rock surface.
- ii. Consolidation grouting, of the rock surrounding the excavated hollow space, which shall commence after placing of the concrete lining/shotcrete and completion of contact Grouting.
- iii. Consolidation grouting in the heading zone during excavation to consolidate the heading face before further advance in zones of sheared and disturbed material and/or in zones of high-water inflow.
- iv. Fill grouting, of karstic cavities, drainage trench, conduits and sump pits, and of exploratory drill holes and drain holes.
- v. Crack grouting, to seal open cracks and joints in the structural concrete lining.
- vi. Chemical grouting in zones of fine sand and soils, and to control the water inflow and increase the stability and strength of the formations that are too tight to be grouted with a cement grout.
- vii. Compensation grouting: Pre-injection of grouting at a controlled pressure prior to tunneling permeate the area to avoid deformations due to tunneling activities

12.1.3 The final number, length, location and inclination of the drill holes, as well as the composition and consistency of the grout mixes, grouting pressures pumping rates and sequence in which the holes are to be drilled and grouted shall be governed by actual conditions encountered on site and shall be at all times subject to approval by the Engineer.

12.1.4 Contractor shall follow the grouting strategy as approved by Engineer.

12.1.5 Contractor shall maintain one-month buffer stock of grout materials as per agreed programme or as directed by Engineer.

12.2 SUBMITTALS

12.2.1 At least 14 days prior to the start of grouting works, The Contractor shall provide a grouting method statement for the Engineer's agreement. The proposals shall include

details and location of the mixing plant and grout pump, mix design and constituents, pumping rates and pressures, injection points, methods of monitoring, recording and controlling the sequence, preventing grout leakage and reconciling the volume of grout placed with the theoretical volume required, including specifications of all equipment, tools and all grouting materials to be used, and qualification and experience of the proposed personnel.

- 12.2.2** Grouting shall be carried out by operatives skilled in the work and notified in advance to the Engineer. They shall produce evidence of satisfactory performance on projects where the purpose of the work and extent was comparable. The skilled operatives shall further undergo training from OEM whose equipment is being proposed to be used at site.
- 12.2.3** An overall drilling and grouting Program shall be drawn up jointly between the Contractor and the Engineer. Grouting mixes, pressures, pumping rates, and sequencing will be selected, subject to modifications, to meet local conditions encountered during the performance of the work. Grouting works shall be planned in such a manner that they can be carried out according to the approved plan concurrently with other activities.
- 12.2.4** The Contractor shall decide and consult with the Engineer details of the proposed grouting scheme including:
- i. Information and case records to support the grouting proposed in respect of its ability to penetrate the strata and its ground enhancement effect.
 - ii. Specific criteria to measure the adequacy, sufficiency or completeness of the ground treatment.
 - iii. Details of the treatment zone and grout injection patterns with respect to the Works and adjacent structures.
 - iv. Details of plant proposed.
 - v. Method statement and programme including arrangements for storage of materials, mixing grout, Quality Control of grout, recording grouting pressures and grout take and tests to prove the efficacy of the grout in the ground, health aspects associated with the materials and grout proposed at all stages of the process and during excavation of treated ground, and means of protecting persons from any adverse effects
 - vi. An assessment of the environmental impact of the materials and methods proposed.
 - vii. An occupational health risk assessment, including methods of risk reduction on all aspects of the grouting operation.
- 12.2.5** Contractor shall record grouting pressures and flows and produce ongoing assessments of the grout performance in relation to the requirements of grouting objectives.
- 12.2.6** During the performance of the grouting works the Contractor shall keep complete daily records of all grouting operation which shall include the following:
- i. Number and location of the drill holes.

- ii. Results of water pressure tests.
- iii. Grouting method.
- iv. Date and time of commencement and of each change in grouting operations.
- v. Rate of pumping.
- vi. Grouting pressures and gauge reference number.
- vii. Water-cement ratio and its variations.
- viii. Quantities of cement, sand, bentonite, fly ash, admixtures and chemicals used.
- ix. Connections, if any, with other holes and cracks, as well as any surface leakage of water or grout. Location, how caulked and the success of caulking shall be described.
- x. Number of holes and depth of holes left for re-drilling.
- xi. Time of completion.
- xii. Name of the Foreman in-charge.

12.2.7 Grouting reports in an approved form shall be compiled from these records and submitted to the Engineer for approval. Results of water pressure tests and grout intakes shall be presented graphically. The above reports shall also cover the interpretation of the test results and the actions proposed to be taken by the Contractor for improving the quality of grouting pattern.

12.2.8 The Engineer reserves the right to require any additional information deemed necessary to be included in the submitted documents.

12.3 STANDARDS

12.3.1 Materials for grouting and performance of grouting works shall conform to the following Indian Standards or where not covered by these standards, to the equivalent International Standards:

- i. IS: 12269 Specification for 53 grade ordinary Portland cement.
- ii. IS: 383 Specification for coarse and fine Aggregates from natural source for concrete.
- iii. IS: 5529(Part-II) Code of practice for in-situ permeability tests.
- iv. IS: 5878 (Part-VII) Code of practice for construction of tunnels conveying water: Grouting
- v. IS: 9103 Concrete Admixtures: Specification
- vi. IS: 6066 Recommendations for pressure grouting of rock foundations in river valley projects.
- vii. IS:10874 Portland Micro-Fine Cement Specification
- viii. IS:14343 Choice of grouting materials for alluvial grouting

12.3.2 In cases of conflict between the above standards and the specifications given herein, the Specifications shall take precedence.

12.4 DEFINITIONS

12.4.1 Cement grout

- i. Cement grout is defined as a mixture of cement and water with the addition of admixtures (sand and bentonite, if directed by engineer), which is forced under pressure into prepared holes or pipes in order to fill voids or consolidate the rock mass as a whole.
- ii. Cement grouts are subdivided into stable and unstable mixtures:
 - a. Unstable mixtures are simple suspensions of cement in water. These suspensions are homogeneous as long as they are in movement and the sedimentations starts as soon as the movement is stopped.
 - b. Stable mixtures are colloidal suspension dissolved in water of which grain size is so small that no appreciable sedimentation occurs during the grouting operation. These suspensions are obtained by high speed mixing of cement with addition of bentonite.

12.4.2 Chemical Grout is defined as mixture of two or more solutions which combine chemically and form a gel or a solid matter, the solutions may react either prior to pumping into, or within the void. The chemicals may be used in combination with cement or other grout as determined by testing and approved by the Engineer.

12.4.3 Single-Stage Grouting is carried out by introducing the grout at either the collar of the hole through a nipple or by means of a grout supply pipe at the bottom of the hole. The entire length of the hole is grouted in one operation.

12.4.4 Multiple Stage Grouting

- i. Multiple stage grouting is carried out by introducing the grout into a predetermined section of the hole, which is blocked off by a packer. The grouting of the entire length of hole is performed in successive stages either in ascending or descending arrangement.
- ii. The terms ascending or descending arrangement mean the sequence of the grouting stages, either from bottom to the collar of the hole or in reverse, irrespective of the effective direction of inclination of the hole.
- iii. When grouting is done in ascending arrangement, the hole is drilled to its full depth, washed out, and the packer is set at the top of the deepest section to be grouted at the required pressure through the grout supply pipe. The packer is allowed to remain in place until there is no backpressure and then withdrawn to the top of the next section to be grouted. The water pressure testing and grouting is repeated successively, section by section, until the entire length of the hole is filled with grout.
- iv. When grouting is done in descending arrangement, the work is accomplished in section from the collar of the hole. The hole is drilled to a limited depth,

washed out and the packer is set just above the section to be grouted. The section is then water-pressure tested and grouted at the required pressure. The grout within the hole is removed before it takes a hard set while the grout surrounding the hole is allowed to obtain its initial set, before the holes is drilled to an additional depth. Repeating thus successively drilling, water-pressure testing, and grouting at various depths until the entire length of hole is completely drilled and grouted.

12.4.5 Split spacing Grouting means the system of locating an additional grout hole approximately mid-way between two previously drilled and grouted holes.

12.4.6 Water Cement Ratio is the proportion by weight of water to cement in a water-cement mixture.

12.5 GENERAL

12.5.1 During drilling, grouting, washing and pressure testing operations, the Contractor shall keep concrete and rock surfaces free and clean of oil, grease, drill cuttings, grout, cement, excess of water or any kind of waste. At all times during the progress of Work pertaining to this item, contractor shall protect all open drill holes from becoming plugged or filled with oil, grease, drill cuttings, grout or waste. The Contractor shall clean up and remove all waste in each area on completion of the work.

12.5.2 Before starting the grouting, the Contractor shall give due notice thereof to the Engineer, to enable him to be present during the grouting operations, which shall always be done in his presence.

12.5.3 The grout mix that might flow out or otherwise get spilled on the concrete lined surface shall be removed expeditiously without allowing any time for the grout to set on the concrete surface.

12.5.4 After finishing of grouting, each grout hole shall be re-drilled to $\frac{2}{3}$ rd of theoretical lining thickness and fitted with dry pack mortar.

12.6 SAMPLING AND TESTING

12.6.1 The Contractor shall provide samples of materials and prepare trial mixes as directed by the Engineer and test in the presence of Engineer at least 30 days before the commencement of any grouting. The materials for use in grout mixes shall be tested with applicable requirements stipulated in these specifications.

12.6.2 The Contractor shall carry out the following tests:

i. Laboratory Tests

- a. Grain size distribution and moisture content of sand and bentonite, including aerometer analysis.
- b. Atterberg limits.
- c. Chemical analysis of water and solids.
- d. Compressive strength.
- e. Viscosity (by fan-viscosimeter and Marsh cone).

- f. Density.
- g. Decantation and setting time (by Vicat needle).
- h. Shrinkage of grout.

ii. Field Tests.

- a. Density by hydrometer or mud balance.
- b. Viscosity by marsh cone.

12.6.3 All Chemical grouts shall be tested in NABL approved laboratory under conditions identical to those to which they will be subjected in the field, in order to determine the suitability of various chemicals and proportion of the ingredients to satisfactorily complete the work.

12.6.4 During the actual grouting operations, contractor in the presence of the Engineer will carry out tests on grout mixes at the same time as grouting, and will plot values of viscosity, sedimentation limits, compressive strength, and maximum viscosity possible for the grouting on a diagram. The frequency of testing will be once for each grouting jobsite or until acceptance criteria have been met. However, if a significant change in the cement source occurs, sampling and testing shall be repeated.

12.6.5 Further sampling, testing and quality assurance will be as per approved 'Quality Assurance programme submitted by the Contractor.

12.7 GROUTING MATERIALS

12.7.1 All grouting materials shall require approval of engineer before their application. Contractor shall arrange to carry out all testing required to the satisfaction of engineer before seeking any approvals.

12.7.2 General

- i. The following kinds of grout mixes shall be used:
 - a. Cement grouts (OPC 53/53S and OPC based Micro/ultrafine cements).
 - b. Mineral grouts (Colloidal silica or Polyurethane).
 - c. Combination grouts: Combination of any of the above-mentioned grouts.
 - d. Admixtures (like super plasticizer, accelerators, Micro silica/Silica fume etc.) shall be added in dosage required to achieve its benefits.
 - e. Only PC based super plasticizers and alkali free liquid accelerators shall be used with OPC 53/53S, MFC, UFC etc.
- ii. All cement based grouts shall use required dosage of super plasticizers (PC based and minimum 1.5% of cement weight), accelerators (1-2% if required), Micro silica/Silica fume (1-2% if required) and other additives and shall be tested on site to achieve following properties. The tests shall be performed both initially (for

design approval) and subsequently just after preparing grout for injecting into strata (Once for each type of grout mix per shift):

- a. Marsh cone time of less than 35 seconds. (IS: 14343 Annex-A)
- b. Bleeding of less than 2% till 2 hours. (IS: 10874 Annex-C)
- c. Initial setting time of more than 120 minutes. (IS: 4031 (Part-5))
- d. Final setting time of less than 240 minutes. (IS: 4031 (Part-5))

iii. At few locations engineer may direct the Contractor to adopt lesser setting times also. This will be achieved by increasing the dosage of accelerator.

iv. The use of toxic chemicals such as acrylamide/Poly-acrylates shall not be permitted for use in the works. Pre-blended cements shall not be permitted.

v. Cement (OPC 53/53S, MFC, UFC) shall not be older than 3 months/Manufacturer's specified shelf life at the time of usage.

12.7.3 OPC 53/53S grade Cement

i. The cement shall conform to requirements of Section of “Materials for Construction” and relevant standards and shall be free from lumps. Any cement containing lumps and foreign matter detrimental to the results of grouting shall be rejected by the Engineer.

ii. Additionally, OPC 53 and OPC 53S used for grouting shall have Blaine value not less than 275 m²/kg and 370 m²/kg respectively.

12.7.4 Micro Fine Cement (MFC) shall conform to IS:10874, additionally;

i. Micro fine cement should have specific surface (BET method IS: 15388) more than 600 m²/kg and D₉₅< 15μ. Original MTC to be submitted for approval of engineer before usage. Contractor at his own cost shall get the same tested from 3rd party at direction of engineer.

12.7.5 Ultra-Fine Cement (UFC) shall conform to IS:10874, additionally;

Ultra-Fine Cement should have specific surface (BET method IS: 15388) more than 900 m²/kg and D₉₅< 12μ. Original MTC to be submitted for approval of engineer before usage. Contractor at his own cost shall get the same tested from 3rd party at direction of engineer.

12.7.6 Colloidal Silica (CS):

i. Colloidal silica shall be environment friendly, highly stable and having ultralow viscosity of less than 6 mPA.s at 25°C.

ii. Gel time of Colloidal silica shall be adjustable from 60 minutes to 10 minutes by increasing the accelerator dosage.

12.7.7 Water

i. Water shall not contain more than 2 parts per thousand of suspended colloidal solids and no particles larger in size than the cement particles. It shall not be

aggressive. The chloride content shall be less than 50 mg per liter and the sulphate content less than 100 mg per liter.

- ii. The temperature of water used for the preparation of grout shall not exceed 25⁰c.

12.7.8 Admixtures

- i. Admixtures shall be added to grout mixes to optimize the strength, viscosity, density, decantation, setting time and shrinkage.
- ii. Only admixtures proved by testing prior to the start for grouting shall be used. Manufacturer's certificates or guarantees will not be accepted as relieving the Contractor of his responsibility for the suitability of any admixture. Admixtures shall conform to the relevant IS code.
- iii. Liquid accelerators shall be alkali free and if required shall be added only through dedicated nozzle into the grout line at the face (1-2% by weight of cement).
- iv. Super plasticizers shall be PC based only (minimum 1.5% by weight of cement).
- v. Micro silica/Silica fume shall be added 1-2% by weight of cement if required.

12.7.9 Polyurethane (PU)

- i. The products used in chemical grouting should be non-toxic, solvent free, eco-friendly and present low viscosity. Polyurethane foam resins, polyurethane resins and silicate foam resins can be used depending on the purpose and aim of the grouting.
- ii. Polyurethane (combined systems) shall be used for consolidation of the sheared or disturbed rock, loose material, or for making the ground impermeable against water inflow even under high pressure. PU is two component system having high fire resistance, low flammability and extremely fast curing. The system should be capable of being designed to behave as foaming or non-foaming in the presence or absence of water.
- iii. For consolidation grouting: A polyurethane resin with low viscosity, a large penetration factor and high compressive strength should be used. Foam factor should be less than 4 (4 times its original size).
- iv. For waterproofing and control of high ingress of groundwater: A polyurethane foam resin with low viscosity and a large foam factor (approx. 40) with a fast reaction in contact with water should be used.
- v. Accelerators should be used. The ratio accelerator/resin should be tested and calibrated in a trial test to optimize the penetration rate according to the needed depth of the treatment.
- vi. It is advised to test the optimized mix for a situation where a weak sheared/fault zone is bearing high inflow and a quick stoppage of the water is required at the same time that a consolidation of the rock. A high foam factor reacts rapidly with the water but reduces compressive strength and decreases penetration capacity.

Thus, a trial test should be carried out to define the best combination for each situation.

- vii. The results of these tests should be confirmed with core drillings to evaluate the penetration capacity of the resins.

12.7.10 Other Chemicals

When other chemicals are required or proposed, they shall be accompanied by the manufacturer's certificates that they have been commercially used with satisfactory service in the similar type of work. The storage, handling and usage shall be strictly with the manufacture's printed instructions.

12.8 GROUT MIXTURES

- 12.8.1** The type of grout and proportions of various constituents in the grout mixtures shall be as directed by Engineer and shall be constantly adapted to the conditions on the site as the Engineer may direct.

- 12.8.2** Any grout mixture not used within one hour after mixing shall be rejected.

12.9 DRILLING AND GROUTING EQUIPMENT

12.9.1 General

- i. Only modern, properly operating drilling and grouting equipment approved by the Engineer and operated by trained and experienced crew shall be used for the performance of the work.
- ii. Drilling equipment of the rotary or percussion type shall be used to perform the drilling as specified herein and as required by the Engineer.
- iii. Percussion type drilling equipment shall be equipped for continuous washing of holes during drilling.
- iv. All Drill booms on jumbo shall be equipped with sensors to record measurements while drilling (MWD) to record the drilling data.
- v. The washing and water pressure testing plant shall include pumps, gauges, valves and all other accessories necessary to complete the works as specified. The pumps shall be of the gear, centrifugal or other acceptable types and shall be capable of maintaining constant pressure. The Contractor shall supply water storage tanks sufficient for the pumps in addition to flow meters and pressure gauges for calibration and checking purposes. The arrangement of injection equipment must include a return circuit, conveniently designed so that the grout or mortar can circulate continuously along the pipe, in order to avoid clogging and concurrently allowing an accurate pressure control into the hole. During grouting process, grout should always remain agitated. The distance between the injection pump and the injection hole should not be more than 50 meters. All the grout or mortar dosing and injection equipment must always be kept in optimal operating conditions and calibrated periodically. The entire circuit should be

prepared to be washed in case of clogging by means of “T” fittings and water connections.

- vi. Grouting equipment shall consist of grout pumps, weighing scale for additives and cement, grout mixers water meters, agitator sumps, pressure gauges, packers, pipelines and fittings, and miscellaneous tools, and shall be specifically designed for grouting purposes.
- vii. Grouting equipment shall be capable of effectively mixing and stirring the grout and forcing it into the grout holes or grout convections in a continuous, uninterrupted flow at any specified pressure up to maximum of 100 bar, accurately measuring the grout intake, and maintaining the specified pressure for at least 5 minutes after the hole refuses to accept further grout. The equipment shall be capable of accurately controlling grout flows and pressures and shall be suitable for neat cement, cement sand, and chemical grouts.
- viii. Spare gauges, valves and fittings shall be kept available on the Site, and a two-way communication system between the mixing plant and place of grouting shall be provided if the distance exceeds 60 m.
- ix. Standby equipment, which can be activated immediately, shall be furnished to ensure continuity of work in the event of main equipment breakdown. The standby equipment shall be able to operate at pressures up to 100 bar.
- x. Prior to commencement of the work, during the work as specified or as requested by the Engineer, and at the end of the work, all pressure gauges, recorders and discharge meters shall be checked and calibrated.
- xi. The grouting equipment shall be maintained to the satisfaction of the Engineer in order to guarantee continued and efficient performance during grouting work.

12.9.2 Deleted.

12.9.3 Recording of data for grouting

- i. Recording of data shall be automatic through an electronic data logger (a PC), which shall have facility to actively control the entire process.
- ii. Control parameters such as maximum allowed injection pressure, maximum and minimum flow rate and maximum quantity of grout per injected hole shall be entered into the PC.
- iii. PC shall then record the process automatically, and also stop the pump when any of the stop criteria have been reached. When injecting on several holes simultaneously (with one pump per line) this equipment is a great help in keeping things under control and receiving accurate recordings, without the need for more staff.
- iv. It should be possible to see the cumulative grout volumes and grout material weights injected inside the hole under grouting operation.
- v. Pressure transducer and an inductive flow meter shall be coupled into the grouting line.

- vi. Print out of grouting rig log shall be submitted with grouting reports after each grouting operation.

12.9.4 Grout Mixers and Agitator sumps

- i. Grout mixers for mixing the stable mixtures shall be of the mechanically operated, high speed colloidal type of sufficient size, and operating at 1500 to 2000 rpm with electric or pneumatic drive to ensure complete dispersion and activation of the mix.
- ii. Hand powered mixers or concrete mixers shall not be permitted for preparation of grout mixtures.
- iii. Mix shall be weighing batched and mixers shall be provided with equipment for measuring weight and volume of mix components with an accuracy of 2 % and a water meter calibrated in liters with a reset switch for zeroing after each delivery.
- iv. After mixing, the grout shall be discharged through a 5 mm mesh screen into an agitator sump equipped with stirring paddle to prevent settling and to remove any air bubbles from the mix. The stirring paddle shall be of such arrangement to guarantee a complete circulation of the entire sump content. The agitator sump shall have double the capacity as of the mixer so that one batch of grout can be pumped while the next batch is being mixed.
- v. Grouting rig shall be equipped with computerized controls and automatic logging of entire grouting operations (volume of different recipes injected in each hole, pressure at which the injection took place, pressure build up/loss as the grout is run, start and stop time for different mixtures).

12.9.5 Grout Pump

- i. Grout pump should be able to inject grout at upto 80 bars steady pumping pressure for upto 20 L/min of constant flow, simultaneously into 2 holes at the same time.
- ii. Pumps shall be of the duplex double acting piston type. The pump body shall be of high wear and shock resistant material. The plunger unit shall be of stainless steel, highly resistant to abrasion.
- iii. The pump shall have hydraulic drive.
- iv. The pumps shall be equipped with precise pressure and capacity control valves, which allow the setting of both, the maximum pressure and the flow independently. The pump shall automatically stop whenever the preset pressure is reached and shall maintain the pressure without fluctuation.
- v. For works requiring a small volume of grout such as crack grouting or rock bolts grouting, the Contractor may use hand operated grout pumps approved by the Engineer. These pumps shall be able to achieve a pressure of up to 25 bar.

12.9.6 Pressure Gauges

- i. The Contractor shall provide pressure gauges for both low and high-pressure ranges (0- 20 bar and 20 -100 bar). Two gauges of the appropriate range shall be provided in each grout line, one at the pump for the use of the pump operator, the other at the hook up connection directly at the collar of the hole. The required pressure for each particular hole shall be measured on the hook up pressure gauge, not at the pump.
- ii. Pressure gauges shall have an accuracy of 3%. A minimum of two standardized pressure gauges for each range shall be calibrated and certified by an independent laboratory prior to the commencement of grouting works. One gauge for each range shall remain at the disposal of the Engineer, and the other shall be, used by the Contractor for checking and calibration of working gauges. Working gauges shall be used for no longer than 2 shifts before being cleaned and recalibrated. All working gauges shall have reference number for identification, which shall be quoted in the grouting reports to be submitted to the Engineer.

12.9.7 Connections to Grout Holes and Packers

- i. Supply and return lines equipped with quick release couplings shall be able to withstand an internal pressure greater than the maximum produced by the pump. The internal diameter of the lines shall be such that no appreciable settlement of grout takes place when pumping at the minimum discharge capacity of the pump.
- ii. Valves shall be provided at the pump, in supply line and at the collar of the hole being, grouted. Suitable screens shall be incorporated in the supply line for removing oversize particles and foreign matter before injection into the grout hole.
- iii. Packers shall be the same as used for water pressure testing and shall be of the mechanical rubbing ring or pneumatically expandable rubber types. These shall be capable of sealing holes without leakage. These packers shall be capable of being used either single or double. Double packers shall be separated by up to 3 m of perforated pipe. The diameter of pipes used for separating and placing the packers in holes shall be the maximum possible for the size of the holes.

12.9.8 Embedded Pipes and Fittings for Grouting

- i. Whenever pipes are required to be installed, Standard mild steel pipes and fittings for grouting shall be set in the rock and concrete as directed by the Engineer. The pipes and fittings embedded in concrete shall be cleaned thoroughly of all dirt, grease, grout and mortar immediately before embedment and shall be firmly held in position and protected from damage of displacement while the concrete is being placed. The size of the pipes embedded in concrete lining for drilling holes for grouting shall be of a suitable internal diameter. A standard coupling and nipple wrapped to facilitate eventual removal shall be attached to the grout pipe where embedded in concrete. No portion of the pipe

shall be allowed to remain within 50 mm of the concrete surface and the resulting recess, after removal of the pipe or fitting, shall be filled with dry pack mortar.

- ii. Care shall be taken to avoid premature blockage of pipes. Any pipe that becomes blocked before completion of operations shall be cleaned in a satisfactory manner or replaced by the Contractor

12.9.9 Maintenance routine

- i. Thorough cleanup must be performed to prevent cement from hardening in production apparatus and in the grouting rig. Such maintenance must be facilitated by ensuring that a high-pressure washer and a work bench are available in the vicinity of the grouting rig. Following is the advisory schedule which may be followed: -

Component	Maintenance frequency	Comments
Hoppers	Feed screws should be checked regularly and cleaned when necessary. Hoppers must be emptied in the event a prolonged stoppage.	The screw can be checked when the hopper is run to empty.
High-speed mixer	Cleaning after each round of grouting. Impeller/paddles should be replaced every other year.	Thorough cleaning is vital. Inadequate cleaning may result in set cement falling into the cement being mixed and causing operating problems during grouting. Impeller/paddles/knives will become worn and gradually give poorer mixing results. They should be replaced when they no longer give the same shear force in the mixing process.
Stirrer (agitator)	After each round of grouting.	Thorough cleaning will prevent a buildup of cement, also at the top of the mixer. All surfaces must be checked.

Component	Maintenance frequency	Comments
Grouting pump	After each round of grouting.	Must be dismantled, cleaned and lubricated internally with acid-free vaseline.
	After each round of grouting.	Check of wear on connecting pieces, threads and split pins.
	After each round of grouting.	Check for wear and damage. Damaged hoses must be replaced.
Grouting rods	After each hole.	Thorough cleaning and lubrication of threads.
Packers	Check the packers that are going to be used before each round of grouting.	Check there are no production faults in the locking mechanism.
Taps/Ball valves	After each hole and during grouting. When grout takes are large, functionality should be checked by opening the tap.	Important to check functionality, particularly of pressure relief valves.
Grouting rig	Regular cleaning/lubrication, at a minimum after each round of grouting.	Anti-seize oil should be applied after rig has been washed. It is advantageous if the rig is equipped with a high-pressure washer for continuous cleaning during the grouting process.
Scales	Every other month, or after 200 tonne.	Measuring cells should be checked.

12.10 DRILLING OF HOLES**12.10.1 General**

- i. The number of holes to be drilled, their location, sequence, orientation, inclination and the depth shall be as per approved methodology.
- ii. All holes shall be established within 0.10 m of the specified location. Maximum deviation for holes shall be 2° (degree) from the proposed values.
- iii. If for any reason, the drill hole deviates in inclination or orientation in such a way that it does not satisfy the purpose for which it was intended, the Contractor shall correct the deviation or shall drill another hole to the satisfaction of the Engineer.
- iv. Hole size for probing and consolidation grouting holes (Drilled in the face) shall be kept same.

12.10.2 Drilling of Holes for Rock bolts, Exploration and Instrumentation and other than Grouting, etc.

- i. The minimum diameter of holes shall be 38 mm or as directed by the Engineer.
- ii. Holes shall be drilled either directly into the rock or through the concrete lining and then into rock as directed by the Engineer.
- iii. The holes shall be drilled in a direction normal/inclined to the surface of the underground excavation / concrete lining as the case may be or as directed by the Engineer.
- iv. While drilling the holes, utmost care shall be taken to ensure that the reinforcement or structural ribs, if any, in the concrete lining, shall not be cut through. The position of steel ribs shall be recorded and marked on the finished concrete lining. If the reinforcement or steel ribs are encountered during drilling of any holes in concrete, drilling shall be discontinued immediately, and a new hole shall be drilled nearby. The holes so abandoned shall be backfilled with concrete as directed by the Engineer and the surface of concrete shall be repaired.
- v. Each hole shall be protected from becoming clogged or obstructed by a grout connection pipe fixed suitably into the holes and the holes shall be suitably capped or otherwise protected until these are grouted. Any hole that becomes obstructed before being grouted shall be cleaned out in a satisfactory manner.
- vi. The use of rod dope, grease or other lubricants on drill rods shall not be permitted and no drilling water additives of any kind shall be used without the approval of the Engineer.
- vii. Whenever the drilled water is lost or artesian flow is encountered, drilling operations shall be stopped, and the hole shall be grouted before drilling operations are resumed. The Contractor shall record the location, flow and the pressure of any artesian conditions encountered in any drill hole.

12.11 FLUSHING OF HOLES

- 12.11.1** On completion of drilling, all holes shall be thoroughly flushed to remove any accumulation of fines, sludge, or foreign materials. Holes shall be flushed out by water at pressure of 10 bar, combined with some compressed air injected through a stiff plastic hose starting at the bottom of the holes. Contractor shall continue flushing for two minutes after the return water becomes clear.
- 12.11.2** For grout holes, flushing will also be required immediately before water testing/high pressure grouting. A custom designed diesel-powered piece of equipment shall be used to provide a water jet pressure of upto 100 bar. The high-pressure water hose shall have nozzle arrangement so that some water jets pointing 45° back along the hose and others at 90° radially. With this configuration, the nozzle is self-propelled forward into the hole and can be removed by just pulling the flexible hose.
- 12.11.3** If there are zones in the borehole that may collapse if soaked in water, or will be excavated by the flushing jet, or if the water yield from the hole is more than 10 l/min, the flushing may be omitted.
- 12.11.4** Flushing of boreholes for grouting should be done as specified as a routine matter and any necessary deviations should be decided on and recorded by the supervisor, based on the borehole records.

12.12 GROUTING OPERATIONS**12.12.1** General

- i. All pressure grouting operations shall be performed in the presence of the Engineer.
- ii. In the underground works, the grouting works, and other operations shall be carried out as per approved working methodology or directed by the Engineer.
 - a. Consolidation grouting and impermeabilization of the rock ahead and around the heading face as needed before further advance.
 - b. Fill grouting of exploratory and drain holes, which may be required during underground excavation, prior to placing of concrete lining.
 - c. Contact grouting in the crown of the tunnel and cavern after placing of concrete lining.
 - d. Fill grouting of drainage conduits and sump pits.
 - e. Depending on the rock conditions, the Engineer may direct to carry out Consolidation grouting.
 - f. Control grouting.
 - g. Installation of one-way checks valves.
 - h. Crack grouting as directed.
- iii. The above sequence is not exhaustive, and the Contractor shall plan his operations in such a way that he is flexible to adapt to the conditions encountered.

- iv. The utmost care and precautions shall be taken to ensure that the concrete does not get damaged during the grouting operations.
- v. If the Engineer considers necessary to carry out an additional grouting in any section of the works, the Contractor shall reinstall the necessary equipment and perform the grouting to the satisfaction of the Engineer.

12.12.2 Contact Grouting between Concrete and Rock where concrete lining is required to be installed

- i. Low pressure contact grouting shall be carried out between concrete and rock over the entire length of the tunnel to fill voids between the rock surface and the following:
 - a. Structural concrete in the crown of the tunnel and cavern and in the concrete plug in the tunnels.
 - b. Concrete in any other zones within the underground works where conditions so require and as the Engineer may direct.
- ii. Contact grouting shall normally be performed from holes drilled in the crown of the tunnel, shaft and cavern and shall be carried out in advance of consolidation grouting operation.
- iii. Contact grouting in the completed concrete plug in access and it shall be performed through the pipe system cast into the body of the plug as specified in Section of "Cement Concrete".
- iv. Water pressure testing will not be required prior to contact grouting.
- v. In any section of the underground structure, the concrete lining within 100 m of that section shall have been in place for at least 21 days before grouting commences.
- vi. Contact grouting shall be carried out at low pressure (not exceeding 5 kg/sq.cm) using a cement-sand grout and shall continue until all voids are filled. Vent pipes for the release of air and water during grouting shall be provided in locations as shown in the drawings, as directed or approved by the Engineer.
- vii. After the grouting of any hole is completed, the pressure shall be maintained, by means of stopcock or other suitable device, until the grout has set.
- viii. Control grouting shall be carried out, where directed by the Engineer, to verify that voids have been completely filled with grout. Grouting will be regarded as being satisfactory if the pressure can be maintained for at least 5 minutes without grout intake.

12.12.3 Closure of Holes and Clean-up

Upon completion of grouting work, each hole shall be filled with thick grout and connections not embedded in the concrete shall be removed. The drilled holes in the concrete lining shall be reamed or redrilled to a depth corresponding to the $\frac{2}{3}$ rd of

theoretical concrete lining thickness and filled with dry pack mortar, as stipulated in Section of “Cement concrete”, flush with the concrete surface.

12.12.4 Crack Grouting

- i. Crack grouting shall be performed to seal the cold joints, construction joints, shrinkage cracks, honeycombs, poorly closed grout holes etc., in the structural concrete lining of underground structure as directed by the Engineer and as stipulated in Section of “Cement Concrete”.
- ii. Crack grouting shall consist of injecting a stable, cement water mix with admixture through holes specially drilled into cracks or joints.
- iii. Preventive measures shall be taken by plugging the joint with wooden wedges, cardboard; cement-gypsum mortar or other suitable mean to prevent the grout from flowing out of the crack.

12.12.5 Curtain Grouting

- i. Curtain grouting shall not be started until consolidation grouting has been completed within 60 m radius around the curtain holes to be grouted.
- ii. Drill holes for curtain grouting shall be drilled and grouted in three stages consisting of Primary, Secondary and Tertiary holes. Primary holes shall be drilled, washed, subjected to water pressure testing, when required by the Engineer, and grouted before proceeding to execute the secondary holes. The depth of holes and spacing between them shall be as shown on the drawings or as approved by the Engineer.
- iii. Unless otherwise specified by the Engineer, curtain grouting shall be done in stages of 5 m each.
- iv. If grout absorption in any 5-meter stage, which is not caused by leakage at the surface, is found to be excessive in adjacent primary and secondary holes, the Engineer may require the Contractor to drill and grout additional holes (tertiary holes) between the primary and secondary holes.

12.12.6 Water Pressure Testing

- i. Water pressure tests with double packer apparatus having a perforated pipe not less than 1.5 m shall be carried out on the grout holes when directed by the Engineer. The actual spacing will be determined by the Engineer. Water pressure shall than be applied to the test section for a minimum period of 5 minutes.
- ii. The maximum pressure for water testing shall correspond to the pressure specified for grouting. Water loss shall be measured in liters.
- iii. Based on the results of the water pressure tests, the Engineer may require additional grouting. Such grouting shall be, carried out by the Contractor at the pressure specified by the Engineer.

Chapter 13

Earthwork in Formation

13.1 FORMATION IN EMBANKMENT/CUTTING

Earthwork in formation and blanketing shall be carried out as per RDSO specification No. RDSO/2020/GE: IRS-004 September 2020 “Comprehensive Guidelines and Specifications for Railway Formation” and in accordance with the approved drawings.

The Contractor shall utilise excavated earth/rock from tunnel/cutting for formation in the stretch from Ch. 12000 m to Ch. 18000 m. For the balance earthwork, the Contractor shall arrange suitable borrow areas at his own cost and get them approved from the Engineer before using soil from such borrow areas.

Soils mentioned in Clause 3.7 (a) of the RDSO Guidelines shall not be used.

SQ-1 type of soils shall not be used in prepared subgrade and top layer of subgrade.

MDD in laboratory shall be determined by using Heavy Proctor test as per IS 2720 Part-16.

MDD achieved in the field compaction trial shall not be less than 98% of the MDD achieved in laboratory.

Degree of compaction of soil in prepared subgrade/top layer of subgrade shall not be less than 98% of MDD achieved in field as a result of Field Compaction Trial.

After completion of earthwork slope shall be dressed in final profile by cutting the extra earth and compacted with vibratory rollers of approved capacity and make as per RDSO guidelines.

Blanketing material shall be as per RDSO Guidelines.

The type of test, frequency and acceptance criteria for quality check of earthwork and blanketing shall be as given in Chapter 7 of RDSO Guidelines.

Before laying the coir netting for slope protection, the slope shall be levelled, fertilised and a dose of seed broadcasting of locally available suitable type of grasses shall be done. Thereafter, coir netting shall be laid on the prepared slope surface firmly in the direction of water flow and flushed to the ground ensuring that the runoff would flow over the nettings. The netting shall be secured against displacement by an overlapping of 5 cm to 8 cm and stitched or pegged down with 15 cm long steel nails about 1 .0 m apart. The top and bottom ends of the fully stretched coir netting shall be fixed/anchored in trenches of 50 cm depth. Afterwards, another dose of seed broadcasting or dibbling of locally available grasses 15 to 20 cm apart, in rows shall be carried out.

NP-4 pipe of 450mm diameter, conforming to IS 458, shall be provided at about 500m interval throughout the alignment in embankments having fill heights upto 5m *including ballast cushion of 350mm*. In embankments having fill heights more than 5m *including ballast cushion of 350mm* precast RCC box of 500mmx500mm clear size shall be provided for the purpose of future utilities. Installation conditions for the pipe shall be designed as per the IS-783, according to the fill height.

Site drains, catchwater drains, drains on berms, chutes on slopes of banks/cuttings, sumps shall be constructed as per approved drawings in accordance with the Annexures OCS-1 and OCS-2.

Chapter 14**BRIDGES****14.1 General****14.1.1 Scope of Specifications**

This specification shall be applicable for carrying out bridge works.

14.1.2 Applicable Standards

The applicable standards shall be as follows:

a) Indian Railway Standard Codes and Specifications (IRS)

- i. Bridge Rules
- ii. Concrete Bridge Code
- iii. Steel Bridge Code
- iv. Well and Pile Foundation Code
- v. Fabrication Specification No. B1-2001
- vi. Specification No. B-2 for Steel Structures (other than Girder Bridges)- Part 3.
- vii. Welded Bridge Code
- viii. Bridge Sub-structure & Foundation Code
- ix. Specification No.M-28, Classification, testing and approval of metal arc welding electrodes for use-Indian Railway
- x. Specification No.M-29, Classification, testing and approval of submerged arc welding with flame combination
- xi. Indian Railways Unified Standard Schedule of Rates - 2019
- xii. Indian Railways Unified Standard Specification (Formation Works, Bridge Works & P.Way Works) - 2019
- xiii. Indian Railways Permanent Way Manual (IRPWM)
- xiv. Indian Railways Works Manual (IRWM)
- xv. Indian Railways Bridge Manual (IRBM)
- xvi. Indian Railways Engineering Code
- xvii. Manual on the design and construction of Well and Pile foundations
- xviii. Indian Railways Schedule of Dimensions (BG)
- xix. IRS Seismic code for Earthquake Resistant Design of Railway bridges.

b) RDSO Guidelines

- i. BS-113 Guidelines for providing Arrangements for Bridge Inspection
- ii. Comprehensive Guidelines and Specifications for Railway Formation:

RDSO/2020/GE: IRS 0004.

- iii. Report No. GE: R-50: Transitional System on approaches of bridges
- iv. Report No. BS-111: Guidelines for use of High Strength Friction Grip (HSFG) bolts on bridges on Indian Railways
- v. Guidelines for design of Spherical and Cylindrical bearings (in case of Steel Bridges).- RDSO/CBS/Bearing dated 22-06-2011
- vi. RDSO drawings for H-beam sleepers
- vii. Report No. BS 115 : Guidelines for Composite Construction Including Stud Shear Connectors

c) Indian Standards Codes and Specifications (IS)

- i. IS: 456 Plain and reinforced concrete - code of practice
- ii. IS: 800 Code of practice for General Construction Steel
- iii. IS: 875 Code of Practice for Design Loads Part 1, 2 3, 4& 5 (Other than Earthquake)
- iv. IS: 1080 Design and construction of shallow foundations in soils (other than raft ring and shell)
- v. IS: 1367 Technical Supply Conditions for Threaded Steel Fasteners
- vi. IS: 13920 Ductile detailing of reinforced concrete structures subjected to seismic forces code of practice
- vii. IS: 1489 Specification for Portland pozzolana cement (Fly ash based)
- viii. IS: 1786 High strength deformed steel bars and wires for concrete reinforcement
- ix. IS: 1904 Design and construction of Foundations in soils: general requirements.
- x. IS: 2062 Specifications for weldable Structural steel
- xi. IS: 2502 Code of Practice for Bending and Fixing of Bars for Concrete Reinforcement
- xii. IS: 2911 Design and Construction of Pile Foundation - Code of practice Part1 Concrete Pile- Section 2 Bored Cast-in-situ-piles
- xiii. IS: 2911 Design and Construction of Pile Foundation- Code of practice Part1 Concrete Pile- Section 4 Precast Concrete Piles in Prebored Holes
- xiv. IS 2911 Design and Construction of Pile Foundation- Code of practice Part 4 Load test on piles
- xv. IS: 2950 Design and construction of raft foundations
- xvi. IS: 3935 Code of Practice for Composite Construction
- xvii. IS: 4923 Hollow steel sections for structural use -specification

- xviii. IS: 1161 Steel Tubes for Structural Purposes- specifications
- xix. IS: 8009 Calculation of settlements of shallow foundations
- xx. IS: 269 Specifications of OPC cement
- xxi. IS: 9103 Specifications of Concrete admixtures
- xxii. IS: 12070 Code of practice for Design and construction of shallow foundation on Rocks
- xxiii. IS: 14593 Design and Construction of Bored Cast-in-Situ Piles Founded on Rocks.
- xxiv. IS 455 Specifications for portland slag cement

d) Other Standards

- i. CPWD specifications, (Vol 1 & 2) -2019
- ii. Delhi Schedule of Rates, (Vol 1 & 2) - 2021
- iii. UIC Code 772-2 (R) Code for the use of rubber bearings for rail bridges
- iv. IRC:83-2018 (Pt. II) - Standard Specifications and Code of Practice for Road Bridges (Section – IX) Bearings (Elastomeric Bearings)
- v. IRC:83-2014 (Pt. IV) - Standard Specifications and Code of Practice for Road Bridges (Section – IX) Bearings (Spherical and Cylindrical)
- vi. ISO 6892 – Tensile Testing of Metallic Materials
- vii. ISO 13918-2008 – Welding- Studs and Ceramic Ferrules for Arc Stud Welding

14.2 Bridge Works: Substructure

14.2.1 GENERAL

a) Coverage

The Specifications given in this chapter deal with items pertaining to all types of foundations for bridges and bridge superstructure viz., Piers, abutments, wing walls, bed blocks and ballast walls / dirt walls.

14.2.2 Setting out for foundations

a) Setting out for Minor Bridges and Culverts

shall be carried out by a competent / qualified engineer, employed by the Contractor and checked by the Engineer's representative for all bridges and culverts. Contractor shall provide necessary instruments, linear tapes, pegs etc.

The setting out for foundations and sub-structure shall be carried out with a theodolite and steel tapes / Invar tapes in case of works not involving deep foundations or standing water. All levels will be measured using a precise

levelling instrument. Errors in location of piers / abutments and fixing levels shall be within following limits:

Linear Measurements	±5 mm
Levels	±3 mm

b) Setting out for Major Bridges

- i. Locations of piers and abutments along with the centre line of the bridge should be accurately laid out by establishing one or more base lines as directed and a system of pegs and posts. Also sufficient reference pegs and pillars should be established for checking the positions with ease during progress of work. Reference Bench Marks for levelling should be established nearby on a permanent structure or on a pillar to be built up in vicinity.
- ii. The principal reference lines and level pegs should be established at easily accessible locations. They include-
 - 1) Longitudinal Centre line
 - 2) Transverse Centre lines of abutments and piers
 - 3) Tangent points of the curve at either end, if alignment is on a curve.
- iii. For Bridge Works involving deep excavations, pile driving or well sinking and / or where there is standing water, use of base line is obligatory. They should be preferably at right angle to centre line of bridge, with one on either end on high bank in case of long bridges or on one side bank of bridge for shorter ones.
- iv. In case of bridges of length exceeding 1000 Metres, base lines and reference towers will have to be established. Provision of all assistance in form of measuring instruments, linear tapes as may be required by the surveyor, technical and skilled staff and labour required to assist them, fixing pegs, pillars and towers including all building materials and maintaining and guarding them including supply of all materials, tools and plant shall be done by the Contractor at his cost. Nothing extra will be payable to them on this account. Important points to be observed in this activity are:
 - 1) Linear Measurement shall be carried out with invar tape or electronic distance measuring instruments
 - 2) Spring balances shall be used for giving specified tension to the tape. Tape readings shall be corrected for tension, temperature and slope.
 - 3) Concrete pillars with steel plates fixed over them shall be located at intermediate points (at tape lengths) and ends.
 - 4) Reference pillars at pier and abutment position along centre lines and reference pillars on base lines shall be to standards to be prescribed by the Engineer. During construction, since centre line pillars at abutment

/ pier locations will be disturbed, reference pillars and lines shall be fixed around each structure by the Contractor under Site Engineer's supervision. Reference diagrams at Annexures 4/1 and 4/2 and Clause 401 of IRBM shall be referred to for more details.

14.3 Soil Exploration

Soil exploration and test shall be carried out conforming to Indian Railways Codes and Specifications according to soil type, foundation type and site requirement.

14.4 Earthwork in excavation

Excavation shall be made only to the exact depth as shown on the drawings. In the event of excavation having been made deeper than that shown on the drawing or as ordered by the Engineer, the extra depth shall be made up with M10 concrete in case of foundation resting on soil and with concrete of the same grade as that of the foundation, in case of foundation resting on rock.

14.5 Method Statement

The Contractor shall submit Method Statement for carrying out the work of excavation in foundations and flooring etc. suiting to local ground conditions and safety measures conforming to IS: 3764 (Excavation Work- Code of Safety) to the Engineer for approval. The work shall be carried out strictly in accordance with the approved Method Statement and drawings.

14.6 Site Clearance

Site clearance shall be done as per the Contract.

14.6.1 Setting Out

After the site has been cleared, the limits of excavation shall be set out true to lines, curves, slopes, grades and sections as shown on the drawings or as directed by the Engineer. The Contractor shall be responsible for the setting out of works and the establishment and maintenance of benchmarks, other marks & stakes as long as in the opinion of the Engineer, they are required for the work.

- a) Excavation shall be carried out in all types of soil encountered at site and to the lines, levels and profiles shown on the drawings that have NONO from the Engineer. The Work shall be carried out by the Contractor in such a way as to avoid soil erosion and groundwater pollution, accidents in habitational or frequented places, disturbance to the surrounding ground or structures, accident to workmen and any other untoward incident. Fencing, caution signages with red lights and other safety measures shall be employed to avoid accidents. Where necessary, signal men shall be employed to guide the movement of people, vehicles and equipment.
- b) The work shall be carried out in a careful manner to ensure that the exposed surfaces are as sound as the nature of the material permits and that no point shall protrude inside the lines shown on the Drawings.

- c) The Contractor shall be responsible for the safety and stability of all excavations performed by him or under his control. In case of any slips or blows in the excavation, the same shall be cleared by the Contractor at his own cost.
- d) The Contractor shall notify the Engineer without delay of any permeable strata, joints, faults, fissures or unusual ground conditions encountered during excavation and any excavation instability and/or collapse.
- e) The Contractor shall ensure that no air pollution takes place during excavation, storage and transportation of earth/spoil by providing suitable measures such as appropriate cover and the like.
- f) The Contractor shall carry out ground stabilization measures without delay before and/or after excavation, if required.
- g) The Contractor shall make provision for all shoring, de-watering, dredging, bailing out or draining water whether subsoil or rain or other water and the excavation shall be kept free of water while concrete work is in progress until the Engineer considers the work well set. The sides of trenches shall be kept vertical and the bottom level throughout or properly stepped as directed by the Engineer. No extra payment shall be made on this account.
- h) De-watering shall be carried out by suitable means with adequate stand-by arrangements as may be approved by the Engineer. The Contractor shall be deemed to have satisfied himself with regard to feasibility of all aspects of de-watering including site constraints due to existing structures. Though the method of de-watering is left to the Contractor, he shall be required to submit method statement of de-watering scheme including requisite justifications to obtain approval from the Engineer.
- i) Approval of the Engineer, however, shall not relieve the Contractor of the responsibility of adequacy and appropriateness of de-watering and protection arrangements for the quality and safety of the work.
- j) The Contractor shall erect and maintain during progress of works temporary fences/ barricading around the work area with all safety measures as shown in Reference Information/Reports. The excavations near habitations, public movement areas and all works along the roads shall be provided with proper caution signs and marked with red lights, reflectors at night to avoid accidents. The Contractor shall take all adequate protective measures to see that excavation operations do not affect or damage adjoining structures.
- k) Disposal of muck: The surplus excavated material (that cannot be used in the Works), shall be treated as Contractor's property. The Contractor shall be free to take away and make use of this surplus excavated material in the manner he wishes to, including disposal in spoil dumps or elsewhere as approved by the Engineer/concerned parties and regulating authorities. The Employer takes no responsibility for the arrangement of dumping areas and these will have to be arranged by the Contractor at his own cost. The Contractor is required to carry out detailed survey to identify dumping areas, clearances required, leads

involved etc. The quoted rates shall be deemed to have taken all these factors into account. The excavated material that can be used in the Works, shall be temporarily stockpiled, if required, in a dump site as proposed by the Contractor and agreed by the Engineer and the concerned regulating authorities. Any royalty, if to be paid to local authorities on the excavated material, is to be borne by the Contractor at his own cost irrespective of whether the excavated material is used for the Works or being used for any other purpose or being disposed off as surplus. Truck drivers shall be trained and educated by the Contractor to follow the traffic rules.

- l) The Contractor shall ensure that traffic management on roads and railways is carried out in accordance with the *Employer's Requirements*.

14.6.2 Excavation beyond True Lines and Levels

If due to any cause whatsoever excavations are carried out beyond their true line and level, the Contractor shall make good excavation at his own cost to the required line and level with the appropriate grade of filling or with concrete subject to the NONO from the Engineer.

14.6.3 Backfill to Structures

- a) Prior to commencement of backfill, the Contractor shall submit Method Statement for carrying out work such that the optimum use may be made of excavated material and obtain approval from the Engineer. The proposals shall include details of the compaction plant and methods for adjusting the moisture content of the material.
- b) No filling shall commence until approval has been received from the Engineer.
- c) The Contractor shall not backfill around structures until the structural elements have attained adequate strength.
- d) The backfill material shall be selected excavated material, thoroughly compacted mechanically in layers not exceeding 300mm loose thickness to achieve a density of at least 90% of the maximum dry density.

14.6.4 Tolerance

Permissible Tolerance for excavation

Item	Standard value (mm)
Finished depth of excavation	±25
length/width	0 to +50

14.7 Bored cast in-situ Piling

Piling shall be carried out by hydraulic piling rig.

14.7.1 Method Statement

The Contractor shall submit Method Statement for carrying out the work of piling. The work shall be carried out strictly in accordance with the approved Method Statement, Manual on the design and construction of Well and Pile foundations, the Specification and the Drawings.

14.7.2 Materials**a) Concrete**

Piles shall be constructed in accordance with the details shown in the drawings using the grade of concrete indicated, produced and placed in accordance with provisions of Annexure OCS-1 of these specifications.

b) Reinforcement Steel

Reinforcement steel shall comply with the provisions of **Annexure OCS-2** of these specifications.

c) Temporary Casings

Temporary casings, as approved by the Engineer, shall be used to maintain the stability of pile bore hole. Temporary casings shall be free of distortion and shall be of uniform cross-section throughout each continuous length. During concreting, they shall be free of internal projections and encrusted concrete which may prevent proper formation of the pile.

d) Stabilizing Material

The stabilizing material to maintain the sides of pile bores shall preferably be natural drilling mud. If natural mud is not available, then stabilizing fluid having bentonite, controlled with a polymer like CMC (Carboxyl Methyl Cellulose), shall be used. The stabilizing material shall be approved by the Engineer. Bentonite, when used, shall conform to IS 2911 (Part 1/ Section 4).

14.7.3 Pile Installation**a) General**

- i. Bored cast-in-situ concrete piles shall conform to IS 2911 (Part 1/ Section 2), where not contravening to the following provisions. Based on borehole reports and drawings, installation of piles shall be carried out as per pile layout drawings, installation criteria, approved Method Statement and instructions of the Engineer. Any changes to the pile design, based on test-piles results, bore-hole data or soil conditions encountered during boring, shall be as instructed by the Engineer.
- ii. The equipment and accessories for installation of piles shall be selected giving the due consideration to the sub-soil conditions, ground water conditions and type of founding material. These shall be of standard type and shall have been approved by the Engineer.
- iii. Before installing the initial test pile, the Contractor shall finalise the pile

testing arrangement and obtain approval of the Engineer.

- iv. It is envisaged that the working piles shall be installed after the successful completion of the initial pile load test.
- v. In case the Contractor desires to install the working pile, pending successful completion of initial pile load test, he may be permitted to do so, provided he gives undertaking to the Engineer to bear all associated risks and costs involved to make up for the short falls in the pile capacity, in the event of the failure of the initial pile load tests to establish specified 'Design Ultimate Load' carrying capacity of initial test pile.
- vi. The Engineer reserves the right to reject any pile which in his opinion is defective on account of less carrying capacity, structural integrity, position, alignment, concrete quality etc. Piles that are defective shall be pulled out or left in place as judged convenient by the Engineer, without affecting the performance of adjacent piles. The Contractor shall install additional piles to substitute the defective piles, as per the directions of the Engineer, at no additional cost to the Employer. Further, the cost of additional piles and increase in the pile cap size, if any, on account of additional piles, shall be borne by the Contractor.
- vii. Each pile shall be identified with a reference number and shall be as shown in the Drawings. The convenience of installation may be considered while scheduling the sequence of piling in a group.
- viii. In a pile group, the sequence of installation of piles shall normally be from the center to the periphery of the group or from one side to the other.
- ix. Level marks shall be accurately painted on each pile immediately after its installation. Subsequently, if any pile displays any tendency to heave up due to installation of other piles or due to any other reasons, the same shall be reinstalled firmly as per the directions of the Engineer without any additional cost.
- x. The Contractor shall record all the information during installation of piles, including pile-bore observations before concreting each pile. The data sheet for recording pile data shall be as approved by the Engineer. On completion of each pile installation, pile record shall be submitted to the Engineer within two days of completion of concreting of the pile.

b) Control of Position and Alignment

Piles shall be installed as accurately vertical as possible. The permissible tolerances with respect to position and inclination/alignment are as shown below:

Tolerances

No	Item	Permissible	Figure
1	Level of top i.e. Cut-off-Level (m)	-25mm to 25mm	
2	Position of the head in plan at Cut-off-Level (d)	75mm or less	
3	Embedded depth in bearing stratum (l)	Design value or more	
4	Diameter of the pile (D)	Design value or more	
5	Variation from vertical at Cut-off-Level (v)	1.5% or less	

c) Pile Boring**i. Boring Operation:**

- i) Boring operations shall be done by rotary hydraulic feed drilling rigs with reverse mud circulation or other suitable boring methods that have been approved by the Engineer. The boring or drilling equipment shall have suitable and adequate accessories for boring or drilling through all types of strata expected at site.
- ii) The size of cutting tools shall not be less than the diameter of the pile by more than 75 mm. However, the pile bore shall be of the specified size.
- iii) The boring centre shall be aligned with the pile centre and the boring machine shall be installed so as not to move or incline. The sides of the bore-hole shall be stable throughout.
- iv) Working level shall be above the Cut-off-Level. After the initial boring of about 1.0 m, temporary guide casing of suitable length shall be lowered in the pile bore for vertical pile. The diameter of guide casing shall be such as to give the necessary finished diameter of the concrete pile. The centre line of the guide casing shall be checked before continuing further boring. Guide casing shall be minimum of 1.0 m length. Additional length of casing may be used depending on the condition of the strata, ground water level etc.
- v) The temporary guide casing (if provided) shall be withdrawn cautiously, after concreting is done up to the required level. While withdrawing the casing, concrete shall not be disturbed.

- vi) For providing permanent MS liner, Clause 709.1.4 of IRC:78 shall be complied with. Whenever stricter provision has been given in the drawings, the same shall be followed.
- vii) If boring operation becomes difficult before reaching the predetermined depth, further plan of action shall be submitted by the Contractor and approval shall be obtained from the Engineer for the same. The piles shall be founded on rock or other suitable strata as approved by the Engineer.

ii. Maintaining the bore hole:

- i) For maintaining bore hole wall while boring, a stabilizing material, according to the soil shall be used and the level of the stabilizing fluid shall be maintained at not less than 2.0 m above the ground water level or at such other level as will ensure that the fluid pressure is at all times in excess of pressures exerted by the soils and external groundwater. The stabilizing fluid shall be under constant circulation till start of concreting. The level of stabilizing fluid for all piles shall be recorded by the Contractor and reported to the Engineer, including the confirmation of the bore-hole wall shape after boring. Where temporary casings or an alternative method for maintaining stability of a boring are used, these shall be subject to the Engineer's approval.
- ii) Consistency of the stabilizing material suspension shall be controlled throughout concreting operations in order to keep the bore stabilized, as well as to prevent concrete getting mixed up with the thicker suspension of the mud.
- iii) When the boring is done by rotary drilling rigs, the verticality of Kelly bar shall always be maintained. In the soil layer such as sandy soil layer where the bore hole tends to collapse, care shall be taken to ensure the drilling bucket does not hit the hole wall. While boring in the founding soil layer, the drilling bucket shall be raised at appropriate speed to prevent loosening of the soil by suction.

iii. Stabilizing material management:

In addition to the requirements that are already stated, the following shall be considered:

- i) The stabilizing material shall be controlled so as to prevent pile-bore wall collapse and ensure the quality and shape of the concrete.
- ii) While boring, the Contractor shall periodically check the properties of the stabilizing material and control the management items (specific gravity, marsh funnel viscosity, pH, etc.) to be within the values set in the Method Statement that has been approved by the Engineer.
- iii) Stabilizing fluid shall comprise of bentonite, complying with the specifications of IS 2720, IS 2911 (Part 1/ Sec2; ANNEX D) or

otherwise approved by the Engineer, thoroughly mixed with clean fresh water along with the required Polymer like CMC, to form a suspension meeting the specification requirements as submitted to and consented by the Engineer.

- iv) The Contractor shall obtain manufacturers' certificates of the bentonite powder consigned to the Site giving properties of each consignment and shall submit them to the Engineer prior to commencing the work and whenever required.
- v) The frequency of testing stabilizing material and the method and procedure of sampling shall be proposed by the Contractor and approved by the Engineer prior to the commencement of piling work. Such control tests on the bentonite suspension as required or as approved by the Engineer shall be carried out during the piling work.
- vi) Prior to concreting a pile, the Contractor shall take measures to remove any heavily contaminated stabilizing material which could impair the free flow of concrete from the tremie pipe. Placing of concrete shall proceed only with due modification as per consent of the Engineer.
- vii) All reasonable steps shall be taken to prevent the spillage of bentonite suspension in the Site in areas outside the immediate vicinity of boring.

iv. Confirmation of bearing stratum for termination level:

- i) Confirmation of the support layer shall be carried out by boring depth and comparing excavated soil and soil survey material. Also, the pile designated as per approved Method Statement or by the Engineer shall receive necessary confirmation.
- ii) The boring depth shall be measured at two or more places to the bottom of the hole immediately after completion of boring operations. The results shall be reported promptly.
- iii) A protocol shall be maintained regarding the strata at the founding level, Standard Penetration Test (SPT) value, percent core recovery, Unconfined Compressive Strength (UCS) from the nearest borehole, socketing horizon, flushing of pile bore, time interval between end of boring and start of concreting, bentonite density prior to the commencement of concreting.

v. Cleaning of pile bore just after boring:

- i) After completion of the pile bore up to the required depth, the pile bore shall be cleaned of loose, disturbed or re-moulded soil from the base of the pile.

- ii) The cleaning shall preferably be achieved by three stages flushing of slurry using airlift technique, as per approved Method Statement. The bottom of the pile bore shall be thoroughly cleaned by airlift technique. Cleaning shall ensure that the pile bore is completely free of sludge or bored material, debris of rock or boulder etc. Necessary checks shall be made to ensure the thorough cleaning of the pile bore.
- iii) Concreting operations shall not proceed if the contaminated stabilizing material at the bottom of the pile bore possesses a density of more than 1.12 g/ml. The stabilizing material sample shall be collected from the bottom of pile bore. For this a solid cone shall be lowered by a string to the bottom of pile bore. A sampler tube closed at top with a central hole (hollow cylinder) is lowered over the cone, then a top cover shall be lowered over the cylinder. Care shall be taken for proper fittings of assembly to minimise the leakage, while lifting the cone assembly to the ground surface. The slurry collected in the sampler tube shall be tested for density and sand content.
- iv) When the boring is done by rotary drilling rigs, cleaning-bucket attached to the Kelly shall be used for cleaning the bore. Wherever stabilizing material is used, after using the cleaning-bucket, the bore shall be flushed with fresh slurry.
- v) The Contractor shall measure the final depth after this cleaning and confirm its effect by comparing with the depth at the end of boring.

vi. Cleaning of pile bore just before concreting:

- i) Pile bore shall be cleaned by fresh stabilizing material through tremie pipe or as specified in the Method Statement, before (in case delay in concreting after the completion of bore) and after placing the reinforcement cage and just before the start of concreting. Pile boring shall be inspected and approved by the Engineer, in accordance with approved Method Statement, before concreting.
- ii) The Contractor shall measure the final depth after this cleaning, when there is a delay in concreting after completion of the bore, for knowing the casting pile length, and confirm its effect by comparing with the depth at the end of boring.

vii. Other relevant considerations for pile boring:

- i) Care shall be taken not to harm a recently concreted pile due to driving the casing nearby before the concrete has sufficiently set in that pile. The danger of doing harm is greater in compact soils than in loose soils.
- ii) For bored holes, the finishing and cleaning of the bore, lowering of reinforcement cage and concreting of the pile for full height must be accomplished in one continuous operation without any stoppage.

- iii) Pumping from a boring shall not be permitted unless approval has been issued by the Engineer.
- iv) A pile excavation shall be backfilled without delay where a rapid loss of drilling fluid occurs and no further excavation at the location of that pile shall be carried out until the Engineer's approval is obtained.
- v) After each pile has been cast, any empty bore which may remain shall be protected and carefully backfilled as soon as possible to the satisfaction of the Engineer.
- vi) Carriage and Disposal: The bored spoil material and contaminated mud and bentonite slurry shall be disposed at the designated areas identified by the Contractor and as per the procedure approved by the Engineer and as mandated by other relevant Contract provisions.

d) Concreting

- i. Cast-in-Situ pile concreting shall conform to provisions of **Annexure OCS-1** of these Specifications and the relevant provisions of IS 2911 (Part 1/ Sec 2), where not in contravention to the following provisions.
- ii. Concreting shall not be done until the Engineer is satisfied that the termination level of pile, is as per the installation criteria and the Method Statement that has been approved by the Engineer.
- iii. Concrete in the pile shall be coherent, rich in cement with high slump and restricted water cement ratio. The slump of concrete shall vary between 150 mm to 180 mm for bored piles. For long or large diameter piles, use of retarding plasticiser in concrete is desirable.
- iv. The time interval between the completion of boring and placement of concrete in pile bore shall not exceed 6 hours. In case the time interval exceeds 6 hours, the pile bore shall be abandoned. However, the Engineer may allow concreting provided the Contractor extends the pile bore by 0.5 m beyond the termination level and clean the pile bore. The entire cost of all operation and materials for this extra length shall be borne by the Contractor.
- v. The concrete shall be properly graded, self-compacting and shall not get mixed with soil, excess water, or other extraneous matter. Special care shall be taken in silty clays and other soils which have the tendency to squeeze into the newly deposited concrete and cause necking. Adequate head of green concrete shall be maintained to prevent inflow of soil or water into the concrete.
- vi. Concreting shall be done by tremie method. The operation of tremie concreting shall be governed by IS 2911 (Part 1/ Sec 2). Stabilizing material shall be maintained sufficiently above the ground water level, as specified elsewhere in this Specifications.
- vii. Concreting by tremie shall continue to allow the initial pours of concrete,

- mixed with stabilizing fluid, sludge and cut spoils from the bore to overflow and the consistency and quality of the overflowing concrete is comparable to that of design mix. The length of overflow shall be decided by the Engineer.
- viii. It shall be ensured that the volume of concrete poured is at least equal to the theoretically computed volume of the pile shaft being cast.
 - ix. The tremie shall have uniform and smooth cross-section inside. The tremie shall be water-tight throughout its length and have a hopper attached at its head by a water-tight connection. All tremie tubes shall be scrupulously cleaned before and after use.
 - x. While concreting the tremie shall be withdrawn slowly ensuring adequate height of concrete outside the tremie pipe at all stages of withdrawal.
 - xi. An adequate quantity of concrete within the pipe shall be maintained at all times to ensure that the pressure from it exceeds that from the water or drilling fluid.
 - xii. The tremie pipe shall be lowered to the bottom of the bore-hole, allowing water or stabilizing material to rise inside it before pouring concrete. The tip of the tremie pipe shall not be separated from the bottom of the hole more than necessary (when plunger is used, it is about 0.2 m or less from the hole bottom)
 - xiii. The tremie pipe shall always be kept full of concrete and shall penetrate well into the concrete in the borehole, at least 2 m or more, with adequate margin of safety against accidental withdrawal if the pipe is surged to discharge the concrete.
 - xiv. During concreting, the cycle time of concreting, concreting volume, concrete placement height and the height of the tremie pipe tip in concrete shall be checked for all the piles and reported in a format that has been approved by the Engineer.
 - xv. To prevent the reinforcement cage from floating during placement of concrete, appropriate countermeasures shall be made in advance, as per the Method Statement that has been approved by the Engineer. The same shall be monitored for all piles and reported.
 - xvi. Temporary casings, when used, shall be extracted carefully to the satisfaction of the Engineer, whilst the concrete is sufficiently workable to ensure it is not disturbed or lifted, and the reinforcement cage does not get disturbed. During extraction, sufficient quantity of concrete shall be maintained inside the casing to overcome the pressure from external water, soil or stabilizing material and to ensure that no reduction in section by way of necking or shearing of concrete and contamination of the pile takes place.
 - xvii. Segregation of the ingredients shall be prevented. The displacement or distortion of reinforcement during concreting shall be avoided. If the concrete is placed inside precast concrete tubes or consists of precast sections, subject

to the approval of the Engineer, these shall be free of cracks or other damage before being installed.

- xviii. While concreting uncased piles, voids in concrete shall be avoided and adequate head of concrete shall be maintained to prevent inflow of soil or water into the concrete. It is also necessary to take precautions during concreting to minimise the softening of the soil by excess water. Uncased cast- in-situ piles shall not be allowed where mudflow conditions exist.
- xix. Where concrete is placed in dry borings, measures, subject to approval of the Engineer, shall be taken to avoid segregation and bleeding and to ensure that the concrete at the bottom of the pile is not deficient in grout.
- xx. Where enlarged bases are required, as per site conditions and as approved by the Engineer, these shall be mechanically formed and shall be concentric with the pile shaft within a tolerance of 10% of the shaft diameter and shall not be smaller than the required dimension. The sloping surface of the frustum forming the enlargement shall make an angle of not less than 55° to the horizontal.
- xxi. Grouting at base of pile shall be done wherever the results of proof coring (in case of rock), sonic logging and/or loading test etc. confirm that there is a void/ sludge at the pile base. The grouting shall be done with cement slurry under suitable pressure after concrete in the pile attains the desired strength, if required by the Engineer. For this purpose, conduit pipes with easily removable plugs at the bottom end shall be placed in the bore along with reinforcement cage before concreting

14.7.4 Top of Concrete in Pile, Cut-off-Level (COL):

- a) Cut-off-Level of piles shall be as indicated in the drawings.
- b) The top of concrete in pile cast shall be above the Cut-off-Level by 1.0 m (minimum) and as per the Method Statement, to remove all laitance and weak concrete and to ensure good concrete at Cut-off-Level, for the proper embedment into the pile cap. Any exceptions, due to contingent situation, will be subject to the approval of the Engineer.
- c) Preparation of pile head: The area surrounding the piles shall be excavated up to the bottom of the pile caps. After seven days of concreting of pile, the exposed part of concrete above the COL shall be removed or chipped off and made rough at COL. In case a part of extra-pile concrete before curing is handled, the Contractor shall obtain prior approval from the Engineer. The projected reinforcement above COL shall be properly cleaned and bent carefully, only where required, to the required shape and level to be anchored into the pile cap as per the drawing. While finishing the pile head, care shall be taken to ensure no harmful damage, such as cracks, occurs in the concrete. The pile top shall be embedded into the pile cap by 150 mm as per the Drawings and as agreed by the Engineer. All loose material on the top of pile head after chipping to the desired level shall be removed and disposed as per contractual procedure and as directed by the Engineer.

14.7.5 Reinforcement Steel

- a) Reinforcement steel, along with its inspection and testing shall conform to Annexure – OCS-2 of these Specifications, along with IS 2911 (Part 1/ Sec 2) and used as per the drawings.
- b) The reinforcement shall be assembled before placing in the moulds and all hoops and links shall be of uniform length firmly wired into position. Ends of helical reinforcement, if used, shall be firmly secured. Diagonal fork spacers shall be of a pattern that has been approved by the Engineer.
- c) Lap joints in main longitudinal bars will be permitted only when, in the opinion of the Engineer, each bar cannot be supplied in one complete length. Where permitted, joints shall be provided at agreed centres, designed to develop the full strength of the bar across the joint, provided with adequate links or stirrups and staggered in position from those of adjacent longitudinal bars or as indicated in the drawings, subject to the approval of the Engineer.
- d) The 'L' bends in the reinforcements at the bottom of the piles shall not be provided to avoid the formation of soft toe.
- e) Jointing of Reinforcement Steel for Piles: Only lap joints shall be provided as shown in the drawings.
- f) Lowering of the reinforcement cage:
 - i. The reinforcement cage shall be properly aligned with the pile core and kept vertical without collapsing the hole wall. In lowering of the reinforcement cage, it shall avoid deformations, damages, etc. by using reinforcing material as necessary. In the lap joint part of the reinforcement cage, the upper and lower cages shall be in a straight line, with the joints tightly bound.
 - ii. Proper cover to reinforcement and central placement of the reinforcement cage in the pile bore shall be ensured by use of suitable concrete spacers or rollers cast specifically for the purpose, as directed by the Engineer. The longitudinal reinforcement shall project above Cut-off-Level as indicated in the drawings.
 - iii. After lowering of the reinforcement cage, the height of the top end of the reinforcement shall be measured and reported. The axes of the reinforcement cage and the pile core shall be matched, checked and reported.

14.7.6 Breaking off of Piles

If any pile already cast requires breaking due to subsequent change of Cut-off-Level, then the same shall be carried out, not before seven days of casting without affecting the quality of existing pile, such as loosening, cracking etc., and to the satisfaction of the Engineer.

14.7.7 Pile Caps

The ground shall be excavated, levelled, prepared and then layers of coarse aggregate and blinding concrete shall be constructed below pile cap. The pile cap shall then be cast as per the Drawings and conforming to Annexure OCS-1 and Annexure OCS-2 of these Specifications, subject to tolerances mentioned therein.

14.7.8 Tests on Piles**a) General**

When preparing for conducting a pile test, the Contractor shall follow the requirements of the various acts, orders, regulations and other statutory instruments that are applicable to the work for the provision and maintenance of safe working conditions, and shall in addition make such other provision as may be necessary to safeguard against any hazards that are involved in the testing or preparations for testing.

b) Load Test on Piles

- i. These Specifications covers the requirements for initial vertical load and routine vertical load tests on reinforced concrete single vertical piles of specified diameter to assess their vertical load carrying capacities. All pile load testing shall conform IS 2911 (Part 1/ Sec 4)
- ii. Full details of the equipment proposed to be used, the test setup and pile testing scheme along with detailed design, drawings shall be submitted to the Engineer, before making arrangements to carry out the tests, for obtaining his approval. Approval of the Engineer shall also be obtained after the test setup is complete, prior to commencement of loading.
- iii. The work shall include mobilization of all necessary equipment, kentledge, anchor piles and rock anchors, or combination of kentledge and anchor piles and rock anchors, providing necessary engineering supervision and technical personnel, skilled and unskilled labour as required, to carry out the complete pile testing and submission of test reports.
- iv. In all cases, the Contractor shall ensure that when the hydraulic jack and load measuring device are mounted on the pile head the whole system will be stable up to the maximum load to be applied.
- v. Necessary means shall be provided to enable dial gauges to be read from a position clear of the kentledge stack or test frame in conditions where failure in any part of the system due to overloading, buckling, loss of hydraulic pressure and so on might constitute a hazard to personnel.
- vi. The hydraulic jack, pump, hoses, pipes, couplings and other apparatus to be operated under hydraulic pressure shall be capable of withstanding a test pressure of one and a half times the maximum working pressure without leaking.
- vii. The maximum test load or test pressure expressed as a reading on the gauge

in use shall be displayed and all operators shall be made aware of this limit.

- viii. Where kentledge is used, the Contractor shall construct the foundations for the kentledge and any cribwork, beams or other supporting structures in such a manner that there will not be differential settlement, bending or deflection of an amount that constitutes a hazard to safety or impairs the efficiency of the operation. The kentledge shall be adequately bonded, tied or otherwise held together to prevent it falling apart, or becoming unstable because of deflection of the supports. The weight of kentledge shall be greater than the maximum test load and if the weight is estimated from the density and volume of the constituent materials, an adequate factor of safety against error shall be allowed.
- ix. It is essential that all the equipment and instruments are properly calibrated both at the commencement and immediately after the completion of tests, so that they represent true values. If the Engineer desires, the Contractor at his own cost shall arrange for calibration of the instruments in presence of the Engineer, at a laboratory having Engineer's approval, and the test report and calibration certificate shall be submitted to the Engineer.
- x. The complete jacking system including the hydraulic jack, hydraulic pump and pressure gauge shall be calibrated as single unit. The complete unit shall be calibrated over its complete range of travel for increasing and decreasing loads same as that of test loads. The calibration certificate shall be submitted to the Engineer.
- xi. The reaction load to be made available for the test shall be at least 25% greater than the maximum jacking force. The reaction system as relevant shall be designed for the total reaction load. All reaction loads shall be stable and balanced during all operations of testing. During testing, stability of reaction system shall be ensured.
- xii. The vertical displacement of pile shall be measured using dial gauges having a least count of 0.01 mm.
- xiii. Load test shall be conducted at pile Cut-off-Level (COL). If the water table is above the COL, the test pit shall be kept dry throughout the test period by suitable dewatering methods.
- xiv. In case of initial vertical load test, where the water table level is higher than the COL, the Contractor may use anchor piles and rock anchors for testing purposes. The Engineer, at his discretion, may decide to raise the COL above water table.
- xv. All operations in connection with pile load test shall be carried out in a safe manner to prevent exposure of the people to hazard and also to ensure the safety of manpower and material.
- xvi. Test record and report for pile load tests shall be as per IS 2911 (Part 1/ Sec 2) and as approved by the Engineer. The reports shall be submitted to the

Engineer immediately on completion of each test.

- xvii. Two fixed independent benchmarks shall be established as reference points at least 15 m from the test pile to monitor the settlements.
- xviii. If any initial pile load test gets abandoned and is not successfully completed, then the Contractor shall install another test pile and repeat the initial test after correcting the fault, at his own cost.
- xix. On completion of a test all equipment and measuring devices shall be dismantled, checked and either stored so that they are available for use in further tests or removed from the Site.

c) Test Pile Installation

- i. Piles shall be installed as per Sub-Clause 3.5.3 herein above.
- ii. Pile installation data as applicable shall be furnished along with the load test results to the Engineer.

d) Types of Tests

- i. Initial vertical (compression) load test and lateral load test shall be carried out on test piles, which are not to be incorporated in the work, to assess the 'Ultimate Load Capacity of Pile' before the commencement of the installation of working piles.
- ii. The test piles shall have the same design details as of the working piles typically adopted in the predominant soil profile in that area.
- iii. Routine vertical (compression) load test and lateral load test shall be conducted to verify the load carrying capacity of working pile.
- iv. Pile integrity test shall be carried out on each pile by The Low Strain Method as per IS 14893 to verify the structural integrity, shape and continuity of pile

e) Number of Tests:

- i. **Initial pile-load tests:** The number of load tests shall be as per IS 2911 (Part 4) depending upon the total number of piles but not less than two (2). Wherever the soil strata are erratic or there is change in structure type (such as river bridge, rigid frame), additional tests shall be required as directed by the Engineer.
- ii. **Routine pile-load tests:** The number of tests may generally be 0.5 percent of the total number of piles required, but not less than one (1). The number may be increased up to 2% depending upon the nature, type of structure and sub-strata condition.
- iii. Initial and routine tests may be suitably increased for important structures or cases with large variation in the subsurface strata as directed by the Engineer.
- iv. Pile load tests shall be carried as per IS 2911 (Part 4).

f) Testing-Piles

- i. The testing-piles for routine load test shall be identified by the Engineer. For initial load test, testing-pile shall be installed as a test-pile, separate from working piles, as directed by the Engineer.
- ii. A minimum time period of four weeks shall be allowed between the time of pile casting and testing. Testing-pile head shall be prepared for testing purposes only, one week after casting the pile.
- iii. Testing-piles shall be cut off at the proper level and provided with a proper cap, to provide a plane bearing surface for the test plate and for proper arrangements for seating of the jack and dial gauges.

g) Static Vertical Load Test

- i. The tests shall conform to IS 2911 (Part 4).
- ii. Equipment and Test Setup
 - i) A steel plate of adequate thickness and not less than 50 mm shall be centered on the pile cap to prevent it from getting crushed under applied load. The size of the circular test plate shall not be less than the pile size nor less than the area covered by the base of the hydraulic jack(s).
 - ii) The datum bars shall be supported on immovable supports, preferably of concrete pedestals or steel sections, placed sufficiently far away from the test pile. The distance shall not be less than 3 times the diameter of testing-pile and in no case less than 2 metres from the edge of testing-pile. These supports shall be placed at an adequate depth below ground to be unaffected by ground movements.
- iii. Loading System

The test load on pile shall be applied by means of hydraulic jack(s) which obtain reaction in one of the ways mentioned in Cl.7.1.3 of IS 2911 (Part 4).

The measurement of strains for load monitoring may also be done by load cell connected to a digital read out unit.
- iv. Test Procedure
 - i) Application of Load:- The test should be carried out by applying a series of vertical downward incremental load each increment being of about 20 percent of safe load on the pile. For testing of raker piles it is essential that loading is along the axis.
 - ii) This is applicable for both initial and routine test. In this method application of increment of test load and taking of measurement or displacement in each stage of loading is maintained till rate of movement of the pile top is not more than 0.2mm/h or until 2 h has

elapsed, whichever is earlier subject to a minimum of 1 h. The test load shall be maintained for 24 h.

- iii) Duration of vertical loading shall be as per Cl. 7.2 of IS 2911 (Part 4)
- iv) Settlement:- Settlement shall be recorded as per Cl. 7.1.4 of IS 2911 (Part 4).
- v) The safe vertical load on single pile for the initial test shall be as per Cl. 7.1.5 of IS 2911 (Part 4).
- vi) Items to be measured:

The following items shall be measured:

- Time;
- Applied pressure;
- Applied load;
- Displacement at the pile head;
- Movement of reaction devices;
- Others, as decided by the Engineer.

- vii) Commencement, interruption and completion of the test:
 - The test shall be commenced after ensuring the conditions surrounding the site, preparations of all equipment and the suitability of the weather condition.
 - If any abnormal conditions are noticed during the test, the test shall be interrupted promptly. The test can only be resumed when the cause of the abnormal condition has been detected and rectified.
 - The test shall be completed when the objectives of the test shall have been achieved, or when it is judged that abnormal conditions make it impossible to continue the test.
- viii) Loading on the pile shall be continued till as given in IS 2911 (Part 4).

h) Lateral load tests – Lateral load tests shall be carried out on test pile as well as on working pile safe load capacity determined as per Clause 8 of IS 2911 (Part 4).

i) Pile Integrity Test on Working Piles (other than piles subjected to routine load test):

- i. Pile integrity test shall be carried out on each pile by The Low Strain Method as per IS 14893:2001. In case of large diameter piles, the tests shall be conducted at 5-6 places to cover the entire section of the pile.

- ii. The tests shall be conducted on piles whose length is correctly recorded or on test piles where available, to determine the value of stress wave velocity and characteristic or reference signal for comparing the signals for testing subsequent piles.
- iii. The area surrounding the pile should be free from standing water and kept dewatered during the tests. The pile head should be accessible.
- iv. Testing should be free of work likely to cause disturbance. The cast-in-situ piles should not be tested normally before 14 days of casting.
- v. The test piles, if available at site, can be used to determine the pulse velocity and characteristic or reference signal generated. Where no test pile is available information can be obtained from cast piles whose length is accurately recorded.
- vi. Methodology for Low Strain Integrity test:
 - i) This is a system of assessing the integrity of piles by the use of low stress wave imparted to the pile shaft and is also known as Sonic Integrity or Sonic Echo Test. A small metal/hard rubber hammer is used to produce a light tap on top of the pile. The shock traveling down the length of the pile is reflected back from the toe of the pile and recorded through a suitable transducer/accelerometre (also held on top of the pile close to the point of impact) in a computer disk or diskette for subsequent analysis. The primary shock wave which travels down the length of the shaft is reflected from the toe by the change in density between the concrete and sub-strata. However, if the pile has any imperfections or discontinuities within its length these will set up secondary reflections which will be added to the return signal.
 - ii) The reflected stress wave can be monitored using either processing technique, the observed signals are amplified and converted into digital display as velocity versus length or frequency versus mobility records, providing information on structural integrity of piles. The stress wave velocity and approximate pile lengths are provided as input for the integrity testing. The stress wave velocity is dependent on the Young's modulus and mass density of pile concrete. This value generally lies between 3000-4000 metre per second depending on the grade of concrete used (M15-M25).

j) Sampling, Testing, Inspection, and Acceptance Criteria Including Construction Tolerances of Piles

- i. Frequency of sampling, testing and quality assurance including the method of conducting the tests, acceptance criteria and construction tolerances shall be as mentioned herein above and included in the Method Statement that has been approved by the Engineer. The tests shall be performed and reported as per the Method Statement that has been approved by the Engineer.

- ii. Forcible corrections for any deviations shall not be made to concrete piles.
- iii. Data Reporting and processing
 - i) The assessment of structural integrity is based on two equally important aspects:
 - Quality of signals, and
 - Accurate analysis and interpretation of signal.
 - ii) Piles requiring remedial measures should be so marked immediately on completion of the field integrity testing and rectification measures selected.
 - iii) The final report should include signals of each integrity test and structural condition of piles.
- iv. Submission of Results: Immediately after testing, a signed copy of all the raw data of a pile shall be given to the Engineer. A test report shall be submitted to the Engineer within 3 days after testing.

14.7.9 Safety

The Contractor shall adopt appropriate method and practice conforming to IS 5121 (Piling and other deep foundation - Code of Safety) suiting to local ground characteristics.

14.8 Formwork

Form work for bridge foundations, sub structure and superstructures shall be as per IS-3696, IS-4014 and Annexure OCS-1. It includes all temporary or permanent forms required for forming the concrete of the shape, dimensions and surface finish as shown on the drawing or as directed by the Engineer, together with all props, staging, centering, scaffolding and temporary construction required for their support.

14.9 Substructure

14.9.1 Piers and Abutments

- a) Concrete and reinforcement for piers and abutments shall conform to relevant sections of these specifications and drawings. In case of concrete piers, minimum grade will be M 20 unless otherwise specified / approved. The number of horizontal construction joints shall be kept to a minimum. Construction joints shall be avoided in splash zones unless specifically permitted by the Engineer and provided they are treated in accordance with special provisions. No vertical construction joint shall be provided. Shear connectors in the form of vertical plumbs, dowels, bond bars or rail cut pieces shall be provided at all horizontal joints as directed by Engineer. The work shall conform strictly to the drawings or as directed by the Engineer.
- b) In case of tall piers and abutments, use of slipform shall be preferred. The design, erection and raising of slip form shall be subject to special specifications which will be furnished by the Contractor. The concrete shall also be of higher grade and subject to additional specifications as necessary. All specifications and arrangements shall be subject to the approval of the Engineer.

- c) The surface of foundation / well cap / pile cap shall be scraped with wire brush and all loose materials removed. In case reinforcing bars projecting from foundations are coated with cement slurry, the same shall be removed by tapping, hammering or wire brushing. Care shall be taken to remove all loose materials around reinforcements. Just before commencing masonry or concrete work, the surface shall be thoroughly wetted.
- d) In case of solid (non-spill through type) abutments, weep holes as shown on the drawings or as directed by the Engineer, shall be provided.
- e) The surface finish shall be smooth, except the earth face of abutments which shall be rough finished or left as form finished.
- f) In case of abutments likely to experience considerable movement on account of backfill of approaches and settlement of foundations, the construction of the abutment shall be followed by filling up of embankment in layers simultaneously with filter backing behind to the full height to allow for the anticipated movement during construction period before casting of superstructure.
- g) *Transitional system on approach road bridges as per guidelines of RDSO Report No. GE: R-50 shall be provided in bridge approaches of ballasted and non ballasted deck bridges having span equal to or more than 12.2m.*

14.9.2 Pier Cap and Abutment Cap (Bed Blocks)

- a) Form work, Concrete and reinforcement shall conform to relevant paras of Concrete work & RCC of these specifications and the Drawings. Unless otherwise specified, minimum grade of concrete mix shall be M 35.
- b) The locations and levels of pier cap / abutment cap / pedestals and bolts for fixing bearings shall be checked carefully to ensure alignment in accordance with the drawings of the bridge.
- c) The surface of cap shall be finished smooth and shall have a slope for draining of water as shown on the drawings or as directed by the Engineer. For short span slab bridges with continuous support on pier caps, the surface shall be cast horizontal. The top surface of the pedestal on which bearings are to be placed shall also be cast horizontal.
- d) The surface on which elastomeric bearings are to be placed shall be wood float finished to a level plane which shall not vary more than 1.5mm from straight edge placed in any direction across the area. The surface on which other bearings (steel bearings, pot bearings) are to be placed shall be cast about 25mm below the bottom level of bearings and as indicated on the drawings. Specified rich levelling mortar shall be provided over this at the time of placing of bearing.

14.9.3 Dirt / Ballast Wall, Return Wall and Wing wall

- a) Dirt / ballast walls ,return wall & wing walls shall be in RCC. Minimum grade of concrete will be M35 unless otherwise specified. In case of cantilever return walls,

no construction joint shall generally be permitted. Wherever feasible, the concreting in cantilever return walls shall be carried out in continuation of the ballast wall.

- b) For concrete return and wing wall, the surface of foundation shall be prepared in the same manner as prescribed for construction of abutment. No horizontal construction joint shall be provided. If shown on drawing or directed by the Engineer, vertical construction joint may be provided. Vertical expansion gap of 20mm shall be provided in return wall / wing wall at every 10 metre intervals or as directed by the Engineer. Weep holes shall be provided as prescribed for abutments or as shown on the drawings.
- c) Form work, reinforcement and concrete in dirt / ballast wall shall conform to relevant sections of these specifications.
- d) The finish of the surface on the earth side shall be rough/form finish while the front face shall be smooth finished.
- e) Architectural coping for wing wall / return wall in brick masonry shall conform to Drawings.

14.9.4 Tests and Standards of Acceptance

The materials shall be tested in accordance with these specifications and shall meet the prescribed criteria.

The work shall conform to these specifications and shall meet the prescribed standards of acceptance.

14.9.5 Tolerances in Concrete elements

- a) Variation in cross-sectional dimensions: + 10mm, -5mm
- b) Misplacement from specified position in plan: + 10mm
- c) Variation of levels at the top: + 10mm
- d) Variations of reduced levels of bearing areas: + 5mm
- e) Variations from plumb over full height: + 10mm
- f) Surface irregularities measured with 3m straight edge
 - i) All surfaces except bearing areas: 5mm
 - ii) Bearing areas: 3 mm

14.9.6 For construction of Br Nos. 150 and 153 temporary diversion of existing roads will be required first. Then existing roads will be lowered by about 1.90 m at the site of the bridges and regraded to join the existing roads. Thereafter Br Nos. 150 and 153 will be constructed.

14.9.7 Well Foundation

Well Foundation shall be constructed as per IRS Bridge Substructure & Foundation Code/ IRC: 78, IRS-CBC, Manual on the design and construction of well foundation.

14.10 Bridge Work : Superstructure

14.10.1 GENERAL

a) Coverage

This chapter covers specifications for the following types of superstructures:

- i. RCC Box
- ii. Prestressed concrete girders and slabs
- iii. Steel- Open Web Girders (OWG) and Composite Girders

14.10.2 RCC BOX

All concrete works for RCC box shall conform to **Annexures OCS-1 & 2**.

14.10.3 STEEL Open Web Girders (OWG) and Composite Girders

Fabrication and erection of steel girders shall conform to **Annexure OCS-3**.

Concrete and reinforcement for composite girders shall conform to **Annexures OCS-1 & 2**.

14.10.4 PRE-STRESSED CONCRETE GIRDERS AND SLABS

All prestressed works for bridges shall be carried out in accordance with **Annexures OCS-1 to 4**. PSC slabs of 12.2 m span shall be cast on a prepared casting bed and shall thereafter be launched in position after prestressing using suitable capacity crane.

Chapter 15**BALLASTLESS TRACK****15.1 GENERAL**

- a) BLT in tunnel has to be laid over the tunnel invert concrete base.
- b) Electrical Interface: The plinth electrical continuity is essential, for which purpose the Contractor shall supply and install suitable connection.
- c) The opposite electrical continuity between rail bases shall be checked by means of a low resistance continuity apparatus (10V-100 amp) in presence of the Engineer.
- d) Detailed specification for RCC to be used *in construction* shall be as per *Annexure OCS-1 & Annexure OCS-2*

15.2 BALLASTLESS TRACK INSTALLATION**15.2.1 GENERAL**

- i. The track gauge throughout shall be 1673 mm (nominal) measured between the running edge gauge point of each rail and normal to the Centre line of the track 14 mm below top of rail.
- ii. All main line track shall be laid with 1:20 inward rail slope.

15.2.2 RAIL JOINTING

- i. All rail joints throughout the main lines glued insulated joints, switch expansion joints etc. shall be welded.
- ii. The welding of nominal rail lengths into long welded rail panels for main lines shall be done with Mobile Flash butt welding machine approved by RDSO. Wherever the Mobile Flash Butt welding is practically not possible the Alumino-thermit welding can be done in accordance with RDSO specification.

15.2.3 RAIL EXPANSION JOINTS

- i. Particular attention shall be given to ensure that rail expansion joints are assembled and installed in accordance with the Drawings and correctly located with relation to the type of Rail Expansion joint and the direction of traffic.
- ii. Immediately prior to completion of a section, all sliding surfaces of rail expansion joint shall be cleaned and greased.

15.2.4 RAIL TEMPERATURE

Rail temperatures shall be measured using appropriate dial type magnetic thermometers placed on the web of the rail on the shaded side. A minimum number of thermometers required to be used per rail for measuring average rail temperature of a segment of track shall have the prior approval of Engineer.

15.2.5 CLEANING OF TRACK

The track from structure (including the rail surface) as installed shall be thoroughly cleaned to an acceptable standard as approval by the Engineer immediately after

installation and as required thereafter maintaining the standard until the arrangement of service trails so as to provide adequate levels of electric insulation and rail surface quality for correct performance of train control and signaling equipment under prevailing climate and environment conditions.

15.2.6 RAIL INSULATION

The track as installed shall be thoroughly cleaned immediately after insulation. This shall be necessary to provide adequate levels of electrical insulation for the correct performance of the signaling and traction equipment under the prevailing climatic and environment condition.

15.2.7 CUTTING OF RAILS

- i. Rails shall only be cut by using abrasive rail cutting machines. The proposed method and equipment for the cutting of rails shall have the prior approval of the Engineer.
- ii. Rails required to be cut shall be cold sawn square and vertical across the rail. A deviation from square or vertical of more than 0.5mm measured about the rail head, shall not be permitted. All burrs shall be removed from the rail ends.
- iii. Quality of cutting shall be such as to ensure tolerances *specified* in Alumino-thermit welding manual.

15.2.8 STAGES OF REQUEST FOR INSPECTION DURING CONSTRUCTION OF SLAB TRACK.

A. The ballastless track system consists of:

- i. Support structure done as a part of tunnel civil works
- ii. Reinforced concrete slab track
- iii. Rail fastening system (design and drawing shall be submitted by the bidder/contractor for approval).

“Request for inspection” shall be submitted to the Engineer, Complete with all necessary information to allow assessment, after the following activities and approval must be received prior to the commencement of any follow-on activity.

- a) Acceptance of support structure including specified surface treatment
- b) Acceptance of the slab track reinforcement
- c) Acceptance of temporary/false works shuttering, jigs, fixtures and supporting arrangements
- d) Acceptance of the track for concreting
- e) Acceptance of the track for the movement of construction of plant equipments and machinery
- f) Acceptance of the track for in-situ welding
- g) Acceptance of the track for distressing

- B.** *All third party (RDSO/RITES/Any other nominated agency) inspection charges, if any, for Ballastless Track system shall be paid by the Employer.*

15.2.9 REINFORCED CONCRETE SLAB TRACK

- a) The ballastless tracks shall be laid with reinforced concrete slab track on supporting structures.
- b) The ballastless track shall be constructed by Top down method of construction. The laying tolerance for various parameters for the installed Ballastless track shall be strictly achieved in accordance with the relevant clauses in these specifications. For achieving these tolerances the tenderer may propose the method/scheme of construction of ballastless track along with the tender submission. However, the sole responsibility of achieving the stipulated track laying tolerances lies with the Contractor.
- c) The Contractor shall be responsible to calculate the height of the slab track at each location to maintain the desired rail level as shown in the relevant drawings and submit the same for the approval of the Engineer. The reinforced concrete slab track shall be laid on the tunnel invert duly making the provision for cant and vertical curves.
- d) Suitable construction joints shall be provided for the slab track in tunnel. Location of the joints shall be in conformity with the location of other joints in the tunnel structure.
- e) The handling and transport arrangement of rails shall ensure no damage to the rails.
- f) Resilient pads placed under the metal base plates shall be coated with silicon or any suitable product, on their underside and lateral side, to stop them adhering to the slab track concrete, as approved by Engineer.
- g) During the concreting phase, the track fastening device, the running rails and the expansion joints templates shall be protected by movable covers against possible splattering of concrete.
- h) Conduits required for crossing of signaling wires shall be have to be provided before concreting as directed by the Engineer.
- i) Immediately after concreting of slab track the assembly consisting of the rails and the plinth segments shall be covered by wet cloths to prevent damage due to rise in temperature.
- j) These cloths shall be damped constantly for 8 hours from the time of pouring the concrete.
- k) The rail fastening between the metal base plates and running rails base shall then be removed to authorize differential movement in the longitudinal direction between the rails and structures.
- l) Twenty-four (24) hours after pouring of the slab track concrete, the formwork shall be removed.

- m) The concreted surfaces of the slab track below the base plates shall be smooth, devoid of any inclusions, roughness cracks and without showing any aggregate at the surface.
- n) Temporary rails shall not be used for constructions, slab track shall be constructed using the permanent rail to be finally fastened.

15.3 TEST FOR RAIL FASTENING SYSTEM COMPONENTS

The following tests are required to be conducted for fastening system-

- a) Pull out strength test of anchor bolts.
- b) Longitudinal creep resistance test of rail seat assembly.
- c) Fatigue test of tension clamp.
- d) Fatigue test of helical spring.
- e) Stiffness test (static & dynamic) of elastic base plate pad & the ratio of dynamic to static stiffness at various frequencies.
- f) Fatigue tests of assembly as a whole. These tests shall cover as minimum heat generated in pads in terms of temperature, records of gauge, rotation of rail head, slippage of rail foot, and lateral & vertical movement of base plate and vertical deflection of rail head.
- g) Installation procedure tests.

15.4 RAIL INSULATION TO EARTH TEST

- a) All track work shall be subjected to a rail insulation to earth test. The track shall have a minimum rail to earth value of 40 Ω /km of single track for ballastless tracks.
- b) The rail to earth test shall be undertaken after the track has been completed and cleaned but before it is finally formed into a continuously welded system and before all the bonding is installed.
- c) Junctions shall be isolated and tested prior to their final connection into the track.
- d) The test shall be undertaken on rail lengths up to maximum lengths of 1000 m. The tracks shall not be finally formed into a continuous length, nor shall the junctions be joined to the adjacent tracks, until the rail insulation to earth tests have been undertaken and approved.

15.5 BALLASTLESS TRACK BASE RESISTANCE TESTS

- a) A ballastless track base resistance test shall be undertaken on all track lengths over 50 meters as a check of the leakage of current through the track base and rail fastening system from one rail to the other.
- b) The ballastless track base resistance test shall be undertaken after the track has been complete and cleaned but before it is finally formed into a continuous length and all the bonds are attached.
- c) The testing procedure and the minimum resistance shall comply with the

requirements proposed by the engineer.

15.6 RAIL INCLINATION INSPECTION

- a) Both rails of all ballastless running line tracks shall be checked, at maximum 10m intervals, for inclination using an approved equipment/method in the presence of the engineer.
- b) Should any reading show the inclination to be outside the specification limits every alternate fastening assembly shall be further checked either side of the non-compliant reading until compliant readings are consistently obtained.

15.7 RAIL WELDING:

- a) The main line track shall be welded into LWR/CWR using mobile flash butt welding machine approved by RDSO. Wherever the mobile flash butt welding is practically not possible the Alumino-thermit SKV process welding shall be done with the approval of the Engineer through agencies approved by RDSO and as per provision of manual for fusion welding of rails by the Alumino-thermit process supply of portion must be and procurement is from sources approved by RDSO.
- b) Welding shall be supervised by trained welding supervisor and carried out by trained welder having competency certificate from RDSO/Lucknow in his possession.
- c) The preparation of rail ends to be ensured before welding.
- d) The Contractor shall arrange for test welds and their testing done as per manual.
- e) The welds shall be finished to final profile by grinding and the finished weld shall be within the specified tolerance.
- f) Each joint shall have distinctive marks as per details in the manual.
- g) Weld collar shall be painted against corrosion as per specification given in manual.
- h) All the recorded welds shall meet the acceptance tests including ultra-sonic test.
- i) Rail joints welded by the Contractor shall be guaranteed against failure for a period of 2 years from date of welding the joints in track or from date such welded joints made in cess are inserted in the track. Any such welded joint which fails within guarantee, the joints shall be rewelded free of cost.
- j) In case of failure of sample test joint, the period of guarantee for 100 joints represented by the sample joint shall be extended for a further period of 1 year. In case of failure of joints exhibiting sign of failure by cracking within extended period of guarantee, the joints shall be rewelded free of cost.
- k) When one bad joint is required to be replaced by two new joints, the entire cost of both the joints shall be borne by the Contractor.
- l) Drilling of holes in the 60kg rails is strictly not permitted.

15.8 DESTRESSING OF CWR:

- a) Destressing must be done as per provisions of Indian Railway Permanent Way

Manual.

- b) Destressing of rails shall not be undertaken until it has been demonstrated to Engineer's satisfaction that the track has been completed to the specified standard specifications and the method of working for destressing of the relevant track has been approved by the Engineer.
- c) Destressing must be done in accordance with temperature conditions stated in the Railway Manual.
- d) The stress free temperature condition of LWR shall be achieved naturally or artificially by the use of hydraulic rail tensors as approved by the Engineer.

15.9 CONSTRUCTION PROCESS

Tenderers are advised to visit local sites location as specified in tender to get familiar with typical local environment like drainage system/extent of tunnel and water flooding during monsoon period in tunnel area etc.

Procedure of construction process of BLT should be mentioned in details suitable to local site conditions including necessary ground improvement. Removal of earth to required level followed by filling of coarse grained material in layer along with COMPACTION by vibratory process & system offered should be easy in construction suitable to condition prevailing on specified tunnel section in tender, clearly demonstrating how it can be constructed & installed within a reasonable time frame.

15.10 MAINTENANCE AND PERFORMANCE MONITORING

- a) The *Defects Notification Period (DNP)* will be for 3 years from the date opening of traffic.
- b) After Construction of Ballastless track, HRIDC will monitor the performance jointly with the Contractor on quarterly basis & for 3 years. The performance monitoring will be based broadly upon following parameters:
- c) Efficacy of fastening: Fastening system should be able to maintain track geometry (gauge, cross level, loose fitting etc.) at all times within track tolerances during service without any components breakage, excessive wear & tear.
- d) Track tolerances to be maintained at the time of construction & during trial/services should be as per Section VII-5 Outline Design Specification (ODS) - Civil.
- e) Any track settlement which impairs the functionality of ballastless track.
- f) Any visible crack of width more than 0.1 mm in concrete/RCC portion of slab which impairs the functionality of ballastless track.
- g) Efficacy of drainage system e.g. the slope and drains constructed should function properly during Monsoon period.
- h) Any special observation.
- i) The decision of HRIDC about performance of the ballastless track after monitoring period shall be final.

Chapter 16

OPEN EXCAVATION

16.1. SCOPE OF WORK

- 16.1.1. The specifications described herein under relate to the work of open excavation for various structures and shall include all labour, tools, plants, Constructional Plant and services, necessary to carry out the excavation of different type of materials, geological mapping of excavated surfaces, dewatering, temporary slope stabilization measures required to facilitate excavation, transportation and stockpiling / disposal of all excavated materials into stockpiles / dumping areas as shown on the drawings or as approved by the Engineer.
- 16.1.2. Excavation shall be made to the lines, grades and dimensions shown on the drawings or as otherwise directed by the Engineer, which shall be required to be backfilled with acceptable material and compacted by contractor in a manner acceptable to the engineer.
- 16.1.3. The Contractor shall maintain the excavated slopes, drainage and trenches and prepare foundations as shown in the drawings or as required by the Engineer. The Contractor must ensure slope protection measures for riverbank and non- dumping station areas ensuring environmental mitigation measures as per the approved environmental mitigation plan.
- 16.1.4. The area of open excavation shall, where, in the opinion of the Engineer, clearing is necessary, be cleared of all trees, bushes, rubbish and other objectionable matter and the materials so removed, shall be disposed off suitably or as directed by the Engineer
- 16.1.5. When additional excavation outside the lines and grades shown on the drawings is required by the Contractor for his own convenience, such additional excavation shall be required to be backfilled with acceptable material and compacted by the Contractor in a manner satisfactory to the Engineer. The Contractor shall submit his plans for such proposed work in writing for the Engineer's acceptance prior to the commencement of the work.
- 16.1.6. The removal of mud and slush resulting from heavy rains or flooding of the sites, when necessary to ensure the safe and effective performance of the work shall be performed by the Contractor. For this purpose, Perimetric drains will also be required to be provided at a suitable distance from the edge of the cutting around the slopes to ensure the safe drainage of superficial water, avoiding slope erosion.
- 16.1.7. At all times during construction, the Contractor shall adopt such excavation procedures that at no time the stability of any slope be impaired. For the excavation in intake area special care shall be exercised and the Contractor shall adopt modern controlled blasting techniques.
- 16.1.8. The approval given by the Engineer to the Contractor's methods and equipment shall not relieve the Contractor of his full responsibility for a proper and safe execution of excavation, or of liability for injuries to, or death of person(s), or any obligations under this Contract.

16.1.9. The Contractor shall comply with all safety procedures and requirements as stipulated elsewhere in the Tender Documents.

16.2. SUBMITTALS

16.2.1. At least 4 (four) weeks prior to the commencement of excavation, the Contractor shall submit details of his excavation methods and sequences for all open excavation Works including the schedule of deploying equipment.

16.2.2. The description of drilling and blasting procedures shall include the following:

- i. Diameter, burden, spacing, depth, pattern and orientation of blast holes
- ii. Type, strength, amount (kg of explosive/hole) and distribution of explosives to be used, per hole.
- iii. Description and purpose of any special method to be adopted by the Contractor.
- iv. Sequence of various activities of the excavation work with an indication of corresponding time requirements.

16.2.3. At least 4 (Four) weeks prior to dumping or stockpiling of any excavated material, the Contractor shall submit the layout of the spoil and stockpile area. All data pertinent to working methods and provisions for the security, stability and temporary and permanent drainage of the work areas shall be included along with details of volumes, material types, heights and grade provided. To prevent spillage of muck, R. R. masonry/ Gabion retaining walls with adequate arrangement shall be provided in disposal area.

16.2.4. To enable the Engineer to verify all necessary setting out and elevations carried out by the Contractor, the latter shall notify the Engineer in writing, giving at least 1(one) week notice of his intention to start excavation.

16.2.5. The Engineer reserves the right to require any additional information deemed necessary to be included in the submitted documents

16.3. CLASSIFICATION OF EXCAVATION

16.3.1. Open excavation shall comprise of the following types of excavation:

16.3.2. Soil excluding Rock (Seismic velocity $V_p < 1000$ m/s)

- i. Loose excavation shall include all types of soil and such other material, which can be excavated manually by ordinary pick and shovel or barring and wedging or by mechanical equipment such as dozer blade, Ripper, power shovel and dragline but without resorting to blasting. It shall also include embedded boulder not bigger than 1-meter size in anyone direction. The Contractor will endeavor to provide proper excavation method in such so as not to over excavate the soil beyond the final design line. It will be necessary to provide the details of competence level of the shovel operator to excavate such areas as per the design.

16.3.3. Rock not requiring blasting (Seismic velocity > 1200 m/s to 2000 m/s).

- i. This shall include excavation of all rock, which can be excavated by mechanical equipment such as dozer blade, Ripper, power shovel and dragline but without resorting to blasting to loosen the same. The Contractor will endeavor to provide proper excavation method in such so as not to over excavate the soil beyond the final design line. It will be necessary to provide the details of competence level of the shovel operator to excavate such areas as per the design.
- ii. This shall also include boulders and detached rock blocks of size larger than one meter in any direction. It shall also include the removal of softer materials lying between layers of rock.

16.3.4. Hard Rock requiring controlled blasting (Seismic velocity >2000 m/s)

- i. This shall include excavation of all rock, which cannot be excavated without prior blasting to loosen the same.
- ii. The term rock shall include boulders and detached rock blocks of size larger than one meter in any direction which requires blasting for removal. It shall also include the removal of softer materials lying between layers of rock.

16.3.5. Hard Rock requiring blasting but blasting not permitted

- i. This shall include excavation of all hard rock, which cannot be excavated without blasting but due to restriction imposed at site by employer, the same is required to be excavated by chiseling or Rock breaker, vibratory rock rippers, and rotary drum cutters. Alternatively, propellants (non-detonating silent explosives e.g. NONEX, ROYAX or plasma blasting).

Table 1. Comparison of various non-explosive blasting characteristics

Types	Economy	Application scope	advantage	Disadvantages	
Mechanical broken	Hydraulic splitting machine	normal	Mines, precious stones and so on	Safe, weak vibration, environmental protection	Mechanical wear, low efficiency
	Hydraulic breaker	normal	Municipal engineering, mountain, ice, demolition and so on	Safe, environmentally friendly	Mechanical wear, medium hard rock should not be used
	Boring machine	Higher	Coal mines, tunnels and so on	Safety, environmental protection, into Lane efficient and good quality	Mechanical wear, complex structure, maintenance difficulties
Physical Chemistry acting	Static expansion agent	low	Quarries, concrete and so on	No fly stone, no vibration, environmental protection	Lithology and climate impact, low efficiency,
	Carbon dioxide cracker	low	Quarries, coal mines, concrete and so on	High safety, small vibration	Lack of standardization, there is a certain security risk.
	Metal burners	Higher	Precious stone mining	No throwing, no toxic gas	Waste metal, lively metal prone to danger
Electrical Equipment	Plasma blasting	normal	Dismantling Municipal engineering	High safety, small vibration, no throwing	Equipment requirements are high, broken rock volume is small
	Heat splitting rock	normal	Auxiliary rock breaking	Hard rock effect is significant	Only applies to auxiliary rock breaking

Ref: <https://iopscience.iop.org/article/10.1088/1757-899X/322/2/022014/pdf>

- ii. The term rock shall include boulders and detached rock blocks of size larger than one meter in any direction which requires blasting for removal. It shall

also include the removal of softer materials lying between layers of rock.

16.3.6. Removal of Slip

Unavoidable slips, which may occur in the excavated slopes, shall be removed by loading, hauling, dumping of the material and the surface cleaned.

16.3.7. Dental Excavation

- i. Dental excavation shall include the removal of unsuitable material from shear zones, clay seams, pockets, joints, or from spaces between boulders beyond the lines of excavation shown on the Construction Drawings or established in the field, which are too small to be excavated by common earth moving equipment.
- ii. Dental excavation, depending on its extent will require the use of a backhoe, hand tools, or other small excavating equipment, as well as the use of a high velocity air-water jet. The methods employed shall be such as to avoid fracturing of the rock adjacent to the material being removed.
- iii. Dental excavation shall be performed where directed. The extent, to which such material shall be removed, including the depth, direction, and dimensions of the work, will be determined by the Engineer. Such excavation shall be backfilled with concrete or shotcrete. No blasting will be permitted.

16.4. REMOVING BLUFFS AND LOOSE ROCK

16.4.1. All loose boulders, semi-detached rocks (along with the earthy stuff which might move therewith) not directly in excavation but so close to the area to be excavated as to be liable in the opinion of the Engineer, to fall or otherwise endanger the workmen, equipment of the Work, shall be stripped and removed from the areas of excavation. The methods used shall be such as not to shatter or render unstable or unsafe any rock that was originally sound and safe. Any material not requiring removal as contemplated in the Work but which, in the opinion of the Engineer is likely to become loosened or unstable later on shall also be promptly and satisfactorily removed as directed by the Engineer.

16.5. EXCAVATION IN OPEN CUTS

16.5.1. The side slopes of the excavation shall be as shown on the drawings or as directed by the Engineer.

16.5.2. Any changes in the slopes as shown on the drawings on account of site conditions shall be subject to the approval of the Engineer.

16.5.3. Every precaution shall be taken to prevent slips. In case slips occur, the slipped material shall be removed to the designed / modified slope.

16.5.4. Suitable berms shall be left at appropriate places with necessary approach, ramps and sump pits for installation of dewatering pumps or other purpose, as required by the Engineer. This may warrant use of line drilling along the final line of excavation. Excavation should be conducted in a manner to expose half holes of such line drilled holes. All excavation shall be carried out finished to lines and grades shown on the drawings and to the satisfaction of the Engineer.

- 16.5.5. In case of loose excavation where the surface is left as excavated or is to be covered by pitching formation of rain cuts and gullies shall be avoided by proper drainages. Any gullies formed shall be "made good" by properly packing excavated rock spoil in them. All holes left by removing boulders shall also be filled in with rock spoil and stabilized.
- 16.5.6. Where plain surfaces are required, such faces of excavation shall be formed in such a manner that would least shatter the rock mass. Only light blasting or ream holes or similar methods shall be allowed in areas adjacent to such faces.
- 16.5.7. In special locations (only in rock) where specifically indicated or ordered by the Engineer, the use of explosives shall be discarded and excavation completed by the drilling, wedging or barring or other suitable method approved by the Engineer.
- 16.5.8. All excavations, done beyond the lines and dimensions shown on the drawings, which are to be covered by concrete shall be filled back with the concrete of the same grade and quality or as directed by the Engineer.
- 16.5.9. Blasting within 30 m of concrete works or grouted area shall be permitted preferably after concrete or grout is 7 days old and only after the submission by the Contractor and approval by the Engineer of a plan showing the relative positions of structures or grouted area and the areas to be blasted, Contractor's proposed drilling and blasting plan together with an outline of precautions to be taken.
- 16.5.10. All concrete works and other completed works within 30m of blasting shall be protected by limiting the charges / size of blasts to ensure that the maximum displacement velocity of particles at nearby structures is not more than 50 mm per second. For concrete or grout less than seven days old, this velocity shall not be more than 10 mm per second.
- 16.5.11. No blasting shall be permitted within 15 m radius of concrete works or grouted area.
- 16.5.12. The open cut excavation shall be done by benching with individual bench height not exceeding 2 m.
- 16.5.13. The Contractor shall carry out the excavation of open cut rock slopes utilizing controlled blasting techniques including line drilling and presplit blasting as per relevant codal provisions.
- 16.5.14. Where depth of open rock excavation is more than 10 m, the excavation shall be carried out in a descending way, from horizontal berms, by benching.
- 16.5.15. Immediately after excavation and scaling to the satisfaction of Engineer and prior to the excavation of next bench, the Contractor shall install rock bolts, provide wire mesh, shotcrete and temporary relief holes if considered necessary, as shown on the drawings or as required by the Engineer.
- 16.5.16. All blasted rock shall be removed from the bench toe before undertaking further work.
All other specifications pertaining to blasting and scaling etc. relevant to open excavation shall be as per stipulations of Section of Explosive and Blasting.
- 16.5.17. In all cases where blasting is to be conducted, the attenuation equation based on trials arranged by the Contractor should be used to define the maximum charge per delay to control the vibrations within the stipulated limits (as per DGMS Guidelines). The field

constants and the maximum charge per delay will be scrutinized by CSIR-CIMFR and approved by the engineer and practiced in all such cases by the Contractor.

- 16.5.18. In case of blasting being conducted near a dam, CSIR-CIMFR will conduct the blast trails, work out the attenuation equation and hence maximum charge per delay and continuously monitor the ground vibration at few places on the dam as per requirements. Contractor will have to adhere to the recommendations of CSIR-CIMFR and engineer.

16.6. EXCAVATION FOR FOUNDATIONS OF STRUCTURE

- 16.6.1. While carrying out excavation for the foundations of the structure, if it is considered necessary for a Work and if approved by the Engineer, the sides of the loose excavation shall be shored and strutted to the satisfaction of the Engineer.
- 16.6.2. After completion of the loose excavation, the rock excavation in foundations of the Structures shall be carried out to the depths as shown on the drawings. At all stages of excavation, precautions shall be taken to preserve the rock beyond the lines of required excavation. The quantity and strength of explosives used in the foundation excavation in rock in various locations shall be such as will neither damage nor crack the rock outside the limits of excavations.
- 16.6.3. As the excavation approaches its final lines and is within 300 mm to 600 mm of the specified foundation levels, the depth of the holes and the strength and quantity of explosives shall be progressively and suitably reduced so as to ensure that the rock profile beyond the lines and levels specified on the drawings shall remain undisturbed. If so, directed by the Engineer, this excavation shall be carried out by the line drilling.
- 16.6.4. Final excavated surface shall have no abrupt changes in slope and sharp projection greater than 500 mm. Projections in excess of 500 mm shall be treated where necessary by supplementary excavation as determined by the Engineer to produce the desired surface of contact between concrete and rock.
- 16.6.5. All excavations done beyond the lines and the dimensions shown on the drawings shall be back filled with concrete of the same grade and quality as that of the foundation or as directed by the Engineer.
- 16.6.6. Acceptance criteria for important foundations: Important structures shall be founded on sound and competent rock and suitable for taking up the load of the super structure without undergoing deformation beyond the acceptable limits as per the directions of Engineer. After excavation up to fresh rock level, further excavation shall be done up to one meter by wedging and barring to remove all the loose and soft, weathered rock, sheared material etc. All sheared portion shall be excavated to a desired depth and filled with concrete with steel reinforcements as per approved design and drawings. Concreting shall be taken up only after getting written approval of the Engineer.
- 16.6.7. Stable slopes shall be provided in open excavations along with berms of specified width as per approved design & drawings.
- 16.6.8. All permanent rock slopes shall be stabilized by suitable treatments such as shotcrete

with chain link mesh, rock anchors, spot rock bolts, perforated drainage pipes, berms with drains etc., as per approved design and drawings. The width of the berms shall not be less than 4 m. The slope to be provided in various types of rock as per weathering condition shall depend upon slope stability calculations and as per design drawings & IRPWM. If not available in design drawings & IRPWM it shall be as below.

- | | |
|-------------------------------|-------------------------------------|
| i. Fresh rock | 0.20-0.25 (H): 1 (V). |
| ii. Moderately weathered rock | 0.33-0.50 (H): 1 (V). |
| iii. Highly weathered rock | 0.67-1.00 (H): 1 (V). |
| iv. Overburden | 1.25 (H): 1 (V) to 1.50 (H): 1 (V). |

16.6.9. The cut slopes in overburden shall be treated with dry rock stone masonry with horizontal and vertical bunds of course rubble masonry in cement mortar 1:4 of 1 meter width as per approved design & drawings.

16.6.10. Surface Preparation of Foundations

- i. After completion of excavation of foundations, trimming for the final removal of all dummy rock or loosened mass, shall be done by chiseling, barring and wedging as directed by the Engineer.
- ii. Any weathered or decomposed rock remaining shall be removed. Open fissures joints; crevices and any other doubtful areas shall be cleaned to a suitable depth up to firm rock and backfill with the concrete/mortar of the same grade as that of the main structure and contact grouting as specified.
- iii. Consolidation grouting of the foundation rock shall be carried out upto the specified depth before the placement of concrete.
- iv. Contractor shall wash all rock surfaces of the excavations. This washing shall be carried out initially for inspections when required by the Engineer.
- v. Final washing of any section of the work prior to concreting or application of shotcrete shall be carried out only when the blasting for the excavation and removal of projections inside the neat lines has been completed.
- vi. Final washing prior to concreting shall be done by directing a stream of water at a pressure of about 8 to 10 bars on the rock surfaces from a distance of 1.5 meter through a nozzle of 18 mm diameter so as to remove all loose rock, fragments, dust and debris from the surfaces.

16.7. DISPOSAL OF EXCAVATED MATERIALS

16.7.1. All the excavated material shall be the property of the Contractor. The Contractor has to make his own arrangements for land required for dumping areas outside of HORC limit (at sufficient distance as per relevant provisions) for disposal of excavated materials. The technical specifications for developing and rehabilitating the muck disposal sites shall be as submitted by contractor and agreed by the Engineer.

16.7.2. The Contractor shall make necessary arrangements for the management of muck disposal so that it meets all the environment guidelines / conditions imposed for the

construction of project by MoEF&CC / Govt. bodies / State Pollution control board and/or other statutory bodies.

- 16.7.3. Surfaces of material so disposed off shall be trimmed to regular lines and grades satisfactory to the Engineer. Disposal of all material shall be such that it will not interfere with natural drainage and is as per the regulations for environmental protection or with Engineer's acceptance. The Contractor must ensure muck management as per the approved environmental mitigation plan with proper turfing and plantation at dumping sites. Nothing extra shall be paid for it.
- 16.7.4. The Contractor shall ensure that no excavated materials are disposed off in the streams or at locations where these are liable to be washed away by the floods or may block the water way of streams.
- 16.7.5. The plan of muck dump yard fill, berms and provision of retaining walls, slope of fill etc. will be as per site requirements and the same shall be got approved by the Contractor from ENGINEER before start of such works.

16.8. DRAINAGE

- 16.8.1. Seepage water from springs or rainwater shall be suitably collected and drained away from work area by gravity, wherever it is possible to do so. Where, however, drainage by gravity is not feasible, pumping could be resorted to all stipulations laid down in Section of "Dewatering, Drainage, Pumping and Dewatering" shall be followed.

16.9. BACKFILL

- 16.9.1. Backfill shall consist of materials as approved by the ENGINEER and shall be placed in locations as directed by the ENGINEER.
- 16.9.2. Only suitable materials obtained from excavation, if practicable, shall be used for backfilling.
- 16.9.3. Material to be used in backfill shall be free drainage type.

16.10. CUT & COVER TUNNEL

- 16.10.1. *Construction of Cut & Cover tunnel shall be done as per Annexure OCS-1 and Annexure OCS-2. Before taking up actual construction, the Contractor shall construct a 2 m long mock up, Cut & Cover tunnel section including drainage, waterproofing etc. completed at a location approved by the Engineer.*

16.11. MEASUREMENT AND PAYMENTS

16.11.1. General

- i. This is a lump sum contract hence no separate payment will be made for any of the items separately. Tenderer shall consider all expenditures in their total offered cost. However, all detailed measurement shall be recorded for all the works executed for the purpose of quality check, preparation of completion/

as built drawings and future operation & maintenance.

- ii. The Contractor is assumed to have included the entire scope but not limited to the following:
 - A. Provision of all labour, equipment and materials required for open excavation in various locations including drilling holes for blasting, developing and improving controlled blasting methods, performance of blasting, cleaning, washing protection and maintaining excavated surfaces in satisfactory conditions' and additional excavations if any, required by the Contractor for his construction methods.
 - B. Geological mapping of the excavated area and the temporary stabilization measures adopted for facilitating the open excavation work.
 - C. Provision for loading, handling and dumping the excavated material on stockpiles, contractor's dumping area outside railway limit, shaping and trimming of the excavated materials in the dumping area, cleaning of the stockpile area, formation and maintenance of stockpiles, rehandling of suitable materials including segregating; grading, draining and drying of materials suitable for use in embankment construction or as backfill.
 - D. Deleted.
 - E. Deleted.
 - F. Complying with all requirements of statutory laws and regulations relating to the works and any restrictions resulting from obtaining all necessary permits and licenses for the purchase, use storage and transport of explosives and other materials.
 - G. Surveying, setting out, checking of excavated profile, layouts and any subsequent rectification works resulting from unable or incorrect surveys, provision of suitable equipment for and delays due to carrying out this work.
 - H. Furnishing, installation, operation, maintenance and removal of Communication and illumination systems and observing safety precautions.
 - I. Recording and preparation of reports related to excavation progress and procedures.
 - J. All work involved with and any partial or short interruptions or inconveniences caused by the check surveys, performance of the rock mechanics tests, installation and monitoring of instruments and geological mapping, for which no separate payment is provided elsewhere in these specifications.

Seepage water or rainwater suitably collected and drained away by gravity including provision of catch drains, diversion of nallah etc.

- K. Dewatering by pumping in the open excavation area due to any reason whatsoever.
- L. The compensation for removal of mud and slush resulting from heavy rains/flooding of the sites, if necessary, to ensure the safe and effective performance of the work shall be deemed to be included in the overall quoted amount for complete work in this contract.
- M. The payment towards the preparation of disposal area shall 'be deemed to be included in the overall quoted amount for complete work in this contract”.
- N. Excavation for drainage trenches will not be paid separately.
- O. All taxes duties.
- P. Clearing of all trees, bushes, rubbish and any other objectionable materials and their removal and disposal.
- Q. Over excavation beyond the excavation lines shown on the drawings, removal of material or backfilling with acceptable material where and when as required by the Engineer.
- R. Replacement of survey points fixed by the Engineer, which are damaged by Contractor's negligence, and fixing of additional survey points near working area.
- S. Methods adopted for specially controlled excavation at foundation level or near the faces where plain surfaces are required.
- T. Formation of berms or ramps sump pits for installation of dewatering pumps at places, which fall beyond the specified excavation lines.
- U. Replacement or repair of concrete or other works damaged by blasting.
- V. Over-excavation required for contractor's convenience. The concrete required to fill such excavation shall also be at the Contractor's expense.
- W. Draining, shaping and trimming of the dumped materials in waste disposal area to the lines and grades as directed or approved by the Engineer.
- X. Provision of catch drain, nallah diversions etc. to avoid flow of water to working area.

16.11.2. Open Excavation

- i. This is a lump sum contract hence no separate payment will be made for any of items separately. Bidders shall consider all expenditures in their total offered cost. However, all detailed measurements shall be recorded for all the works executed for the purpose of quality check, Preparation of completion/ as built drawings and future operation & maintenance.

Measurement of excavation will be of the in-situ volume defined by the excavation lines as shown on the drawings, and shall be worked out on the basis of solid volume, worked out from the initial, intermediate, and final ground cross sections recorded or as per direction by the Engineer.

- ii. Cross sections will be taken normal to the center line at as close intervals as practicable but, in any case, not more than 5 meters and 3 meters apart in loose excavation and rock respectively, prior to the starting of excavation in each class of material, unless some other method is acceptable to the Engineer in any particular location of the work.
- iii. This includes entire cost of
 - A. Drilling holes for blasting
 - B. Developing and improving controlled blasting methods
 - C. Blasting tests, explosives and performance of blasting
- iv. Payment for removal of bluffs and loose rock close to the areas to be excavated shall be deemed to have been included in the overall quoted amount for complete work in this contract.
- v. Payment for removal of *all avoidable and* unavoidable slips, which may occur in the excavated slopes, will be deemed to have been included in the overall quoted amount for complete work in this contract.

16.11.3. Shoring and Strutting

The rates for shoring and strutting shall be included in the overall quoted amount for complete work in this contract.

16.11.4. Dental Excavation:

If measurement by volume proves impracticable, the surface area of seams and cracks to be cleaned may be equated, as the conditions dictate, to a volume mutually agreed upon by the Contractor and the Engineer.

16.11.5. Royalties.

Soil or rock spoils such as stones, boulder, pebbles, gravels etc. available from excavation, if are found suitable for use in works as per required specifications, can be used free of cost but the legally payable royalty and taxes are to be paid by contractor to the concerned authorities. Necessary proofs to be submitted by contractor in this regard.

Annexure OCS-1**PLAIN AND REINFORCED CEMENT CONCRETE****1 MATERIALS**

- a) Before bringing to the site, all materials for concrete shall be approved by the Engineer. All approved samples shall be deposited in the office of the Engineer before placing orders for the materials with suppliers. The materials brought on to the works shall conform in every respect to their approved samples.
- b) Fresh samples shall be deposited with Engineer whenever type or source of any material changes. The Contractor shall check fresh consignment of materials as it is brought on to the works to ensure that they conform to the specifications and/or approved samples.
- c) The Engineer shall have the option to have any of the materials tested to find whether they are in accordance with specifications at the Contractor's expense. All bills vouchers and test certificates which in the opinion of the Engineer are necessary to convince him as to the quality of materials or their suitability shall be produced for his inspection when required.
- d) If fly ash is used in concrete, the Contractor shall demonstrate the quality control procedure including source of fly ash, its properties, handling as per the relevant IS & international codes etc. and shall use in slabs and walls only after “no objection” to the same has been obtained from the Engineer.
- e) Any materials which have not been found to conform to the specifications and not approved by the Engineer shall be rejected forthwith and shall be removed from the site by the Contractor at his own cost within the time stipulated by the Engineer. The Engineer shall have the powers to cause the Contractors to purchase and use materials from any particular source, as may in his opinion be necessary for the proper execution of work.
- f) Contractor shall also ensure that all constituents of exposed concrete shall be taken from same sources to achieve a uniform colour and texture.
- g) Approved list of Manufacturer's/Suppliers is given in Section VII- 8:Tender Drawings and Documents. In case the Contractor desired to procure the material from any other supplier, it shall be got approved by the Engineer.

2 Cement**2.1 Product and Materials for Cement**

- a) Cement to be used in the works shall conform to 53-grade OPC (IS 269:2015) or blended cement such as Portland Pozzolana Cement (IS 1489:2015) or Portland Slag Cement (IS 455:2015).
- b) The Contractor shall submit to the Engineer the Manufacturer's Certificate to affirm that the cement complies with the relevant standards.

- c) Samples of the proposed cement shall be taken and forwarded to an independent laboratory for analysis before the source is approved.
- d) Prior to ordering cement, the Contractor shall submit details of the proposed supplier or manufacturer and information on the proposed methods of transport, storage and certification for the Engineer's approval and show that the quantity and quality required can be attained and maintained throughout the construction period. In exposed concrete elements, the cement used in the concrete for entire element shall preferably be from a single manufacturer to ensure uniform colour.
- e) Subsequent to obtaining the Engineer's approval, the Contractor shall not change the agreed arrangements without the prior approval from the Engineer. Each delivery of cement shall be accompanied by a certificate which shall be submitted to the Engineer immediately after the delivery showing the place of manufacture and the results of standard tests carried out by the manufacturer.

2.2 Testing for Cement

- a) Samples shall be tested from every batch of cement delivered on site or once for every 1000 bags whichever is more frequent. The sampling from bulker shall be increased as decided by the Engineer.
- b) Samples shall be taken immediately on receipt of cement at site. The methods and procedures for sampling shall be in accordance with IS: 3535.
- c) Tests shall be carried out as per IS4031 for physical analysis as fineness, initial and final setting time and compressive strength and results approved by the Engineer before use. The Contractor shall provide complete facilities at site for carrying out the following tests:
 - i. Setting time by vicat's apparatus as per IS:5513 and IS:4031.
 - ii. Compressive strength of cement as per IS: 4031, IS:650, IS:10080.
- d) The Engineer may require any other form of sampling and tests including chemical analysis. Total chloride content in cement and total sulphur content calculated shall in no case exceed the requirements of Table 2 of IS 269. In case the cement supplied is of doubtful quality, tests shall be done in accordance with IS 4032. The costs of such additional tests shall be borne by the Contractor.

3 Aggregates

3.1 General

Aggregates shall conform to the provisions specified in IS 383:2016. The Contractor shall submit to the Engineer certificates of grading and compliance for all consignments of aggregate. In addition, at site from time to time, the Contractor shall allow for carrying out tests and for supplying test records to the Engineer. Prior to commencing any concrete work, the Contractor shall obtain the Engineer's approval of the proposed types and sources of aggregate.

For fair faced concrete, the Contractor shall ensure that aggregates are free from iron pyrites and impurities, which may cause discoloration. Aggregates shall be stored on paved areas in different compartments according to their nominal size.

Sampling of aggregates shall be as per IS 2430.

3.2 Fine Aggregates (Sand)

- a) The grading of the sand shall conform to IS:2386(Part1). The grading of fine aggregate shall be within the grading zones I, II, III. Sand, if found too coarse, shall be suitably blended with finer sand obtained from approved sources to obtain the desired grading. The provision of two types of sand, their separate stacking and their mixing in the specified proportions shall be at the Contractor's own cost.
- b) The sand shall not contain silt, shale, clay and other weak particles for more than a total of 3% by weight. In case of sand containing excess silt, clay and chlorides, the sand shall be washed in screw type mechanical washers in potable water to remove the same. The screening and washing of sand shall be completed at least one day before using it in concrete. The washed sand shall be stored on a sloping platform while ensuring that contamination is avoided.
- c) Water absorption shall be less than 3% by weight (ASTM C 117)
- d) The sand shall be screened on a 4.75 mm size screen to eliminate oversized particles. The Contractor shall carry out the following tests at Site and ensure that the appropriate provisions of Indian or other standards, as may be applicable, are complied with:
 - i. Proportion of clay, silt and fine dust by sedimentation method as per IS 383:2016 and IS 2386 (Part II)
 - ii. Moisture content in fine aggregate as per IS 2386(Part III)
 - iii. Water absorption shall be worked out as per IS 2386(Part III)
 - iv. Bulk Density or bulkage as per IS 2386(Part III)
 - v. Grading of fine aggregate as per IS 383:2016 and IS 2386(Part I)

3.3 Coarse Aggregates

- a) All coarse aggregate shall conform to IS: 383 and tests for conformity shall be carried out as per IS: 2386, Parts I to VIII.
- b) The maximum size of coarse aggregate shall be such that the concrete can be placed without difficulty so as to surround all reinforcement thoroughly and fill the corners of formwork. The grading of coarse aggregate shall be such that not more than 5% shall be larger than the maximum size and not more than 10% shall be smaller than the smallest size. Between these sizes the coarse aggregate shall be well graded. Unless otherwise permitted by the Engineer the nominal maximum size shall not exceed 20 mm.
- c) Water absorption shall be less than 3% by weight (ASTM C 117)
- d) Coarse aggregates used for the Works shall be crushed stone conforming to IS 383, obtained from approved sources by the Engineer. Only quarries having jaw crushers

with choke feeding arrangements producing aggregates of nearly cubical shape shall be applied.

- e) Coarse aggregate containing flat or flaky pieces or mica shall be rejected.
- f) The Contractor shall carry out the following tests at site and ensure that the appropriate provisions of following Indian standards as may be applicable are complied with:
 - i. Moisture content in coarse aggregate as per IS 2386(Part III)
 - ii. Water absorption shall be worked out as per IS 2386(Part III)
 - iii. Bulk density and voids as per IS 2386(Part III)
 - iv. Grading of coarse aggregate as per IS 383:2016 and IS 2386(Part I)

4 Water

Water used in the works shall be potable water and free from deleterious materials. Water used for mixing and curing concrete as well as for cooling and/or washing aggregate shall be fresh and clean free from injurious amounts of oil, salts, acids, alkali, sugar other chemicals and organic matter. Mixing and curing with seawater shall not be permitted.

Water shall be from the source approved by the Engineer and shall be in accordance with IRS: CBC(Cl.4.3), IS: 456 (Cl. 5.4) and/or BS 3148.

Water samples from the intended source of supply shall be taken for analysis before any concrete work commences, and at regular intervals throughout the duration of the Works, as approved by the Engineer. Whenever the source of water changes, the water shall be tested for its chemical and other properties or impurities to ascertain its suitability for use in concrete, subject to the approval of the Engineer. No water shall be used until tested and found satisfactory. Cost of all such tests shall be borne by the Contractor.

5 Chloride Content

The chloride content of aggregates shall be within the recommended limits stated in IS: 383 or BS 882 and the chloride content of the concrete mix shall be within the recommended limit of IS: 456 or BS 8110. Chloride levels shall be determined daily in accordance with the methods described in BS 812.

6 Alkali-Silica Reactivity

If aggregates contain any materials which are reactive with alkalis in any of the constituents of the concrete, or in water which will be in contact with the finished work, then the Contractor shall take samples of these materials every week. The Contractor shall ensure that the concrete mix complies with the requirements of this Specification regarding "Minimising risk of alkali-silica reaction in concrete". The results of the Contractor's weekly monitoring tests shall be submitted in writing to the Engineer-in-charge.

7 Sulphate Content

The total acid soluble sulphate content of the concrete mix, expressed as SO₃, shall not exceed the recommended limit in IS: 456 or BS 8110.

8 Reinforcement Steel

The Contractor shall refer to **Annexure - C** of these Technical Specifications.

9 Binding Wire

GI wires of 1.6mm diameter shall be used for binding of reinforcements. It shall conform to the provisions laid down in IS 280.

10 Concrete Admixtures

- a) Admixtures shall conform to the provision laid down in IRS: CBC (Cl. 4.4).
- b) Concrete admixtures are proprietary items of the manufacturer and shall be obtained only from established manufacturers with proven track record, quality assurance and full- fledged laboratory facilities for the manufacture and testing of concrete. Naphthalene or melamine-based admixtures that are approved by the Engineer only shall be used in the Works. The admixture shall be non-air entraining type. The Contractor shall provide the following information concerning each admixture after obtaining the same from the manufacturer:
 - i. Normal dosage and detrimental effects, if any, of under dosage and over dosage.
 - ii. The chemical names of the main ingredients in the admixtures.
 - iii. The chloride content, if any, expressed as a percentage by weight of the admixture.
 - iv. Values of dry material content, ash content and relative density of the admixture which can be used for uniformity tests.
 - v. Whether or not the admixture leads to the entrainment of air when used as per the manufacturer's recommended dosage, and if so, to what extent.
 - vi. Where two or more admixtures are proposed to be used in any one mix, confirmation of their compatibility.
 - vii. Whether or not there would be an increase in risk of corrosion of the reinforcement or other embodiments as a result of using the admixture.
 - viii. Retardation achieved in initial setting time.
- c) Physical and chemical requirements of admixtures shall conform to IS 9103. In addition, the following conditions shall be satisfied:
 - i. Plasticizers and superplasticizers shall meet the requirements indicated for "Water reducing Admixture".
 - ii. The air content of freshly mixed concrete, in accordance with the pressure method given in IS 1199, shall not be more than 1% higher than that of the corresponding control mix.
 - iii. There shall be no chloride content in admixture when tested in accordance with IS 6925.

- iv. Uniformity tests on the admixtures are essential to compare qualitatively the composition of different samples taken from batch to batch or from the same batch at different times.
- v. All tests relating to the concrete admixtures shall be conducted periodically at an independent laboratory and compared with the data given by the manufacturer.
- vi. While qualifying the admixture, the infrared spectrograph plot shall be given. Each batch of the supply shall be tested for IR spectrograph and prove the consistency of supply.

11 Minimising the Risk of Alkali-Silica Reaction (ASR) in Concrete

a) Precautions against ASR in Concrete

Concrete mixes for use in the Permanent Works shall comply with one of the Subsections (b), (c) or (d). The Contractor shall notify the Engineer of his proposals for complying with this requirement.

- b) The cementitious material shall have a reactive alkali content not exceeding a maximum value of 0.6% by mass when defined and tested in accordance with Subsections 3.3.1 ((e) to (k) inclusive).

To combat the ASR, Microsilica shall be used in minimum 5% cement and shall not exceed 10% by the wt of cement in order to bind free alkalis early in plastic concrete and to reduce the permeability of concrete to prevent the moisture and external alkalis penetration.

OR

- c) The total mass of reactive alkali in the concrete mix shall not exceed 3.0 kg/m³ of concrete when defined, tested and calculated in accordance with Subsections 3.3.1 ((e) to (k) inclusive) and 3.3.1 ((l) to (o) inclusive).

OR

- d) The aggregate shall be classed as non-reactive in accordance with the definition in Subsection (n).
- e) Cementitious Material (Hydraulic and Latent Hydraulic Binders):
- f) The term alkali refers to the alkali metals sodium and potassium expressed as their oxides. The reactive alkali content of Portland cements shall be defined as the percentage by mass of equivalent sodium oxide (Na₂O) calculated from:- % equivalent Na₂O = % acid soluble Na₂O + 0.658 x (% acid soluble K₂O)
- g) The method used in determining the acid soluble alkali content of the materials shall be in accordance with BS 4550: Part 2: Subsection 16.2.
- h) The Contractor shall make available the certified average acid soluble alkali content of Portland cement on a weekly basis.
- i) The Contractor shall give immediate notice of any change which may increase the certified average acid soluble alkali content above the level used in the mix design

for the concrete. A revised mix design for any concrete which would be affected by the increased alkali content shall be submitted for consent with notification of the change.

- j) Minimising the Risk by Using Cementitious material Containing less than 0.6% Reactive Alkali

The requirements of Subsection (b) will be met by Subsection (k) provided that the contribution of alkalis from other sources does not exceed 0.2 kg/m³ (see Subsections and (u)). Where alkalis exceed 0.2 kg/m³ the requirements of Subsections (l) to (o) shall apply.

- k) The cementitious material shall be Portland cement complying with Indian Standard and shall have additionally a certified maximum acid soluble alkali content not exceeding 0.6%.
- l) The Contractor shall provide on request weekly certificates which name the source of the cement and confirm compliance with the Specification.

Minimising the Risk by Limiting the Reactive Alkali content of the concrete to 3.0 kg/m³. The requirements of Subsection (c) will be met provided that Subsections (m), (n) and are satisfied.

- m) The reactive alkali content of the concrete contributed by the Portland cement to the concrete shall be calculated from:

Portland cement

$$A = \frac{C \times a}{100}$$

Where,

A = reactive alkali content of the concrete to the nearest 0.1 (kg/m³)

C = target mean Portland cement content of the concrete (kg/m³)

a = certified average acid soluble alkali content of the Portland cement (%).

- n) Where reactive alkalis in excess of 0.2kg/m³ are contributed to the concrete from sources other than the cementitious material the limit of 3.0 kg/m³ from the cementitious material shall be reduced by the total amount so contributed.

The reactive alkali contributed by sodium chloride contamination of aggregates shall be calculated from:

$$H = \frac{0.76 \times (NF \times MF) + (NC \times MC)}{100} \text{ (kg/m}^3\text{)}$$

100

Where,

H = equivalent alkali contribution made to the concrete by the sodium chloride

NF = chloride ion content of the fine aggregate as a percentage by mass of dry aggregates and measured according to BS 812: Part 4

MF = fine aggregate content (kg/m³)

NC = chloride ion content of the coarse aggregate as a percentage by mass of dry aggregate and measured according to BS 812: Part 4: 1976 (now in draft as Part 117)

MC = coarse aggregate content (kg/m³).

The factor 0.76 is obtained from a consideration of the composition of sea water.

The chloride ion content of aggregate sources containing 0.01% of chloride ion by mass or more shall be determined weekly in accordance with BS 812 or another approved method. When the chloride ion level is less than 0.01% it shall be regarded as nil.

- o) The Contractor shall provide certificates on request confirming compliance with the Specification and stating:
- i. The target mean cementitious material content of the concrete.
 - ii. The names of the works manufacturing the cement.
 - iii. A weekly report of the cement alkali determinations in accordance with Subsection (f).
 - iv. The certified average acid soluble alkali content of the Portland cement.
- p) Minimising the Risk by Using Selected Aggregates
- Fine and coarse aggregate material shall comply with the requirements of IS:383 (and/or AASHTO Standard Specifications M6 and M80 respectively) to be taken out to conform to 512(2).
- q) Water
- r) Water for use in the manufacture of concrete shall be obtained from a public utility undertaking supply or from a source approved by Engineer and shall be of potable quality, and comply with the requirement of IS:456 and or BS 3148
- s) Where a potable mains supply is not available the Contractor shall obtain confirmation of the quality and reliability of the proposed source from the appropriate water authority and shall thereafter seek consent from the Engineer to use the proposed source.
- t) Water other than from a public utility undertaking supply shall be sampled at a frequency to be determined by the Engineer and tested in accordance with the relevant provisions of IS:3025 or BS 3148. The sodium oxide and potassium oxide content shall be declared and expressed as equivalent Na₂O and shall be taken into account when calculating the total reactive alkali content of the concrete mix.
- u) Admixtures and Pigments

Admixtures and pigments shall comply with the requirements of IS 9103 and IS:6925 or BS 5075 and BS 1014. The manufacturer's declared equivalent acid soluble alkali content and the dosage rate of any admixture or pigment to be incorporated shall be included with details of all concrete mixes submitted for consent.

- v) The alkali content of admixtures shall be taken into account when determining the total equivalent alkali content of the concrete mix.
- w) Micro silica (silica fume) shall be used in 5% by the weight of cement and shall not exceed 15% by the weight of cement.

12 Storage of Materials

12.1 General

- a) Handling and storage of all material shall be as per IS 4082.
- b) All materials shall be stored at proper places to prevent their deterioration or intrusion by foreign matter and to ensure their satisfactory quality and fitness for the work. The storage space shall also permit easy inspection, removal and restoring of the materials. All such materials even though stored in approved storage places, will be subjected to acceptance test prior to their immediate use.
- c) The procedures to be adopted for transportation and storage of the materials shall obtain prior approval from the Engineer.

12.2 Cement

- a) Cement shall be transported, handled and stored on the site in such a manner as to avoid deterioration or contamination. Cement shall be stored above ground level in perfectly dry and watertight sheds and shall be stacked not more than eight bags high. Wherever bulk storage containers are used, it shall be ensured that their capacity is adequate to cater to the requirement at Site and they are cleaned at least once every 3 months. Cement older than 3 months from the date of manufacture shall not be used.
- b) Each consignment shall be stored separately so that it may be readily identified and inspected, and cement shall be used in the sequence in which it is delivered at Site. Any consignment or part of a consignment of cement which had deteriorated of any sort during storage, shall not be used in the Works and shall be removed from the Site by the Contractor, without adding any costs to the Employer.
- c) The Contractor shall prepare and maintain proper records on site regarding delivery, handling, storage and use of cement. These records shall be available for inspection by the Engineer at all times.
- d) The Contractor shall make a monthly return to the Engineer on the date corresponding to the interim certificate date, showing the quantities of cement received and issued during the month and in stock at the end of the month.

12.3 Aggregates

- a) Storage areas for aggregates have to be covered, protected against any kind of contamination, avoid the possibility of mix among aggregates and protected also against any water inflow. The floor of the storage for aggregates has to be in concrete and has to be drained. Storage areas for different size of aggregates have to be independent to avoid any possibility of mix.
- b) During rainy and cold weather periods, the aggregates shall be stored undercover for at least 48 hours before being used and kept sufficiently dry.
- c) The stockpiling of the processed aggregate and drawl there from shall be such as to ensure that the variation in the free moisture in the aggregate during anyone shift of working, does not exceed 1 percent.
- d) The coarse aggregates shall, be stored as per the procedure of relevant IS: codes.
- e) Care shall be taken in screening and stocking of the coarse aggregates so as to avoid intermixture of different gauge materials and inclusion of any foreign materials.
- f) The stockpiles shall be built up in horizontal or gently sloping layers.
- g) Trucks and bulldozers shall be kept off the stockpiles to prevent breakage and impairing the cleanliness of aggregate.
- h) A hard base shall be provided to prevent contamination from underlying materials in storage areas in continuous use.
- i) Overlap of different sizes of materials shall be prevented with suitable walls or by ample distance between storage piles.
- j) Arrangement shall be made to store natural and manufactured sand in a way that shall protect it from being contaminated with dust, organic matter or other deleterious substances.

13 Design Mix Concrete

13.1 General

- a) For all items of concrete, only design mix shall be used. Prior to the commencement of construction, the Contractor shall design the mix and submit the proportions of materials, including admixtures to be used to the Engineer for obtaining approval. Suitable water reducing admixtures or super-plasticizing admixtures shall be used for achieving desired workability and strength of the concrete only after obtaining prior approval from the Engineer. No extra payment shall be made for such admixtures.
- b) Mix design shall conform to the provisions under IRS: CBC (Cl. 5.5 and 8.7) and IS 10262.
- c) Drying shrinkage of concrete shall be 0.03% or less. Drying shrinkage of concrete shall be tested in accordance with IS 1199.
- d) When non-bleeding high flow concrete is used, it shall be confirmed that no bleeding occurs under Concrete Bleeding Test specified in IS 9103. The Contractor shall submit

the test results to the Engineer prior to the commencement of concrete works for obtaining approval.

- e) Mix design, once approved, must not be altered without obtaining prior approval of the Engineer. However, if the Contractor anticipates any change in quality and/or change in source of future supply of materials than that used for earlier mix design, the Contractor shall inform the Engineer well in advance and bring fresh samples sufficiently in advance, to carry out fresh trial mixes.
- f) The total chloride content of all constituents of concrete in mix shall be limited to 0.43 kg/m³ for reinforced concrete works and prestressed concrete works as per IS:14959.

13.2 Workability of Concrete

- a) The mix shall have the consistency which allows proper placement and consolidation in the required position. It shall be ensured that uniform consistency is maintained.
- b) Workability of concrete shall conform to the provisions of IRS: CBC(C1.5.3).

13.3 Durability of Concrete

- a) Maximum water cement ratio for design mix shall conform to IRS: CBC(Clause5.4.3) as follows:

Plain Concrete	Reinforced Concrete
0.45	0.40

- b) Minimum grade of concrete shall conform to IRS: CBC(Clause5.4.4) as follows:

Plain Concrete	Reinforced Concrete
M-20	M-35

- c) Maximum and minimum permissible cementitious material shall conform to IRS: CBCClause5.4.5) as follows:

Minimum(kg/cum)		Max
Plain Concrete	Reinforced Concrete	
250	350	500

13.4 Trial Mixes

- a) The Contractor is entirely responsible for the design of the concrete mixes. However, the design shall have approval from the Engineer. At least 8 weeks before commencing any concreting in the Works, the Contractor shall make trial mixes using samples of coarse aggregates, sand, water, super plasticiser and cement, typical of those to be used

in the Works, and which have been tested in an approved laboratory. A clean dry mixer shall be used, and the first batch shall be discarded.

- b) The mix shall be designed to produce the grade of concrete having the required workability, durability and a characteristic strength not less than appropriate value given in IRS: CBC (CL. 5.1, 5.3 & 5.4). Trial mixes shall be prepared under full-scale site conditions and tested in accordance with IS 10262.
- c) Whenever there is a significant change in the quality of any of the ingredients for concrete, the Engineer, at his discretion, may order the carrying out of fresh trial mixes. All costs for trial mixes and tests shall be borne by the Contractor's and held to be included in the rates quoted in the priced Bill of Quantities.
- d) Before commencing the Works, the Contractor shall submit full details of the preliminary trial mixes and tests to the Engineer for approval.

13.5 Size of Coarse Aggregate

The nominal size of coarse aggregates for concrete shall be as per the Drawings. The proportions of the various individual size of aggregates shall be so adjusted that the grading produces densest mix and the grading curve corresponds to the maximum nominal size adopted for the concrete mix.

13.6 Mixing Concrete

13.6.1 General

- a) Production and control of concrete shall conform to IRS: CBC(CI.5.6).
- b) Concrete shall be mixed in an automatic batching and mixing plant as per this Technical Specifications. Hand mixing shall not be permitted. The mixer or the plant shall be at an approved location that shall be selected considering the properties of the mixes and the transportation arrangements available with the Contractor. The mixer or the plant shall be approved by the Engineer. Unless permitted by the Engineer, all concrete shall be produced in computerised automatic weigh batching plant having printing facilities to printout records of each batch and installed at the Site.
- c) Mixingshallbecontinuedtillmaterialsareuniformlydistributedandauniform colour of the entire mass is obtained, and each individual particle of the coarse aggregate shows complete coating of mortar containing its proportionate amount of cement.
- d) Mixers which have been out of use for more than 30 minutes shall be thoroughly cleaned before putting in a new batch. Unless otherwise agreed by the Engineer, the first batch of concrete from the mixer shall contain only two thirds of the normal quantity of coarse aggregate for cleaning purpose only, and the same shall not be used for concreting purpose. Mixing plant shall be thoroughly cleaned before changing from one type of mix to another.

13.6.2 Batching on site

- a) Batching of concrete shall conform to the provision of IRS: CBC (Cl. 5.6.2) and IS 4925.

- b) All weighing and measuring equipment shall be tested and calibrated as per IS 4926. The results of these tests and calibration shall be submitted to the Engineer.
- c) Addition of water to compensate for slump loss shall not be resorted to nor shall the design maximum water content and maximum water-cement ratio be exceeded. If permitted by the Engineer, additional dose of retarder shall be used to compensate the loss of slump at the Contractor's cost. Re-tempering water shall not be allowed to be added to mixed batches to obtain desired slump.

13.6.3 Ready Mixed Concrete

The Contractor can use RMC, if approved by the Engineer. The source batching plant of RMC shall not change during the course of work. If RMC is used, it shall conform to the provisions laid down in IRS: CBC (CL. 5.7). The batching plant shall have consent to establish and consent to operate permit from Pollution Control Authority. The batching plant shall be operated by trained staff. The batching plant shall have suitable motorable road and a traffic plan to ensure free and safe passage of all vehicles. Waste water and sludge from batching plant shall be at the designated points.

A. Transporting, Placing and Compaction of Concrete

Transporting, placing, compacting and curing of concrete shall be in accordance with IRS: CBC(Cl.8), IS 456 and IS 5892.

i. Transporting

The method of transporting and placing concrete shall have approval from the Engineer. Transportation of concrete shall conform to IRS: CBC (Cl. 8.1, 5.7), if not in contravention to the following provisions.

The mix shall be transported by agitating transit mixers, buckets, pumps etc. or as per approval by the Engineer, without causing segregation and loss of cement slurry and without altering its desired properties with respect to water content, water cement ratio, slump, air content, cohesion and homogeneity.

1m³ of each mix shall be supplied to Site before it is required in the Works to enable the Contractor to carry out workability tests. Under no circumstances shall extra water be added to the concrete after the original mixing is completed.

ii. Pumping

Pumping of concrete shall conform to IRS: CBC (Cl.8.9), if not in contravention to the following provisions.

- a) The type of concrete pump, the diameter of transporting pipe, the route of piping etc. shall be determined considering the pumpability of the concrete to obtain the required quality of concrete after pumping.
- b) The type and the number of concrete pumps shall be determined in consideration of the pumping pressure, the discharge amount, the pumping rate per hour, the environmental conditions of construction site etc.

- c) Prior to pumping design mix concrete, pumping of mortar with the same proportion as of design mix concrete shall be done to prevent loss of mortar in pump due to adherence.
- d) The mortar pumped prior to the concrete pumping shall not discharge into the formwork.

iii. Placing

a) Placing General

- i) Placing of concrete shall conform to the provisions laid down in IRS: CBC(CI.8.2).
- ii) Prior to concreting, detailed planning on the placing system, the arrangement and the number of pumping cars, the position of the inlet for concrete pump, lighting equipment and arrangements for power supply, the sequence and rate of placing, time interval between concrete lifts etc. shall be specified in the Method Statement and the same shall be submitted to the Engineer for approval. Due allowance shall be made to secure enough clear spacing of reinforcement bars which enables concrete to flow through the spaces between reinforcement bars.
- iii) Concrete shall be transported by means which prevent contamination (by dust, rain etc.) segregation or loss of ingredients, and shall be transported and placed without delay.
- iv) Concrete shall be placed directly in its final position without segregation or displacement of the reinforcement, embedded items and formwork. Concrete shall not be placed in water, except as specified. Concrete shall not be dropped through a height greater than 1.5 metres.
- v) All formwork shall be thoroughly cleaned to remove debris etc. before concreting. In addition, the Engineer shall inspect that there is no debris etc. in the formwork before concrete is cast. It shall be examined that there is no abnormality in the formwork and falsework before and during concreting.
- vi) No concrete shall be placed in any part of the structure until approval of the Engineer has been obtained. If concreting did not commence within 24 hours of issuance of approval, then it shall be obtained again from the Engineer. Concreting then shall proceed continuously over the area between the construction joints.
- vii) Except where otherwise agreed by the Engineer, concrete shall be deposited in horizontal layers to a compacted depth of not more than 300 mm.
- viii) Concrete when delivered in the works shall be maintained at a

temperature of not more than 35°C as far as possible.

- ix) Clear spacing between reinforcements shall be secured adequately and lighting equipment shall be arranged adequately in order to visually check the position of inlet of the concrete pump and the filling situation of the concrete during concreting works. In addition, suitable measures shall be taken so that the reinforcement bars do not move and clear cover to the reinforcement bars does not change.
- x) The clear cover shall be uniform and as per the Drawings. Concrete cover blocks used shall be of the same concrete mix as the member and shall contain the binding wire to secure it to the reinforcement. All ends of binding wire shall be carefully turned inside so that they do not project out of concrete cover. Reinforcement bars shall be adequately secured by chairs/ties/hangers so that it maintains its position during casting and vibrating concrete. Ends of the wires used to tie bars shall be bent into the member.
- xi) In case of concreting the horizontal member immediately after the concreting of vertical member is finished, the horizontal member shall be cast after any settlement of concrete of the vertical member ceases in order to prevent settling cracks.
- xii) If bleeding water is present on the surface of concrete during concreting, the bleeding water shall be removed before the following concrete is placed.
- xiii) The Contractor shall ensure that the place where concreting is to be done shall be free of water.

b) Extent of Pours

For piers and pier heads, portal columns the concreting is to be carried out in single stage i.e. in first stage concreting will be from kicker to just below pier head bottom and second stage of concreting will be pier head including shear key and cross girder (in station zone stages as given in drawings for all heights by using tremie/ pumps at the rate not more than 1.5m / hr or as approved by the Engineer.

Floors, roofs and ground slabs shall be placed in a sequence of pours to the approval of the Designer and the consent of the Engineer.

If the use of slip-forms or paving trains is permitted, these limits may be revised. The sequence of pours shall be arranged to minimise thermal and shrinkage strains.

c) Placing Equipment

Concrete shall generally be placed without segregation by pumping or bottom-opening skips. If chutes are used their slopes shall not cause

segregation and spouts or baffles shall be provided.

d) Time for Placing

Concrete and mortar must be placed and compacted within 30 minutes of water being added to the mix or otherwise included via damp aggregates, unless admixtures are in use. Partially-set concrete shall not be used in the Works.

e) Continuity of Placing

Placing in each section of work shall be continuous between construction joints. The Contractor shall make provision for standby equipment. If the placing of concrete is delayed due to breakdown then the Contractor shall erect vertical stop-ends and form a construction joint or remove the concrete already placed and restart after repair of the breakdown, as directed.

f) Placing in Inclement Weather

Placing shall not take place in the open during storms or heavy rains. If such conditions are likely to occur the Contractor shall provide protection for the materials, plant and formwork so that work may proceed. If strong winds are prevalent protection from driving rain and dust shall be provided.

g) Placing in High Temperature and Low Temperature

The temperature of concrete shall not exceed 32o nor below 5oC or the temperature stated in the table of Mixes whichever is the lower at the time of placing concrete. Also the maximum concrete temperature after placing shall not exceed temperature 50oC or 30oC above the concrete temperature at the time of placing whichever is the lower.

"Concrete in hot countries" published by FIP congress at New Delhi 1986 shall be complied with. The procedures the Contractor wishes to employ shall be subject to the Engineer consent

The Contractor shall supply suitable maximum/minimum thermometers and record the shade and sun temperatures at locations where concrete is being placed. Recommendations for cold weather concrete can be had from IS: 7861 (Part 2).

h) Placing at Night

If consent has been given for placing at night or in dark interiors, adequate lighting shall be provided where mixing, transportation and placing are in progress.

i) Placing Under Water

Underwater concrete shall be placed with minimum disturbance of the water. Running water and wave wash shall be controlled. The specified

concrete grade shall be used and the mix design shall provide for good flowing ability.

Tremie pipes, bottom-dump skips or other approved placing equipment shall be used. Segregation shall be avoided.

Placing shall be commenced in approved sections and continued to completion.

The tremie pipe shall be buried in the concrete for at least 1.5m and the pipe must not be emptied until the pour is complete. If a bottom-dump skip is used, the contents shall be covered by canvas or similar before lowering into the water. The doors shall be opened when the skip is resting on the bottom with no tension in the support cable, and the skip shall be lifted gradually so that the concrete flows out steadily.

j) Preparation Before Placing

Before placing concrete for reinforced work on the ground, the formation shall be compacted as specified and a screed of blinding concrete shall be applied to form a surface for construction.

Before placing concrete on or against rock, masonry, brickwork or old concrete, loose material shall be removed and the surface washed down; water seepage shall be stopped or channelled away from the work.

iv. Compaction

- a) Compaction of concrete shall conform to the provisions laid down in IRS: CBC (C1.8.3).

Additional vibrators in serviceable condition shall be kept at site so that they can be used in the event of breakdowns. Concrete shall be compacted before setting commences and shall not be subsequently disturbed.

- b) Internal (needle) and surface (screed board) vibrators of approved make shall be used for compaction of concrete. Internal vibrators shall be inserted in an orderly manner. The distance between insertions shall be 500 mm or less. The vibrator shall be made to operate at a regular pattern of spacing. The effective radii of action will overlap approximately half a radius to ensure complete compaction.
- c) Internal vibrators shall be used for compaction of concrete in foundations, columns, buttresses arch section, slabs etc, and if required surface vibrators shall also be used. Depending on the thickness of layer to be compacted, 25 mm, 40 mm, 60 mm and 75 mm dia internal vibrators will be used. The concrete shall be compacted by use of appropriate diameter vibrator by holding the vibrator in position until:
- i) Air bubbles cease to come to surface.
 - ii) Resumption of steady frequency of vibrator after the initial short period of drop in the frequency, when the vibrator is first inserted.

The vibration shall be done till the tone of the vibrated concrete becomes uniform. To achieve an even and dense surface free of aggregate pockets, vibration shall be supplemented by tamping or rodding by hand in the corners of forms and along the form surfaces while the concrete is plastic.

- iii) Flattened, glistening surface, with coarse aggregates particles blended into it appears on the surface.
 - iv) Use of curing compounds may be permitted with specific approval of Engineer.
- d) After the compaction is completed, the vibrator should be withdrawn slowly from the concrete so that concrete can flow in to the space previously occupied by the vibrator. To avoid segregation during vibration the vibrator shall not be dragged through the concrete nor used to spread the concrete. The vibrator shall be made to penetrate, into the layer of fresh concrete below if any for a depth of about 150mm. The vibrator shall be made to operate at a regular pattern of spacing. The effective radii of action will overlap approximately half a radius to ensure complete compaction.
- i) To secure even and dense surfaces free from aggregate pockets, vibration shall be supplemented by tamping or rodding by hand in the corners of forms and along the form surfaces while the concrete is plastic.
 - ii) A sufficient number of spare vibrators shall be kept readily accessible to the place of deposition of concrete to assure adequate vibration in case of breakdown of those in use.
 - iii) Form vibrators whenever used shall be clamped to the sides of formwork and shall not be fixed more than 450 mm above the base of the new formwork and concrete shall be filled not higher than 230mm above the vibrator. The formwork must be made specially strong and watertight where this type of vibrator is used.
 - iv) Care must be taken to guard against over vibration especially where the workability of the concrete mix is high since this will encourage segregation of the concrete.
 - v) Plain concrete in foundations shall be placed in direct contact with the bottom of the excavation, the concrete being deposited in such a manner as not to be mixed with the earth. Plain concrete also shall be vibrated to achieve full compaction.

14 Construction Joints

- a. Construction joints shall be avoided as far as possible and in no case the locations of such joints shall be changed or increased from those shown in the drawings, unless otherwise approved by the Engineer.

- b. Where provision of construction joint is unavoidable, the location, direction and construction method of construction joint shall be determined in consideration of the structural strength, durability and appearance of the structure. Concreting shall be carried out continuously upto the construction joints. Construction joints shall conform to the provisions laid down in IRS: CBC (Cl. 8.5 and Annexure - B). The Contractor shall submit Method Statement on the construction joints which shall be subject to the consent of the Engineer prior to concreting works.
- c. The location of the construction joints and their arrangement, procedure for surface preparation of construction joint and sequence of concreting shall be subject to the consent of the Engineer. Construction joints shall be located at locations where the shear force is minimum. The joints shall be provided in a direction perpendicular to the member axis. Sequencing of concrete placement shall be organized in such a way that cold joints are totally eliminated. Properly designed reinforcement shall be provided prior to casting of the next lift for transfer of full tensile stress across the joints.

15 Expansion, Contraction and Movement Joints

- a. Expansion, contraction and other movement joints shall be incorporated in the works as shown on the Drawings.
- b. Where shown on the Drawings approved, expansion joint fillers shall be supplied and installed. Filler material shall be stored flat on a dry surface adequately protected from rain or moisture in such a way that the material does not deteriorate. Filler material which has been damaged or has started to deteriorate shall not be incorporated in the works.
- c. Movement joints shall be sealed with an approved sealant applied in strict accordance with the manufacturer's instructions to the dimensions shown on the Drawings. The surface of the concrete to which the sealant is to adhere shall be straight and cleaned of all filler material, dirt, oil, grease and other matter. The sealant shall be applied by methods recommended by the manufacturer so that the sealant is brought flush to the surface of structure and a smooth surface is achieved. Excess material and spillage shall be properly cleaned off and removed.
- d. Dowel bars shall be installed and cast in across the movement joint where shown on the Drawings. The bars shall be straight with clean cut ends of the diameters and lengths as
- e. shown on the Drawings or in the Schedules. Cutting and cleaning of the dowel bars shall comply with the requirements of this Specification.
- f. The bars shall be firmly supported in the positions shown on the Drawings so that they remain accurately parallel and are not displaced during the casting of the concrete in the first part of the structure. After the concrete has hardened and the formwork removed, the projecting ends shall be cleaned of all concrete spillage and painted with two coats of an approved bituminous paint and caps shall be fitted to the free ends of the bars. Dowel bar end caps shall be of cardboard or other material, of correct diameter for the dowel bar and of sufficient length to allow the specified movement of the two adjacent concrete structures. They shall be manufactured

expressly for this purpose by an approved manufacturer.

- g. The Contractor shall take care to protect the projecting ends of dowel bars from bending or other damage prior to concreting the succeeding bay. The bituminous paint shall be applied as soon as practicable, but end caps shall not be fitted until immediately prior to the succeeding concreting operations.

16 Bolts, Inserts and Openings

- a. All fixing blocks, brackets, built in bolts, holes, chases, etc., shall be accurately set out and formed and carefully sealed prior to the concrete being placed. No cutting away of concrete for any of these items shall be done without the permission of the Engineer-in- Charge.
- b. Bolts and other inserts to be cast into the concrete shall be securely fixed to the formwork in such a way that they are not displaced during the concreting operations, and that there is no loss of materials from the wet concrete through holes in the formwork.
- c. Unless shown otherwise on the Drawings or the Engineer has given consent, reinforcement shall be locally moved so that the minimum specified cover is maintained at the locations of inserts, holes, chases, etc.
- d. Temporary plugs shall be removed and the threads of cast in bolts shall be proved to be free and shall be greased before handing over any part of the Works. Construction joints in all concrete work shall be made as directed by the Engineer. Where vertical joints are required, these shall be shuttered as directed and not allowed to take the natural slope of the concrete.

17 Concreting under Special Conditions

Concreting under special conditions shall conform to the provisions laid down in IRS: CBC.

17.1 Concreting in Extreme Weather Conditions

Concreting in extreme weather conditions shall conform to the provisions laid down in IRS: CBC (Cl. 8.6.1).

17.2 Concreting under Water

- a. Concreting underwater and seawater shall conform to the provisions laid down in IRS: CBC (Cl. 8.6.2 and Cl. 8.6.3), where not contravening to the following provisions.
- b. When it is necessary to deposit concrete under water, the methods, equipment, materials and proportions of mix to be used shall obtain approval of the Engineer, prior to the commencement of any work.
- c. Concrete shall not be placed in water having a temperature below 5°C. The temperature of the concrete, when deposited, shall neither be less than 16 °C nor more than 35°C.
- d. All underwater concreting shall be carried out by tremie method as described in IRS: CBC (CL.8.6.2) only, using tremie of appropriate diameter. The number and spacing of the tremie shall be worked out to ensure proper concreting. The tremie concreting when

started shall continue without interruption for the full height of the member being concreted. The concrete production and placement equipment shall be adequate to enable the underwater concrete to be completed uninterrupted within the stipulated time. Necessary standby equipment shall be available for emergency situation.

- e. In case of withdrawal of tremie out of the concrete either accidentally or to remove a choke in the tremie with the approval of the Engineer, the tremie shall be reintroduced in the following manner to prevent impregnation of laitance or scum lying on top of the concrete deposited in the bore. The tremie shall be gently lowered on to the old concrete with very little penetration initially. A vermiculite plug shall be introduced in the tremie. Fresh concrete of slump between 150 mm and 175 mm shall be filled in the tremie which will push the plug forward and will emerge out of the tremie displacing the laitance or scum. The tremie shall be pushed further in steps making fresh concrete sweep away the laitance or scum in its way. When tremie is buried in for about 0.60m to 1.0 m, concreting may be resumed.
- f. In case of concreting through tremie or such pipes which are subsequently withdrawn, the concrete shall be placed in adequate quantity to ensure that during withdrawal of the tube, a sufficient head of concrete is maintained to prevent the inflow of soil and water or bentonite slurry.
- g. No concrete shall be allowed to come in contact with seawater within 72 hours of casting.

17.3 Concreting under Aggressive Soils and Water

Concreting under aggressive soils and water shall conform to the provisions laid down in IRS: CBC (Cl. 8.6.4).

18 Curing of Concrete

18.1 General

- a. Concreting operations shall not commence until adequate arrangements for curing of concrete have been made by the Contractor. Curing and protection of concrete shall commence after the concrete has set hard enough, to with stand stresses due to curing work and does not get damaged, in order to protect it from the following:
 - i. Premature drying out, particularly by solar radiation and wind.
 - ii. High internal thermal gradients.
 - iii. Leaching out by rain and flowing water.
 - iv. Rapid cooling during the first few days after placing.
 - v. Low temperature.
 - vi. Vibration and impact which may disrupt the concrete and interfere with its bond to there reinforcement.
- b. Where members are of considerable size and length, with high cement content, accelerated curing methods may be applied, as approved by the Engineer.

18.2 Curing Procedure

- a. In order to ensure the required quality of concrete in terms of parameters such as strength, durability and permeability, concrete shall be cured adequately, being kept at a temperature and humidity necessary to be hardened within a certain period of time after concreting, in order not to be affected by harmful effects such as low or high temperature, rapid temperature change, drying, loading and impact loading.
- b. Curing of concrete shall conform to the provisions laid down in IRS: CBC (Cl.8.4). Approved curing compounds shall be used in lieu of moist curing, with the approval of the Engineer, particularly for all vertical faces and inaccessible areas, conforming to IRS: CBC (CL. 8.4.2).

18.3 Finishing

Finishing shall conform to the provisions laid down in IRS: CBC (Cl. 6.2.4), if not in contravention to the following provisions:

- a. Immediately after removal of forms, exposed bars or bolt, if any, shall be cut inside the concrete member to a depth of at least 50 mm below the surface of the concrete and the resulting holes shall be filled with cement mortar of dry pack consistency.
- b. All construction and expansion joints in the completed work shall be left carefully tooled and free of any mortar and concrete. Expansion joint filler shall be left exposed for its full length with clean and true edges.
- c. The finished surfaces of concrete after removal of form work shall be such that no touching up is required. All finsca used by form joints, if any, shall be ground using electric sur face grinder.
- d. Immediate Lyon removal of forms, before any defects are rectified, the concrete work shall be examined by the Engineer.
 - i. Exposed concrete surfaces shall be smooth and even, originally as stripped, without any finishing or rendering. The Contractor shall exercise special care and supervision of formwork and concreting to ensure that the cast members are made true to their sizes, shapes and positions. The work that has sagged or contains honeycombing to an extent which is detrimental to structural safety or architectural appearance shall be rejected. Honeycombed parts of the concrete, including other surface defects in the concrete, shall be removed by the Contractor as per the methods which do not affect the strength of adjoining concrete and as per approval of the Engineer. In the final finish, no honeycombing is allowed.
 - ii. Part of defective concrete thus removed shall be recast using fresh concrete of same grade, as approved by the Engineer without any additional cost. For that purpose, the Contractor shall prepare a comprehensive work procedure and obtain approval of the Engineer. No additional payment shall be made for repair of the concrete. The Contractor shall ensure that no air bubbles are formed on the exposed surface. Concrete pouring sequence, vibration methodology etc. shall be planned to ensure that air bubbles are

not formed. All materials, sizes and layouts of formwork including the locations for their joints shall have approval from the Engineer prior to the commencement of the works.

- iii. After the finishing works, cracks which occurred in the surface of concrete until the concrete starts to set shall be removed by refinishing or tamping.
- e. The top face of a slab intended to be surfaced with other material shall be left with a spaded finish.
- f. Chemical surface retarders, if approved by the Engineer, shall be used to produce an exposed aggregate finish, provided the Contractor demonstrates that the durability of the concrete surface is not reduced.

19 Inspection, Tests and Standards of Acceptance

- a. The Contractor shall submit test certificates from the manufacturer or supplier of materials along with each batch of material(s) delivered to site.
- b. The Contractor shall set up a field laboratory with necessary equipment for testing of all materials & finished products to be used in the construction. The laboratory must have riffle divider of adequate capacity as approved by the Engineer for preparation of lab sample for sieve analysis of aggregates.
- c. The test in go falls the materials shall be carried out by the Contractor at the field laboratory or from the laboratory approved by the Engineer and in the presence of the Engineer. The Contractor shall make all the necessary arrangements and bear the entire cost for the same.
- d. Tests which cannot be carried out in the field laboratory shall be done at the Contractor's cost at any recognized laboratory or testing establishments having NABL certification and duly approved by the Engineer.
- e. If materials are brought from abroad, the cost of sampling or testing, whether in India or abroad, shall be borne by the Contractor. The Contractor shall provide and maintain on site, until the works are completed, at all times the equipment and staff required for carrying out these tests.

20 Quality Control of Concrete

- a. The Contractor shall carry out the following tests for concrete, at the site of placing, and ensure that they comply with appropriate provisions of Indian and/or other standards, as may be applicable:
 - i. Slump test for concrete: The frequency of slump test shall be as follows:
 - ii. Case 1: If the site of placing is at the same area as the concrete plant installed, then it shall be conducted once in every hour, as per IS1199(Cl. 5.0) and IS7320.
 - iii. Case2: Other than Case1, it shall be conducted once in each delivery of transit mixer, as per IS 1199 (CL. 5.0) and IS 7320.
 - iv. Tolerance for slump shall conform to IS4926(Cl.6.2.1).

- v. Compressive and Flexural strength of concrete: Sampling, Strength tests and Acceptance criteria of concrete shall conform to IRS: CBC (Cl. 8.7) according to the type of concrete grade.
 - vi. Chloride ion content test: It shall be conducted as per IS:15949 once a week. Chloride ion content shall be 0.43kg/m³ or less.
 - vii. Relative Density and pH value of plasticizer (if used): The test shall conform to IS9103(Cl.7.1, Cl.10.0, Annexure-E) and the tolerances shall be as specified in IS9103(Cl. 9.0, Table-2).
 - viii. Temperature of concrete shall be verified once in each slump test.
 - ix. The concrete shall be verified for permeability and the test procedure along with tolerances shall conform to IRS: CBC (Cl. 5.4.2, Appendix - G). The frequency of test shall depend up on the change in design mix or change in source of material used in the work. However, the Engineer shall select random batches of concrete for examination at his discretion, and any time during concreting. Sampling shall generally be done at the point of discharge from the mixer and at placing point. The concrete shall pass the permeability test if it is properly compacted and the water penetration depth in the broken core is less than 25mm.
- b. It is the complete responsibility of the Contractor to redesign the concrete mixes as per the standard methods that have been approved and to produce there in forced concrete conforming to the specifications. The Contractor shall have competent staff to carry out this work.
 - c. After the completion of the quality control checks of concrete, the Contractor shall immediately report the test results to the Engineer by submitting quality control records of the concrete.

21 Inspection of Concrete

- a. Inspection shall be carried out by the Contractor, after the removal of form work. Also, additional inspection shall be carried out if instructed by the Engineer.
- b. Inspection shall be carried out as per approval of the Engineer for the Method Statement, incorporating the test procedures specified in Table below:

Table: Inspection of Concrete Surface Condition

Measurement Items	Inspection Method	Place to be Inspected
Presence or absence of honey combing, cold joint, discoloration, and cracking	Visual inspection at point-blank range	All parts
Presence or absence of cavity, float, and cracking	Hammering Inspection	As per approved Method Statement,

Clear cover to the outermost reinforcement	Non-destructive test using a probe	and as directed by the Engineer
--	------------------------------------	---------------------------------

- c. Additional non-destructive tests (NDT) on the hardened concrete in the structure as a whole or any finished part of the structure where necessary, or directed by the Engineer, shall be carried out as laid down in IRS: CBC (CL. 18.3).
- d. The Contractor shall report the inspection results along with the location to the Engineer immediately after the inspection. The forms generated from the probes during the inspection shall be attached to the records.
- e. If defects such as deleterious cracking, spalling, deformation and finishing defects or damages caused by the Contractor are noticed from the results of the inspection, no repair work shall be commenced without prior permission taken from the Engineer.
- f. Counter measures against the defects shall be subject to approval of the Engineer. In this case, “repair work” refers to all actions which make alterations to the surface of concrete after the removal of formwork (including plastering etc.). If repair work is required, the Contractor shall submit Method Statement on the repair work and shall obtain approval of the Engineer for the same, prior to the commencement of repair work. During the repair work, the Contractor shall record about the work, and shall report to the Engineer on the results of the work immediately after the repair work has finished.
- g. If cracks develop in concrete construction, which in the opinion of the Engineer may be detrimental to the strength of the construction, the Contractor, at his own cost, shall dismantle the construction, carry away the debris, replace the construction and carry out all consequential work thereto.
- h. If any cracks develop in the concrete construction, which in the opinion of the Engineer, are not detrimental to the stability of the construction, the Engineer shall decide whether such cracks are required to be grouted. The Contractor shall grout such cracks as decided by the Engineer with polymer cement grout of approved quality at his own risk and cost.
- i. External crack width shall be restricted to 0.2mm or less on all concrete structures, unless otherwise specified in the Drawings/Design.

ADDITIONAL TESTS FOR CONCRETE:

As frequently as the Engineer may require, additional testing shall be carried out for concreting in addition to mandatory test specified in CPWD specifications 1996/2002 / relevant IS Code / MOST/MORTH Specifications.

22 Non-Destructive tests for concrete

a) Ultrasonic pulse velocity test

b) Rebound hammer test

In order to determine the following properties of concrete, non-destructive tests for concrete

(ultra-sonic pulse velocity test and rebound hammer test) in accordance with IS 13311(Part 1 and Part 2) shall be carried out.

- i. the homogeneity of concrete
- ii. the presence of cracks, voids and other imperfections
- iii. changes in the structure of the concrete which may occur with time
- iv. the quality of the concrete in relation to the standard requirements
- v. the quality of one element of concrete in relation to the another, and
- vi. the values of dynamic elastic modulus of the concrete

In view of the limitations of each method of the non destructive testing of the concrete, it is essential that the results of tests obtained by one method should be complemented by other tests and each method should be adopted very carefully.

23 Permeability test for Concrete:

The concrete will be verified for permeability by the following procedure and shall confirm to IS: 3085-1965 – „Permeability of Cement Mortar & Concrete“, Section 1717.7.5 of MOST Specification and DIN 1048.

- a) The Engineer shall select random batches of concrete for examination at his discretion and sampling will generally be done at the point of discharge from the mixer and at placing point.
- b) From the batches thus selected two concrete cylinders shall be made in accordance DIN 1048.
- c) All cylinders shall be made, cured, stored, transported and tested in accordance with clause 1717.7..5 of MOST Specifications. The tests shall be carried out in a laboratory approved by the Engineer.
- d) At least two cylinders shall be made on each day's concreting until 60 cylinders have been made for each grade of concrete. The cylinders will be tested as per the procedure, given in Clause (e) next.
- e) Test Procedure:

The permeability of concrete will be verified by the following procedure:

- i. Prepare a cylindrical test specimen 150 mm dia and 160mm high.
- ii. After 28 days of curing, test specimen will be fitted in a machine such that the specimen can be placed in water under pressure up to 7 bars. The typical machine shall be similar to one shown in Appendix 1700/II of MOST.
- iii. At first a pressure of one bar is applied for 48 hours, followed by 3 bars for 24 hours and 7 bars for next 24 hours.
- iv. After the passage of the above period, the specimen is taken out and split in the middle by compression applied on two round bars on opposite sides above and below.

- v. The water penetration in the broken core is measured with scale and the depth of penetration assessed in mm (max permissible limit 25 mm).
- f) Acceptability Criteria:

The concrete shall pass the permeability test if it is properly compacted and is not considered permeable when tested as per DIN, and the water penetration in the broken core is less than 25mm.

No extra payment shall be made for this test and cost of the same will be included in his rate for concrete work.

24 Chlorides in Concrete

The levels of equivalent acid-soluble chlorides as NaCl ($\text{Cl} \times 1.65 = \text{NaCl}$) in the constituents of concrete as stated elsewhere are indicative and are subject to the over-riding limits for the mixes.

The total estimated content as a percentage by weight of the cement in the mix shall not exceed the following limits: -

- (a) For reinforced concrete
 - 0.5% if made with Ordinary Portland Cement (OPC)
 - 0.1% if made with Sulphate Resistant Portland Cement (SRPC)
- (b) For mass concrete
 - 1.0% if made with OPC
 - 0.1% if made with SRPC

The Contractor shall test the constituents of the concrete to establish these contents as provided for elsewhere in this Specification.

In addition, regular tests to BS 1881: Part 6 for chloride content shall be made on the hardened concrete. The following values are acceptable: -

- (i) For reinforced concrete made with OPC
 - 95% of the test results less than 0.40% NaCl by weight of cement and no result greater than 0.50% NaCl by weight of cement.
- (ii) For reinforced concrete made with SRPC
 - 95% of the test results less than 0.1% NaCl by weight of cement and no result greater than 0.14% NaCl by weight of cement.
- (iii) For mass concrete made with OPC
 - 95% of the test results less than 1.0% NaCl by weight of cement, and no result greater than 1.30% NaCl by weight of cement.
- (iv) For mass concrete made with SRPC
 - 95% of the test results less than 0.2% NaCl by weight of cement and no result

greater than 0.25% NaCl by weight of cement.

In the event that the SRPC used contains a proportion by weight of tri-calcium aluminate which approaches 4 - 8%, then consent may be sought for an appropriate adjustment of the relevant chloride content limits.

25 Sulphates in Concrete

The level of acid-soluble sulphates (SO₃) in the mix shall be no greater than:

Coarse aggregate 0.4% by weight

Fine aggregate 0.4% by weight

Water 500 mg/l

The total estimated sulphate content (SO₃) of the mix including that present in the cement shall not exceed 3.7% by weight of cement in the mix.

In addition, regular tests to BS 1881: Part 6 shall be made on the hardened concrete to determine the total sulphate content, which shall not exceed 4% by weight of cement in the mix.

Permissible Level of Chloride and Sulphates

The permissible level of chlorides and sulphates quoted in the above Subsections shall not be considered as mean values for the whole of the Works, but shall apply to any concrete.

Concrete for water-retaining structures shall in addition be as per IS: 3370.

26 CRACKS:

If cracks, which in the opinion of the Engineer may be detrimental to the strength of the construction, develop in concrete construction, the Contractor at his own expense shall test the structure as specified in "Loading Tests" of these Specifications.

If under such test loads the cracks develop further, the Contractor shall dismantle the construction, carry away the debris, replace the construction and carry out all consequential work thereto.

If any cracks develop in the concrete construction, which in the opinion of the Engineer-in-Charge, are not detrimental to the stability of the construction, the Contractor at his own expense shall grout the cracks with neat cement grout or with other composition as directed by Engineer-in-Charge and also at his own expense and risk shall make good to the satisfaction of the Engineer all other works such as plaster, moulding, surface finish, which in the opinion of the Engineer have suffered damage either in appearance or stability owing to such cracks. The Engineer's decision as to the extent of the liability of the Contractor in the above matter shall be final and binding.

External crack width shall be as per IRS: CBC with latest addendums.

27 DEFECTIVE CONCRETE:

Should any concrete be found honeycombed or in any way defective, such concrete shall be cut out partially or wholly by the Contractor and made good at his own expense. If

Engineer feels that repaired structure will not be having same strength or shape or uniformity with other exposed surface as original desired structure / original structure, the same shall be rejected by Engineer and required to be dismantled and disposed by contractor at his own cost as instructed by Engineer-in-Charge. Decision of the Engineer shall be final and binding in this regard.

28 EXPOSED FACES, HOLES AND FIXTURES:

On no account shall concrete surfaces be patched or covered up or damaged concrete rectified or replaced until the Engineer or his representative has inspected the works and issued written instructions for rectification. Failure to observe this procedure will render that portion of the works liable to rejection.

Holes for foundation or other bolts or for any other purposes shall be moulded, and steel angles, holdfasts or other fixtures shall be embedded, according to the drawing or as instructed by the Engineer.

29 FINISHES:

Unless otherwise instructed the face of exposed concrete placed against formwork shall be rubbed down immediately on removal of the formwork to remove irregularities. The face of concrete for which formwork is not provided other than slabs shall be smoothed with a float to give a finish equal to that of the rubbed down face, where formwork is provided. The top face of a slab which is not intended to be covered with other materials shall be leveled and floated to a smooth finish at the levels or falls shown on the drawings or as directed. The floating shall be done so as not to bring an excess of mortar to the surface of the concrete. The top face of a slab intended to be surfaced with other material shall be left with a spaded finish. Faces of concrete intended to be plastered shall be roughened by approved means to form key.

30 CONCRETE FOR FLOORING ON GRADE:

Concrete for flooring on grade shall be placed in alternate bays not exceeding more than 4m x 6m or as specified in the drawings including forming the joints or adjacent bays. The stiff mix shall be thoroughly vibrated and finished to receive the floor finish.

31 GROUTING OF BASE PLATES & BOLT HOLES:

a) Mixing :

Dry grout should be mixed in a mechanical mixer: the conventional 200/400-litre capacity concrete mixer can be used to mix four bags of dry grout; alternatively, paddle type mortar mixers can be used. The quantity of grout to be mixed at one time should not exceed that amount which can be placed in approximately 10 to 15 minutes.

b) Batching :

Batching of grout by fraction of a bag is not allowed. The quantity of mixing water should be the minimum commensurate with workability, compaction, and filling of the grout in all corners and crevices. Mixing should be done for a minimum of three minutes to obtain a fluid grout of uniform consistency.

c) Cleaning and preparation of the surface :

The base concrete should be clean and strong, and its surface should be properly hacked; all dust should be removed suction or compressed air. The surface should be thoroughly wetted with water for several hours. Before the grout is poured, all free water should be removed and the flat surfaces coated with a thin cement slurry.

d) Restraint :

Heavy back-up blocks of timber or concrete should be fixed on all sides of the base plate to prevent escape of the grout, when poured through the openings provided in the base plate. Adequate restraint must be ensured on all the sides for a period of 7 days to obtain effective expansion and shrinkage compensation.

e) Curing :

The grout should not dry out where external restraint is provided in the form of form-work, the top opening and all stray openings should be covered with wet sack for at least 7 days.

f) Placing and Compaction :

The grout should be placed quickly and continuously either through the holes in the base plates or from one side only to ensure complete filling without entrapment of air. Grout should be properly spread and compacted by rodding. Excessive vibration should be avoided.

Below the bed plates the grout should be compacted using long pieces of doubled-over flexible steel strapping or chains. The forward and backward movement of the strap or chain will assist in the flow of the grout into place. Steps must be taken to keep the grout in full contact with the underside of the bedplate until the grout sets; maintaining a small head of fresh grout in the forms.

g) Shrinkage Compensated Grout:

Shrinkage compensated grout or non-shrinkable grout of Associated Cement Companies Limited or any other approved manufacturer (Fosroc, Roff, Sikka) should be used. The batching shall be as per the manufacturer's specifications, other procedures being as above.

32 Tolerance

Tolerances for the finished concrete structures shall be as specified in the Contract.

33 Mass Concrete

- a) *Any concrete having minimum dimension of more than 1 m shall be considered mass concrete.*
- b) *In mass concrete core temperature shall not exceed 75°C and differential temperature between core and surface of concrete shall not exceed 20°C.*
- c) *For each grade of mass concrete mock up trial shall be carried out of size 2m x 2m x thickness of mass concrete. Mock up trial shall use thermocouples to measure concrete temperature both near surface and at the core. Thermocouples shall be located*

centrally along the length and width of the mock up. Thermocouple shall be rigidly suspended so that they do not move out of position during casting. The Contractor shall monitor and document the conformance of the trial with the maximum allowable temperature requirement as given above. Result shall be automatically locked at the minimum of hourly intervals and logging shall continue for at least 72 hours or until the core reached ambient temperature, whichever is longer.

- d) The scheme of mock up trial shall be submitted by the Contractor to the Engineer for approval. If there is change in brand/ factory of cement, mock up trial will be required again.*
- e) The Contractor shall carry out temperature monitoring of core temperature and surface temperature of 1st structure of mass concrete to confirm the results of mock up trial.*
- f) Ply shuttering will be preferred. However, if steel plate shuttering is used, insulation will be provided with thermocol.*
- g) No water curing should be carried out for 07 days. Concrete top surface shall be covered with plastic sheets after initial setting of concrete and insulation of plastic sheets by thermocol after final setting of concrete. Vertical shuttering shall remain intact till 07 days or as per directions of the Engineer.*
- h) Detailed report shall be submitted by the Contractor to the Engineer after mock up and 1st structure casting.*
- i) The Contractor shall submit pour plan to the Engineer for approval for each structure of mass concreting. The pour plan shall include pour sequence, infrastructure required (RMC plant, TM, Concrete pump, placing boom), logistic plan, manpower (duties and responsibilities), lab equipment. Mass concrete shall preferably use PPC to reduce core temperature. Concrete placement temperature shall be decided by the results of mock trial and the same shall be followed.*
- j) Thermocouples shall be provided in permanent concrete structures having maximum thickness more than 1m at one location for each additional 500mm thickness above 1m. The scheme of providing thermocouple shall be submitted by the Contractor to the Engineer for approval.*

34 Precast Concrete

34.1 Manufacture Off-Site

- a) Casting of members shall not begin until a NONO has been given by the Engineer to the shop drawings, required computation and method of manufacture.
- b) When the drawings and method of manufacture have been noticed, no changes shall be made without NONO from the Engineer
- c) The Contractor shall inform the Engineer in advance of the date of commencement of manufacture and casting of each type of member.
- d) Concrete reinforcement and workmanship shall be as per IS: 456.

- e) A copy of all cube test results for the precast concrete works shall be sent to the Engineer as soon as these are available.
- f) No members to which the tests relate shall be dispatched to the Site until the tests have been satisfactorily completed and noticed by the Engineer.

34.2 Forms

The design and fabrication of the forms and false work as well as their construction shall be the responsibility of the Contractor. Forms shall be inspected prior to authorizing casting operations. Details shown on the Drawings shall be built into the forms. Worn, damaged, or otherwise unacceptable forms shall be repaired before casting of any member is authorized. The forms may be made either of steel or of plywood. If the Contractor elects to use plywood forms, it shall be high quality plywood, 19mm minimum thickness marine grade subject to approval from the Engineer. Forms shall be structurally adequate to support the members within permissible tolerances. Forms shall be coated with a notified form-release agent prior to use. Anchor devices may be cast into the concrete for later use in supporting forms provided the arrangement has been notified from the Engineer. Bottom/base should be true level without offsets and kinks of designed supports and shutterings over required PCC base with proper drainage arrangement for proper working and curing.

34.3 Curing

Steam curing with approved methodology can be adopted if required, for precast components subject to the approval of Engineer-in-Charge. No extra payment will be made for adopting steam curing. Before concrete products are subjected to any accelerated method of curing, the cement to be used shall be tested in accordance with accepted standards (relevant IS codes) especially for soundness, setting time and suitability for steam curing. In the case of elements manufactured by accelerated curing methods, concrete admixtures to reduce the water content may be allowed to be as permitted by applicable codes of practice subject to the approval of the Engineer-in-Charge. The normal aeration agents used to increase the workability of concrete shall not be allowed. The steam curing of concrete products shall take place under hoods, under chambers or in tunnels. Use of insulated tarpaulin may be permitted. The steam shall have a uniform quality throughout the length of the member. The precast elements shall be stacked with sufficient clearance between each other and the bounding enclosure, so as to allow proper circulation of steam. The surrounding walls, the top cover and the floor of steam curing chamber or tunnel or hood shall be so designed as not to allow more than 1 kcal/m²/h/ deg C. The inside face of the steam curing chamber, tunnel or hood shall have a damp-proof layer to maintain the humidity of steam. Moreover, proper slope shall be given to the floor and the roof to allow the condensed water to be easily drained away. At first, when steam is let into the curing chambers, the air inside shall be allowed to go out through openings provided in the hoods or side walls which shall be closed soon after moist steam is seen jetting out. Preferably, steam should be let in at the top of the chamber through perforated pipelines to allow uniform entry of steam throughout the chamber. In no case shall steam impinge directly on concrete products. The fresh concrete in the moulds shall be allowed to get the initial set before allowing the concrete to come into contact with steam. The regular heating up of

fresh concrete product from 20 °C to 35 °C shall start only after a waiting period ranging from 2 to 5 hours depending on the setting time of cement used. The second stage in steam curing process shall be to heat up the concrete elements, moulds and the surroundings in the chamber. The air-space around the member shall be heated up to a temperature maximum to 70°C at a gradual rate, not faster than 10° per hour. This process shall continue 1 1/2 to 2 1/2 hours depending upon the outside temperature. The third stage of steam curing shall be to maintain the uniform temperature and pressure for a duration depending upon thickness of the section. This may vary from 3 to 5 1/2 hours. The fourth stage of steam curing shall be the gradual cooling down of concrete products and surroundings in the chamber and normalization of the pressure to bring it at par with the outside air. The maximum cooling rate, which is dependent on the thickness of the member, shall not exceed 30° per hour. In all these cases, the difference between the temperature of the concrete product and the outside temperature shall not be more than 60°C for concrete up to M 30 and 75°C for concrete greater than M 45. In the case of light weight concrete, the difference in temperature shall not be more than 60°C for concrete less than M 25. For concrete greater than M 50, the temperature differences may go up to 75°C. After the steam curing is completed, the elements shall be further water cured for about 3 to 7 days.

The curing shall be carried out as per approved Method Statement.

34.4 Storage

When members are stored, they shall be firmly supported only at the points specified.

- a. The accumulation of trapped water and deleterious matter in the units shall be prevented.
- b. Care shall be taken to avoid rust staining and efflorescence.
- c. The area intended for the storage of pre-cast units should be surfaced in such a way that no unequal settlement can occur.
- d. To prevent deformation of slender units, they should be provided with supports at fairly close intervals and should also be safeguarded against tilting. Lifting and handling positions should conform to the Engineer's directions and drawings. In addition, location and orientation marks shall be put on the members, as and where necessary.

34.5 Handling and Transport

- a. Members shall be lifted or supported only at points specified or otherwise given a NONO from the Engineer and shall be handled and placed without impact.
- b. The Contractor shall define the method of lifting, the type of equipment and transport to be used, and the minimum age of the members to be handled and shall submit to obtain approval from the Engineer.

34.6 Protection

At all stages of construction, pre-cast concrete units and other concrete associated there with shall be properly protected to prevent damage to permanently exposed concrete surfaces, specially arised and decorative features.

35 Falsework and Formwork

35.1 General

Falsework and formwork shall conform to the provisions laid down in IRS: CBC (CL. 6.1 to 6.4) and IRC: 87, if not in contravention to the following provisions:

- a. Falsework shall be designed in consideration of appropriate raising (camber) against sinking and deformation due to the weight of the concrete during construction and after completion. Furthermore, the Contractor shall submit the plan of the camber to the Engineer prior to the commencement of works for obtaining approval.
- b. Ties shall not be welded to the reinforcement bars. Clear cover to the end of the ties shall not be less than 25mm. Filling of tie locations after removal of form work shall be carried out with dry pack cement mortar.
- c. The form work shall be of steel plates of proper thickness to give good finish.

35.2 Design of Formwork

- a. The Contractor shall submit the design and drawing of complete formwork (i.e. the forms as well as their supports) to the Engineer, before any erection work commences. If proprietary system of formwork is used, the Contractor shall furnish detailed information to the Engineer. However, the Contractor shall be entirely responsible for the adequacy and safety for formwork.
- b. The foundation of all supports shall be designed to suit the bearing capacity of soil to support the designed loads without settlement.
- c. The Contractor shall prepare detailed shop drawing showing the arrangement of form work for structural members including shoring system, horizontal and diagonal bracing system, details of foundation etc. The sizes of individual members shall be as per the design calculations.

35.3 Finishing of Formwork

- a. Finishing shall conform to IRS: CBC (Cl.6.2.4 and Cl.6.2.5).
- b. Formwork shall be made to produce a finished concrete true to shape, line, levels and dimensions.
- c. Chamfers shall be provided at all angles of the formwork to avoid sharp corners. The chamfers, bevelled edges and mouldings shall be made in the form work itself, conforming to the Drawings.

35.4 Cleaning and Treatment of Forms

Cleaning and treatment of forms shall conform to IRS: CBC(Cl.6.3).

35.5 Specialized Formwork

- a. Specialized form work shall conform to the provisions laid down in IRC:87(Cl.10).
- b. Specialized formwork may be required in the case of slip formwork, underwater concreting etc. Such specialized formwork shall be designed and detailed by competent agencies and a set of complete working drawings and installation

instructions shall be supplied to the Engineer. The site personnel shall be trained in the erection and dismantling as well as operation of such specialized formwork. If proprietary equipment is used, the supplier shall supply drawings, details, installation instructions, etc. in the form of manuals along with the formwork. Where specialized formwork is used, close coordination with the design of permanent structure is necessary.

- c. For slip form, the rate of slipping the formwork shall be designed for each individual case considering various parameters including the grade of concrete, concrete strength, concrete temperature, ambient temperature and concreted mixtures.
- d. In order to verify the time and sequence of striking or removal of specialized formwork, routine field tests for the consistency of concrete and strength development are mandatory and shall be carried out before adoption.

35.6 Inspection of Formwork

- a. The Contractor shall inspect the formwork and shall submit inspection results by "Formwork Assembly Inspection Record" prior to concreting works.

"Formwork Assembly Inspection Record" describes the results of verification of inspection results of the formwork with design documents in which the shape and dimensions of the formwork, clear cover to the outermost reinforcement, effective height etc. are verified. The proposed form of "Formwork Assembly Inspection Record" shall be submitted by the Contractor for approval of the Engineer.

- b. Concreting shall not be allowed unless approved for the formwork by the Engineer.

35.7 Stripping and Removal of Formwork

- a. Stripping time shall conform to the provisions laid down in IRS: CBC(CI.6.4).
- b. The scheme for removal of formwork (i.e., de-shuttering and decentring) shall be planned in advance and submitted to the Engineer for scrutiny and approval. No form work or any part there of shall be removed without prior approval of the Engineer.
- c. The formwork shall be removed in such a manner that does not cause any damage to concrete. Centring shall be gradually and uniformly lowered in such a manner that it permits the concrete to take stresses due to its own weight uniformly and gradually to avoid any shock or vibration.
- d. Where the rear entrance angles in the concrete sections, the formwork shall be removed at these sections as soon as possible after the concrete has set to avoid cracking due to shrinkage of concrete.

35.8 Reuse of Forms

The Contractor shall not be permitted reuse of timber facing formwork brought new on the works for more than 5 times for exposed concrete formwork and 8 times for ordinary formwork. 5 or 8 uses shall be permitted only if forms are properly cared for, stored and repaired after each use. Use of different quality boards or the use of old and new boards in the same form work shall not be allowed. If any other type of special or proprietary form work is used, the number of times they can be used shall be given a NONO from the Engineer.

Annexure OCS-2**REINFORCEMENT STEEL****1. General**

- a) High strength deformed steel bars for concrete reinforcement used in the works shall be Fe 500D TMT, conforming to IS 1786 and manufactured by SAIL/TATA STEEL /JSW STEEL/RINL/JSPL. No rerolled steel shall be used. The Contractor shall produce copy of original challan or voucher as a proof of having purchased the steel reinforcement from manufacturers or their authorized distributors having approval of the Engineer. Reinforcement steel shall be stored as per IS 4082.
- b) Any steel specified for reinforcement shall conform in every respect to the latest relevant Indian Standard Specifications and shall be of tested quality under the ISI Certification Scheme.
- c) All reinforcement work shall be executed in conformity with the drawings supplied and instructions given by the Engineer and shall generally be carried out in accordance with the relevant Indian Standard Specifications IS: 2502- Bending and Fixing of Bars for Concrete Reinforcement.
- d) No work shall be commenced without the Engineer's approval for reinforcement bar bending schedule. The reinforcement bars shall be bent to conform to the dimensions and shape shown in the Drawings in a manner that will not damage the parent material. Bars shall be bent cold. Any reinforcement, which is bent, shall not be re-bent. However, when it is unavoidable to re-bend the reinforcement, the same shall have approval from the Engineer.
- e) Placement of reinforcement shall conform to the provisions laid down in IRS: CBC (Cl. 7.1.3). Cover and spacing of steel shall be uniform and as specified in the specifications and as shown in the Drawings.
- f) Uncoated reinforcement steel shall be protected from rusting or chloride contamination. Reinforcements shall be free of rust, mortar, loose mill scale, grease, oil or paint.
- g) Procurement of reinforcement steel shall be so phased by the Contractor that the storage period before its actual use in the works is limited to the bare minimum as directed by the Engineer.

2. Transportation and Storage

- a) Transportation and Storage shall be undertaken in such a manner that no damage is done to the steel.
- b) Reinforcement steel shall be stored off the ground in separate groups according to size and length. Reinforcement steel, which has been cut and bent according to the schedules provided by the Contractor, shall be marked with bar number, as shown in the schedule, by using weatherproof tag or by placing in marked bins and shall be stored in such a manner as to be readily accessible when required and to facilitate inspection.

- c) A hard base of PCC M 20 shall be provided for stacking of steel to avoid corrosion.

3. Inspection and Testing

- a) Manufacturer's test certificate shall be submitted for each lot of supply brought at the Site by the Contractor. Physical tests shall conform to IS1387, IS1599, IS1608 and IS1786. Independent test on quality of steel from each lot shall be carried out as per IRS: CBC (Cl.4.5.2).
- b) The frequency of tests on reinforcement consignments delivered at site from one manufacturer should be as per IS 1786:2008 (Cl. 11.1).
- c) Specimens required for three tensile tests for each of the different size of bar for each consignment delivered shall be sampled and tested by the Contractor before use at Site. Test results shall be duly supported by graph with respect to stress and strain. If first test of three test samples does not give the specified results, two additional tests shall be carried out. Both retests shall conform to the requirements as specified in IS 1786. The steel shall be rejected otherwise.
- d) Reinforcement steel shall be inspected prior to the commencement of works and assembly on Site. Defective, brittle, excessively rusted or burnt bar shall be discarded. Cracked ends of bars shall be cut out. All reinforcement steel shall be free of loose small scales, rust and coats of paint, oil, mud etc.
- e) The Contractor shall inspect the reinforcement works and submit inspection results by "Reinforcement Assembly Inspection Record". "Reinforcement Assembly Inspection Record" describes the results of verification of inspection results of the reinforcement work with the Drawing in which the diameter, number and length of the reinforcements, position of splices and joints, position and interval of the bent reinforcement bar, type and disposition of cover blocks are verified. The form of "Reinforcement Assembly Inspection Record" shall be proposed by the Contractor for approval of the Engineer.
- f) The Contractor shall obtain approval of the Engineer for reinforcement work prior to the commencement of concrete work.

4. Tolerances and Criteria

- a) Unless otherwise specified by the engineer, reinforcement shall be placed within the following tolerances:
 - i. For overall depth 200 mm or less : $\pm 10\text{mm}$
 - ii. For overall depth more than 200mm : $\pm 15\text{mm}$

The cover shall, in no case, be reduced by more than one third of specified cover or 5mm whichever is less.

5. Lapping and Joints

- a) Lapped Splices: No splicing of bars shall be permitted without prior approval of the Engineer. Lengths of splice, wherever required, shall be as indicated on the drawings

and approved by the Engineer. Lapped splices shall be staggered and located at points along the span where shear stresses are low.

- b) Mechanical Joints: Mechanical coupler shall be used for jointing of reinforcement bars of diameter 25 mm and above. Mechanical coupler shall conform to laid down specification given in Clause 6 below. Mechanical couplers of threaded type with enlargement at connection by cold forging may be used at appropriate locations after prior approval of the Engineer.
- c) Welded Joints: Not permitted

6. Coupler Specifications

a) Introduction

Only cold-forged, parallel threaded mechanical coupler system shall be used. All mechanical couplers shall be of Type 2 (or Class H as specified in IS-16172) and should be simple to install and which can be confirmed by quick visual inspection to have been correctly installed and to have achieved the required full strength connection. Any other types of mechanical coupler systems are not permitted.

The couplers shall be of standard parallel thread type. Ends of the reinforcement bars, which are to be joined, shall be enlarged by cold forging, threaded in such a way that root thread diameter is not lesser than the parent bar to be joined. The coupler shall be of TYPE – II and qualified/Certified as per UK CARES, IS code 16172:2014, ACI 318, ASME, Section III, and Div.2, Caltrans.

Couplers installed shall be strictly in accordance with the manufacturer's recommendations. Couplers shall be located away from high stress zones in the various structural elements and shall be staggered and shall conform to provision of IRS: CBC

All the couplers shall be manufactured in a factory which is ISO 9001:2008 (or higher revision) certified for "Manufacturing of Mechanical Steel Rebar Couplers & Accessories" and also be certified for "Site Management of Threading & Processing of Rebar including Sales and Distribution". All the couplers shall undergo quality checks on uniformity of threads, dimensional accuracy etc. Each coupler shall be clearly stamped indicating batch number and diameter. This number shall be traceable to the original cast. The relevant material mill certificate shall be submitted with supply of a particular lot. The certificate shall give salient material properties. The coupler manufacturer shall operate at least an ISO 9000 approved quality assurance programme or equivalent for the manufacture of couplers.

b) Threading of ends of the reinforcing bars:

The threading activity shall preferably be done at Site. The various stages involved in threading are as given below:

i. Cutting (Rebar End Preparation):

The ends of reinforcement bars shall be cut by mechanical means to get a perfect plane surface perpendicular to the axis of the bar.

ii. Cold forging & threading:

After cutting the ends of the bar shall be enlarged by cold forging such that the area of cross section after threading shall not be less than the area of cross section of the parent bar. The length of cold forging shall be adequate for proposed thread length as per manufacturer's design. Threading shall be done on threading machine. The threads shall be square parallel type to suit the couplers. The thread length and depth shall be as per manufacturer's design. After threading is completed, the threaded length of the bars shall be protected by providing plastic end caps before taking the bars out of the shop.

c) Quality control in making of threads:

Double forging of bars is not permitted. In case of improper cold forging the forged of the bar shall be square cut and fresh cold forging shall be undertaken. 100% threading at threaded rebars shall be checked with 'go' and 'no go' gauges for the correctness of the thread profile on the rebar. A proper record for same shall be maintained at site.

d) Qualification tests

The coupler shall be qualified as per IS code 16172:2014, ACI 318, ASME - Section III, and Div.2, Caltrans and must have conducted & qualified for the following tests:

i. Static tensile test

Mechanical connections shall be tested for all reinforcing rebar sizes. For each rebar size, a minimum of three connections (3 joints + 1 Parent bar) in each load direction shall be tested in accordance with ASTM A370 test method to meet code requirement. A tensile test on an unsliced specimen from the same bar used for the spliced specimens shall be performed to establish actual tensile strength. The tensile strength of an individual splice system shall not be less than the 125% of the specified minimum yield strength (f_y of rebar) of the spliced bar.

ii. Cyclic tension and compression test

Mechanical connections shall be tested in all reinforcing rebar sizes. For each rebar size, a minimum of three connections shall be tested for cyclic tension & compression test. Each specimen shall withstand cycles of stress variation of the specified minimum yield strength of the reinforcing bar. The test should be carried out as per the table mentioned below:

Loading Stages and Cycles per stage for cyclic load test

Stage	Tension	Compression	Cycles
1	0.95 f_y	0.5 f_y	20cycles
2	2 ϵ_y	0.5 f_y	4cycles
3	5 ϵ_y	0.5 f_y	4cycles

Note:

f_y is specified yield strength of the reinforcing bar.

ϵ_y is the strength of reinforcing bar at actual yield stress

iii. Cyclic tensile test

Mechanical connections shall be tested in all reinforcing rebar sizes. For each rebar size, a minimum of three connections shall be tested for low cyclic tensile test. Each specimen shall withstand 100 cycles of stress variation from 5% to 90% of the specified minimum yield strength (f_y) of the reinforcing bar. One cycle is defined as an increase from the lower load to the higher load & return.

iv. Low cycle fatigue test (for 10,000 cycles)

Fatigue test shall be conducted on splice sample from +173 Mpa to -173 Mpa for 10,000 cycles. A sine wave form @ 0.5 Hz shall be followed for bar dia 36 mm & above and 0.35 Hz shall be followed for bar dia less than 36 mm. Test shall be conducted confirming to IS 16172:2014 & Caltrans specifications. Past certificates for low cycle fatigue test shall be accepted. However these should not be more than 3 years old.

v. High cycle fatigue test (for 2,000,000 cycles)

In high cycle fatigue test, the test specimen is subjected to an axial tensile load which varies cyclically according to the sinusoidal wave form of constant frequency in the elastic range, as accordance with IS-16172. Past certificates for high cycle fatigue test shall be accepted. However these should not be more than 3 years old.

vi. Slip test

Slip Test Shall be performed on each diameter coupler specimen as per ASTM A 370 section 10. Test shall be conducted conforming to IS 16172:2014 & Caltrans specifications. Total slip shall not exceed the max value of 0.1 mm.

vii. Proof loading test

Every cold-forged, threaded bar end shall undergo a proof load test prior to leaving system supplier's workshop. Every threaded bar must be subjected to proof load testing to a minimum test loading of 75% of the characteristic strength (theoretical f_y). The system supplier shall essentially install a proof load tester equipment within its threading workshop premises and ensure to test each and every threaded bar. A positive indication shall be marked on the rebar to indicate that this operation has been carried out.

Note: All three steps involved in the preparation of mechanical joints i.e end cutting of reinforcement, cold forging and threading shall be performed by the coupler manufacturer either at site or at supplier's workshop. Proof load testing of each threaded bar end shall also be performed by the

manufacturer at a NABL approved lab which will be witnessed by the Engineers Representative. Contractor shall submit the test certificates of joint strength issued by the manufacturer.

7. INSTALLATION OF COUPLERS IN THE FIELD:

The installation of couplers in the field, for joining reinforcing bars shall be undertaken by trained manpower and as per manufacturer's instructions. Threads of both the couplers and the bars shall be thoroughly cleaned just before installation. Where couplers are cast-in the concrete, but connection is not to be completed immediately, the couplers shall be internally greased and plastic capped to a protection detail acceptable to the engineer. This cap shall be removed only when next bar is to be attached, then the same to be cleaned before joining the next bar.

The Contractor shall arrange for a suitably qualified manufacturer's representative experienced in mechanically connecting reinforcement to be present at site before the start of work for initial training of personnel, and also to demonstrate the equipment and techniques as necessary. The threading workshop is to be fully supervised by the manufacturer's representative.

The Contractor shall submit to the Engineer, for his approval a method statement duly approved by the manufacturer for mechanically connecting the reinforcement and for the installation and verification in the field. All activities of manufacture of mechanical joint i.e. cutting, forging and threading shall be carried out under the overall guidance of the manufacturer at the rebar yard with necessary machines and equipment supplied by the manufacturer. The Contractor shall also submit certificate for satisfactory performance of the mechanical joint from the manufacturer for all the coupled bars. This shall take into account any special requirements for horizontal, vertical and inclined couplers and shall include a rectification procedure, if the connection is incorrectly made. It shall also cover the correct methodology for handling of tools and equipment for mechanical connection on site. The following information shall also be included:

- i) Requirements for cleanliness
- ii) Equipment for threading bars
- iii) Method of locking the connections on both rebars
- iv) Method of verification of final rebars alignment and coupler integrity

Each coupler shall be visually examined prior to use to ensure the absence of rust and of any foreign material on the inside surface. All completed couplers shall be inspected and verified in accordance with the approved QAP. The Contractor shall ensure the acceptance of the Engineer for a procedure for documenting the inspection of the couplers. The Contractor shall retain inspection records and shall submit copies to the Engineer-in-Charge within 7 days. The Couplers that do not meet the acceptance shall be completely removed and the bars re-connected as required.

6. BAR BENDING AND BAR BENDING SCHEDULE:

All bars will be carefully and accurately bent by approved means in accordance with IS: 2502, and relevant drawings. It shall be ensured that depth of crank is correct as per the bar cutting and bending schedule and bent bars are not straightened for use in any manner that will injure the material.

Prior to starting bar bending work, the Contractor shall prepare bar bending schedule from the structural drawings supplied to him and get the same approved by Engineer. Any discrepancies and inaccuracies found by the Contractor in the drawings shall be immediately reported to the Engineer whose interpretation and decision there to, shall be accepted.

7. SPACING, SUPPORTING AND CLEANING:

- a) All reinforcement shall be placed and maintained in the positions shown on the drawings to be prepared by contractor.
- b) The Contractor shall provide approved types of supports for maintaining the bars in position and ensuring required spacing and correct cover of concrete to the reinforcement as specified on the drawings. Cover blocks of required shape and size, Chairs and spacer bars shall be used to ensure accurate positioning of reinforcement. Spacers or chairs should be placed at a maximum spacing of 1m and closer spacing sometime be necessary. Cover blocks of approved proprietary should be pre-packaged free flowing mortars (Conbextra HF of Fosroc or equivalent). Cover blocks of concrete (not sand cement mortar) should be of the same strength as that of the surrounding concrete and properly compacted and vibrated on a vibrating table. They shall be cured for a minimum period of 14days before they are used in the works. The cost of cover block shall be deemed to have been included in the rates.
- c) Cover blocks shall be firmly placed at appropriate intervals to maintain specified concrete cover to the reinforcement. The number of cover blocks to be provided shall generally be about 4 pieces per m² for the bottom surface of the member and about 2-4 pieces per m² for the side surface of the member. Cover blocks shall be made of concrete or mortar having quality equal to or higher than that of the parent concrete.
- d) Bars must be cleaned, before concreting commences, of all scale, rust or partially set concrete which may have been deposited there during placing of previous lift of concrete. On no account shall the bars be oiled or painted nor shall mould oil used on the formwork be allowed to come in contact with the bars. Cement wash to bars will not be permitted.
- e) Only Fe500D TMT bars complying to IS:1786 shall be provided.
- f) 1.6mm dia. G.I. wire shall be used for binding reinforcement.

Annexure OCS-3**FABRICATION AND ERECTION OF STEEL BRIDGE GIRDER****1. General**

Fabrication of all Steel Bridge Girders shall be performed within the plants and by fabricators having the experience, knowledge, trained manpower, quality controls, equipment and other facilities required to produce the steel work to desired quality. The plants where fabrication works are proposed to be performed shall be duly approved by RDSO for fabrication of OWG. The tenderer shall submit complete details of the plants along with his tender for the approval of the Engineer. Inspection and passing of fabricated elements/girder shall be done by the RDSO/Employer as per codal provisions and specifications.

Fabrication and erection of steel girder bridges shall be in accordance with IRS fabrication specifications (B1).

2. Material

- a. Steel: Mild steel for welded/riveted bridge girders subjected to railway loading shall conform to IS: 2062, Quality "B0" Grade Designation E250, fully killed and with normalizing/ normalizing rolling/ controlled rolling. Plates less than 12mm thick need not be with normalizing/ normalizing rolling/ controlled rolling.
- b. In case Rolled Steel Standard Sections conforming to IS:2062 Quality "B0" are not available in market, Engineer may permit use of steel conforming to IS:2062 Quality "BR" / "A" on case to case basis.
- c. Steel shall have smooth and uniform finish and shall be free from rolling defects such as cracks, flaws, seams, laps, imperfect edges etc. and other defects such as loose mill scale, rust, pitting, or other defects affecting its strength and durability.
- d. High Strength Friction Grip (HSFG) bolt assembly including Direct Tension Indicator (DTI) washers shall conform to EN: 14399 series.
- e. All the steel sections used in the fabrication must have mill test certificate clearly indicating the specification to which the steel conforms and whether steel is killed and normalized.
- f. The materials, on receipt, shall be carefully unloaded, examined for defects, checked, sorted, and stacked securely on a level bed, out of danger from flood or tide and out of contact with water or ground moisture. They will be supported on timber or concrete plinths so that they do not touch the ground.

3. Fabrication of steel work

- a. The records of fabrication shall be maintained in the registers as per the formats given in the Appendix I of IRS: B1-2001.
- b. The greatest accuracy shall be observed in the design, fabrication, and erection of every part of the work to ensure that all parts will fit accurately together on erection. Components of all the spans shall be fully interchangeable. Same jigs and assembly

fixtures duly approved shall be used. The tolerances in manufacture shall be in accordance with as shown in Appendix II of IRS: B1-2001.

- c. There should be level, finished concrete floor of sufficient dimensions in the fabrication yard, on which the fabricator will precisely set out the outline of the structure (to full scale) as per drawings for the purpose of preparing templates. Only steel tapes shall be used for all measurements, and they will be held tight and level on the floor while measuring or marking.
- d. Steel tapes used for marking out the work shall be calibrated at a temperature of 20° C.
- e. The templates throughout the work shall be of steel bushed.

i. Flattening and straightening

All steel materials, plates, bars and rolled sections shall have straight edges, flat surfaces and be free from twist. If necessary, they shall be cold straightened or flattened by pressure before being worked or assembled unless they are required to be of curvilinear form.

ii. Cutting of Steel

Cutting of steel for fabrication may be done by shearing, sawing, or by gas using mechanically controlled torch/torches. All flame cut edges shall be ground to obtain reasonably clean square and true edges. Plasma-arc cutting method may also be employed. This process offers less heat input causing less distortion.

iii. Making of Holes

Marking and drilling of holes in members shall preferably be done with the use of templates/jigs. All bolt holes in members built up by welding shall be drilled after welding.

Holes for turned bolts, should be 1mm under drilled in shop and should be reamed at site to suit the diameter of turned bolt. Jigs shall be periodically checked for tolerances from master plates.

iv. Welding

Welded construction work shall be carried out generally in accordance with the provisions of Indian Railway Standard Welded Bridge Code and subject to further specifications as given below:

- i) All welds shall be done by submerged arc welding process in shop. Site welding should not be undertaken except in special circumstances with the approval of the Engineer. Site welding should be confined to connections having low stresses, secondary members, bracings etc.
- ii) Suitable jigs and fixtures shall be used to avoid distortion during welding. Components which are mass fabricated in the shop should be proved in master templates.

- iii) Class and size of electrode for welding shall conform to IRS Specification M-28. For fabrication of steel bridge girder following class of electrode shall be used-

Class of Electrode as per IRS Specification No. M.28.66	Type of work to be welded	I.S. Specification No.	Code (as per IS:815- 66)
Class B2 (Moderately high ductility)	For welding of mild steel to IS:2062-1962 (Fusion welding quality) or equivalent, for service conditions where the weldment is rigid and subjected to relatively high dynamic stresses	814-63	M 110 to M 997-H, J, K or P.

Brand and make of electrode on approved list of M&C wing of RDSO should be used.

- a) No welding operator shall be employed on the work until he has, in the presence of the Engineer, passed the appropriate tests laid down in relevant codes.
- b) All main butt welds shall have complete penetration and shall comply with the requirements of IRS Welded Bridge Code. They shall be made between prepared fusion faces. Where possible they shall be welded from both sides. The ends of the welds shall have full throat thickness. This shall be obtained on all main welds by the use of extension pieces adequately secured on either side of the main plates. Additional metal remaining after the removal of the extension pieces shall be removed by machining, or by other approved means and the ends and surfaces of the welds shall be smoothly finished.
- c) In the fabrication of built-up assemblies all butt welds in the component parts shall be complete before the final assembly.
- d) A record of butt welds shall be kept to enable it to be identified with the welders responsible for the work but material shall not be marked by hard stamping for this purpose.

The welding techniques and sequence, quality, size of electrodes, voltage and current required shall be as prescribed by manufacturers of the material and welding equipment. The Contractor shall submit full details of welding procedure in proforma given at Appendix V of IRS: B1-2001 for approval of the Engineer.

v. Welding of Stud Shear Connectors:

- a) The welding of stud shear connectors shall be done by “DRAWN ARC STUD WELDING WITH CERAMIC FERRULE” technique. The shear stud and ceramic ferrules shall conform to type SD1/UF as per BS EN ISO 13918-2008.
- b) The stud and the surface to which studs are welded shall be free from scale, moisture, rust and other foreign material. The stud base shall not be painted, galvanized or cadmium plated prior to welding. Welding shall not be carried out when temperature is below 10 degrees Celsius or surface is wet or during periods of strong winds unless the work and the welder are adequately protected. The welds shall be visually free from cracks and shall be capable of developing at least the nominal ultimate strength of studs. The procedural trial for welding the stud shall be carried out when specified by the Engineer.

vi. Testing of Stud Shear Connectors:**a) Appearance Test**

- i) The weld to a shear stud connector should form a complete collar around the shank and free from cracks, excessive splashes of weld material, free from injurious laps, fins, seams, twist, bends or other injurious defects.
- ii) Weld material should have a ‘steel blue’ appearance.

b) Test to check the fixing of shear studs

- i) Ring Test: Involves striking the side of the head of stud with a 2 kg hammer. A ringing tone achieved after striking indicates good fusion whereas dull tone indicates a lack of fusion (BS 5400-6) All studs shall be checked by Ring test.
- ii) Bend Test: Test requires the head of a stud to be displaced laterally by approximate 25% of its height using 6kg hammer.
 - * The weld should then be checked for sign of cracking or lack of fusion.
 - * Stud should not be bent as back as this is likely to damage the weld.
 - * The testing rate should be 1 in 50 (BS 5400-6).

vii. Making of Joints

- a) Joints shall normally be made by filling not less than 50 per cent of holes with service bolts and barrel drifts in the ratio 4:1. Only barrel drifts shall be used in erection. Drifts may be used for drawing light members in position; but their use on heavy members shall be restricted to securing them in their correct position. Any error in the shop fabrication or

deformation resulting from handling and transportation which prevents proper assembling and fitting up of parts shall be reported immediately to the Engineer. No reaming shall be undertaken without the written authority of the Engineer.

- b) The erection of OWG shall be done in accordance with Appendix III of IRS: B1-2001. However, if the Contractor desires to adopt any other method of erection, they shall submit the scheme and obtain the approval of the Engineer. It shall be ensured that when in position, the girder has the camber as per drawing.

viii. High Strength Friction Grip (HSFG) bolting assembly

The HSFG bolting assembly shall conform to EN 14399 Series (High strength structural bolting assemblies for preloading):

- a) EN 14399-1:2015- General requirements.
- b) EN 14399-2:2015- Suitability for preloading.
- c) EN 14399-3:2015- System HR- Hexagonal bolt and nut assemblies.
- d) EN 14399-5:2015- Plain washers.
- e) EN 14399-6:2015- Plain chamfered washers.
- f) EN 14399-9:2009- Direct Tension Indicator for bolt and nut assembly.

HSFG bolting assemblies are very sensitive to differences in manufacture and lubrication. Therefore, complete HSFG bolting assembly (i.e. bolt, nut, washers & DTI) including galvanizing shall be procured from single manufacturer. Use of Direct Tension Indicator (DTI) washers shall be mandatory in the HSFG bolting assemblies.

Grade and size of bolts shall be as per the Drawings. The surface preparation, tightening procedures and other details for HSFG bolts shall be as per RDSO standard Drawing No. RDSO/B-11760/R1.

Table: Composition of high strength structural bolting assembly and its component marking

Type of bolting assembly		System HR	
General requirements		EN 14399-1	
Suitability for preloading		EN 14399-2 and, if any, additional testing specified in the product standard	
Bolt & Nut		EN 14399-3	
Marking	Bolt	HR8.8	HR10.9
	Nut	HR8 or HR10	HR10
Washers		EN 14399-5 ^a or EN 14399-6	
Marking		H or HR ^b	
Direct tension indicator and nut face washer or bolt face washer		EN 14399-9	
Marking	Direct Tension Indicator	H8	H10
	Nut Face Washer	HN	
	Bolt Face Washer	HB	
^a EN 14399-5 can only be used under the nut.			
^b At the choice of the manufacturer.			

The bolt length shall be chosen such that after tightening the following requirements are met for bolt end protrusion beyond the nut face and the thread length:

- i) the length of protrusion shall be at least the length of one thread pitch measured from the outer face of the nut to the end of bolt
- ii) at least four full threads (in addition to the thread run out) shall remain clear between the bearing surface of the nut and unthreaded part of the shank.

Holes for HSFG bolts- The holes shall be made by drilling only. The actual diameter of hole shall be 1.5 mm more than the bolt diameter for less than 25mm diameter bolts and 2mm more than nominal diameters of HSFG bolts for diameters 25mm and above.

Surface preparation of steel interface before providing HSFG bolts- Wherever property class 8.8 bolts are used these should be hot dip galvanized as per ISO: 10684(latest version). Property class 10.9 bolts should not be hot dip galvanized since this may cause hydrogen embrittlement. So these bolts should be coated with zinc flakes as per ISO: 10683 (latest version). However, depending on the site conditions, locations of these bolts in the structure and corrosion proneness, use of zinc flake spray coating as per ISO: 10683(latest version) can be adopted even for property class 8.8 bolts as well.

Installation of HSFG bolting assembly- Installation /tightening of preloaded bolting assemblies shall be carried out as per clause 8.3 & 8.5 of EN 1090-2 and clause 5.2 of EN 14399-9. The following steps shall be followed for tightening of bolts:

- i. The holes shall be brought in alignment by using drifts etc. such that bolt threads are not damaged/enlarged during insertion of bolts.
- ii. The members being joined shall be held in position by insertion of few HSFG bolts (tightened to first stage only i.e. snug tight condition).
- iii. After the alignment/geometry of members is verified to be correct as per drawings, balance bolts shall be inserted and tightened upto first stage of tightening. The drifts inserted as above shall also be replaced by HSFG bolts one by one.
- iv. After first stage of tightening, the joint shall be checked to see if the plies are in close contact and clearances are not exceeded.
- v. Second stage tightening shall be done with torque wrench. Bolts shall be tightened until indentation on the DTI indicate full tightening. In order to minimize loosening of already tight bolts, tightening in both the stages shall be done starting from the stiffest part to free edges.

- vi. 100% bolts shall be checked for proper tightening using feeler gauge of 0.4/0.25 mm.
- vii. Fully tensioned bolt, opened for any reason whatsoever, shall be rejected and removed from the site of work along with washers, nut and DTI.

4. Bearing and Expansion Gear

All bearings and expansion gears shall be procured from a reputed and experienced manufacturer qualified to undertake precision fabrication of this type and shall be approved by the Engineer.

5. Trial Shop erection

Trial shop erection shall be done in accordance with Cl.614 of IRBM.

6. Field erection

Field erection shall be done in accordance with Cl.616 of IRBM.

7. Erection in contractor's Works

The whole of the work shall be completely interchangeable. First span (of each type) shall be temporarily erected complete at the Contractor's Works for inspection by the Inspecting Officer to test the accuracy of the templates. Further spans or part span assemblies built from parts selected at random by the Inspecting Officer shall be erected from time to time to check the accuracy of the work as the Inspecting Officer may require.

8. Launching

Before taking up launching, the Contractor shall prepare and submit launching scheme along with design and methodology of launching including details of equipment proposed to be used for the approval of the Engineer.

a) Rail Flyovers (RFO)

After approval of the Engineer, launching scheme shall be got approved from Chief Bridge Engineer/Northern Railway. CRS application shall be prepared by the Contractor and submitted to the Commissioner of Railway Safety (CRS) through the

Engineer, HRIDC and CBE/NR. Work of launching shall be started only after receipt of sanction of CRS.

b) Road Under Bridges

After approval of the Engineer, launching scheme shall be got approved from concerned road authorities. Work of launching shall be started only after receipt of approval of concerned road authority.

During erection of plate/composite steel girder by crane special care shall be taken to support the girder by wooden blocks & temporary bracing to ensure stability against toppling till permanent bracings are provided.

9. Track work for OWG:

Track work for open web girder bridge on H-beam sleepers shall be done as per IRPWM, relevant RDSO drawings and codal provisions.

10. Camber

In order to eliminate secondary stresses in a span under loaded condition, the nominal length (i.e. the lengths which will give no camber) of member shall be increased or decreased by the amount shown on the camber diagram supplied by the Employer. Frequent checks shall be made of the camber of girders during erection and care taken to see that the camber as per drawing is obtained when the girder is completely assembled. When span is supported on ends and intermediate supports are removed the dead load camber shall be recorded and entered in bridge register. This will provide the reference to compare the camber checked during technical inspection to ascertain the loss of camber.

11. Test certificates & testing

All materials for the work shall pass Mechanical test, Charpy test, Chemical Analysis, etc. prescribed by the relevant IS specifications or such other equivalent specifications.

For all materials including HSFG bolts, the Contractor shall furnish copies of test certificates from the manufacturers including proof sheets, mill test certificates, etc. showing that the materials have been tested in accordance with the requirements of various specifications and codal provisions.

If any further testing of materials is required by Engineer in respect of these and other items, it shall be arranged for by the Contractor at a reputed laboratory/National test house as approved by Engineer. For this, nothing extra shall be payable.

Even satisfactory outcome of such tests or analysis shall in no way limit, dilute or interfere with the absolute right of the Engineer to reject the whole or part of such materials supplied, which in the judgement of the inspecting authority does not comply with the conditions of the contract. The decision of the Engineer in this regard shall be final, binding and conclusive for all purposes.

The Engineer shall be empowered, at his/her discretion to make or have made under the supervision, any of the tests specified in the specifications mentioned herein in addition to such other tests as he/she may consider necessary, at any time up to the completion of the contract and to such an extent as he/she may think necessary to determine the quality of all

materials used therein. In doing so, he/she shall be at liberty under any reasonable procedure, he/she may think fit to select, identify, have cut-off and take possession of test pieces from the material either before, during or after its being worked up into the finished product.

The Engineer shall also be empowered to call for a duly authenticated series of mechanical tests to be obtained from the maker for this materials used in the work and to accept the same in lieu of other tests to the extent he/she deems fit. The Contractor shall supply the material for the test pieces and shall also prepare the test pieces necessary.

The test shall be carried out by the Contractor, for which Contractor shall provide all facilities including supply of labour and plant. Engineer may at his/her discretion direct the Contractor to despatch such tests pieces as he/she may require to the National Test House or elsewhere as he/she may think fit for such testing purposes. The Engineer may at his/her discretion, check test results obtained at Contractor's work by independent tests at National Test House.

The Engineer shall at all times be empowered to examine and check the working of the Contractor's plant before and after using it. Should the Contractor's plant be found, in the Engineer's opinion, unreliable, he/she is empowered to cancel any tests already carried out in this contract and have these tests carried out at any National Test House or elsewhere, as he/she may think fit.

12. Fabrication drawings

The Contractor shall prepare detailed shop drawings including drawing office dispatch lists (DODL's) on the basis of design drawings supplied by Engineer in such size and in such details as may be specified by Engineer. The shop drawings shall be submitted to Engineer in triplicate.

No work of fabrication will be started without such approval being obtained. Contractor has to arrange the proof checking of the working fabrication drawings from the nominated Institution / Consultant. The cost will be borne by the Contractor.

13. Painting

- a. Fabricated steel work shall not be painted over except to the extent specified in para (b) until it has been inspected and passed by the Engineer or his representative and any defect, pointed out by him has been rectified.
- b. All surfaces which shall be in permanent contact and any others which will not be accessible for painting later on shall be cleaned thoroughly and given one coat of Zinc Chrome Red Oxide Priming to IS 2074 or other approved composition in the prescribed number of coats immediately prior to assembly.
- c. Steel girders (including all components) shall be provided with protective coating by metalizing with sprayed aluminum as given in the Appendix-VII of IRS: B1-2001, followed by painting as per painting schedule given below-
 - i. One coat of etch primer to IS:5666

- ii. One coat of zinc chrome primer to IS: 104 with the additional proviso that zinc chrome to be used in the manufacture of primer shall conform to type 2 of IS:51.
 - iii. Two coats of aluminum paint to IS: 2339 brushing or spraying as required. One coat shall be applied before the fabricated steel work leaves the shop. After the steel work is erected at site, the second finishing coat shall be applied after touching up the primer and the finishing coat if damaged in transit.
14. All third Party (RDSO/RITES/Any other nominated agency) Inspections charges for Open Web Girders and Composite Girders etc. shall be paid by the Employer.”

Annexure OCS-4**PRESTRESSING****1. GENERAL**

The work shall be carried out in accordance with the drawing and these specifications or as approved by the Engineer.

Concrete and un-tensioned steel for the construction of prestressed concrete members shall conform to the requirements of respective sections so far as the requirements of these Sections apply and are not specifically modified by requirements set forth herein.

Contractor shall ensure that different components of prestressing such as jacks, bearing plates, wedges, anchorages, strands, and HDPE ducts etc. are compatible to each other and the same shall be exchanged in between all the suppliers to ensure the same.

2. MATERIALS**a. Sheathing**

- i. The sheathing ducts shall be of the spiral corrugated type. Unless otherwise specified, the material shall be Cold Rolled Cold Annealed (CRCA) Mild Steel conforming to IS: 513 intended for mechanical treatment and surface refining but not for quench hardening or tempering.
- ii. The material shall normally be bright finished. However, where specified, as in case of use in aggressive environment, galvanized or lead-coated mild steel strips shall be used. The thickness of sheathing shall be as shown on the drawing, but shall nevertheless not be less than 0.3mm, 0.4mm and 0.5mm for sheathing ducts having internal diameter of 50mm, 75mm and 90 mm respectively. For larger diameter of ducts, thickness of sheathing shall be based on recommendations of prestressing system supplier or as directed by the Engineer.
- iii. For major projects, the sheathing ducts should preferably be manufactured at the project site utilising appropriate machines. With such an arrangement, long lengths of sheathing ducts may be used with consequent reduction in the number of joints and couplers. Where sheathing duct joints are unavoidable, such joints shall be made slurry tight by the use of corrugated threaded sleeve couplers which may be tightly screwed onto the outer side of the sheathing ducts.
- iv. The length of the coupler should not be less than 150mm but should be increased upto 200mm wherever practicable. The joints between the ends of the coupler and the duct shall be sealed with adhesive sealing tape to prevent penetration of cement slurry during concreting. The couplers of adjacent ducts should be staggered wherever practicable. As far as possible, couplers should not be located in curved zones. The corrugated sleeve couplers are being conveniently manufactured using the sheath making machine with the next higher size of die set.
- v. The internal diameter of the sheathing duct shall be in accordance with the recommendations of the system manufacturer and shall be about three times the area of the tendons. In case of 6T13, 12T13 and 19T13 sizes of tendons

comprising 12/13mm dia strands, the inner diameter of the sheathing shall not be less than 50mm, 75mm and 90mm respectively or those shown in the drawing, whichever is greater.

b. Anchorages

- i. Anchorages shall be procured from authorized manufacturers only. Anchorages shall conform to BS 4447. Test certificates from a laboratory fully equipped to carry out the tests shall be furnished to the Engineer. Such test certificates shall not be more than 12 months old at the time of making the proposal for adoption of a particular system for the project.
- ii. No damaged anchorages shall be used. Steel parts shall be protected from corrosion at all times. Threaded parts shall be protected by greased wrappings and tapped holes shall be protected by suitable plugs until used. The anchorage components shall be kept free from mortar and loose rust and any other deleterious coating.
- iii. Swages of prestressing strand and button heads of prestressing wire, where provided shall develop a strength of at least 95 per cent of the specified breaking load of the strand or wire as the case may be. Where swaging / button-heading is envisaged, the Contractor shall furnish details of his methodology and obtain approval of the Engineer, prior to his taking up the work.

c. Prestressing Steel

- i. 12.7mm nominal dia stress relieved low relaxation high tensile steel strand (CLASS-II) conforming to IS: 14268 with ultimate tensile strength 1861 N/mm² shall be used. Various test as recommended in IS: 14268 shall be conducted before transporting the lot to site. Apart from 1000 hrs relaxation test conducted by manufacturer, at least two such tests are required to be conducted by independent agency in the beginning of project.

d. Prestressing strands/Wires storage

- i. All high tensile steel for prestressing work shall be stored about 30cm above the ground in a suitably covered and closed space to protect it from dampness. It shall also be invariably wrapped in gunny cloth or tar paper or any other suitable materials, as per approval of Engineer. Even if it is to be stored in an area at the site for short time during transit it shall be suitably covered. Protection during storage and repacking or application of washable protective coating to the H.T. steel shall be given by the Contractor at no extra cost if the packing of H. T. Strand/wire during unloading and storage / handling in the stores gets damaged.
- ii. Stock piling of H. T. Steel on the work site shall not be allowed any time, especially before and during the monsoon.
- iii. The Engineer or his authorized representative shall always have an easy access to the store-yard for inspecting the H. T. Wire/strands/Bars and satisfying themselves regarding the condition thereof. Any modifications regarding storage suggested by the Engineer shall scrupulously be followed by the Contractor.

During monsoon days, H.T wires/strands shall be kept in reasonable airtight store, if required by the Engineer, at no extra cost.

e. Testing of Prestressing steel and Anchorages

- i. All materials specified for testing shall be furnished free of cost and shall be delivered in time for tests to be made well in advance of anticipated time of use.
- ii. All wire, strand or bars to be shipped to the site shall be assigned a lot number and tagged for identification purposes. Anchorage assemblies to be shipped shall be like-wise identified.
- iii. All samples submitted shall be representative of the lot to be furnished and in the case of wire or strand, shall be taken from the same master roll. The Contractor shall furnish samples of at least 5.0m length selected from each lot for testing. Also, two anchorage assemblies, complete with distribution plates of each size or types to be used, shall be furnished along with short lengths of strands as required.

3. WORKMANSHIP

a. Cleaning

- i. Tendons shall be free from loose rust, oil, grease, tar, paint, mud or any other deleterious substance.
- ii. Cleaning of the steel may be carried out by immersion in suitable solvent solutions, wire brushing or passing through a pressure box containing carborandum powder. However, the tendons shall not be brought to a polished condition.

b. Straightening

- i. High tensile steel wire and strand shall be supplied in coils of sufficiently large diameter such that tendons shall retain their physical properties and shall be straight as it unwinds from the coil. Tendons of any type that are damaged, kinked or bent shall not be used.
- ii. The packing of prestressing wire / strand shall be removed only just prior to making of cable for placement. Suitable stands shall be provided to facilitate uncoiling of wires / strands without damage to steel. Care shall be taken to avoid the possibility of steel coming into contact with the ground.

c. Positioning

i. Post-Tensioning

Prestressing tendons shall be accurately located and maintained in position, both vertically and horizontally, as per drawings.

Tendons shall be so arranged that they have a smooth profile without sudden bends or kinks.

The location of prestressed cables shall be such as to facilitate easy placement and vibration of concrete in between the tendons.

Sheathing shall be placed in correct position and profile by providing suitable ladders and spacers. Such ladders may be provided at intervals of approximately 1.0 m. Sheathing shall be tied rigidly with such ladders/spacer bars so that they do not get disturbed during concreting.

The method of supporting and fixing shall be such that profile of cables is not disturbed during vibrations, by pressure of wet concrete, by workmen or by construction traffic.

Each anchorage device shall be set square to the line of action of the corresponding prestressing tendon and shall be positioned securely to prevent movement during concreting.

The anchorage devices shall be cleaned to the satisfaction of the Engineer prior to the placing of concrete. After concreting, any mortar or concrete which adheres to bearing or wedging surfaces shall be removed immediately.

d. Cutting

- i. Cutting and trimming of wires or strands shall be done by suitable mechanical or flame cutters. When a flame cutter is used, care shall be taken to ensure that the flame does not come in contact with other stressed steel. The location of flame cutting of wire or strand shall be kept beyond 75mm of where the tendon will be gripped by the anchorage or jacks.
- ii. In post-tensioning the ends of prestressing steel projecting beyond the anchorages, shall be cut after the grout has set.

e. Protection of Prestressing steel

- i. Prestressing steel shall be continuously protected against corrosion, until grouted. The corrosion protector shall have no deleterious effect on the steel or concrete or on the bond strength of steel to concrete. Grouting shall conform to these specifications or as directed by the Engineer or specified in Contract Specifications.

f. Sheathing Joints and Couplings

- i. Joints in sheathing shall, if so, instructed be sealed with a heat shrink tape.
- ii. Special attention should be paid to its junction at the anchorage. It should tightly fit on the trumpet end of anchorage and the junction should be sealed, preferably, with heat shrink tape.
- iii. The heat shrink tape is supplied in the form of bandage rolls which can be used for all diameters of sheathing ducts. The bandage is coated on the underside with a heat sensitive adhesive so that after heating the bandage material shrinks on the sheathing duct and ensures formation of a leak-proof joint. The heating is affected by means of a soft gas flame.
- iv. The sheathing and all joints shall be watertight. Any temporary opening in the sheathing shall be satisfactorily plugged and all joints between sheathing and any other part of the prestressing system shall be effectively sealed to prevent

entry of mortar, dust, water or other deleterious matter. Sheathing shall be neatly fitted at joints without internal projection or reduction of diameter.

- v. Enlarged portions of the sheathing at couplings or anchorages shall be of sufficient length to provide for the extension of the tendons.

g. Grout Vents

- i. Grout vents of at least 20mm diameter shall be provided at both ends of the sheathing and at all valleys and crests along its length. Additional vents with plugs shall also be provided along the length of sheathing such that the spacings of consecutive vents do not exceed 20m. Each of the grout vents shall be provided with a plug or similar device capable of withstanding a pressure of 1.0MPa without the loss of water, air pressure or grout.

h. Anchorages

- i. All bearing surfaces of the anchorages shall be cleaned prior to concreting and tensioning. Anchor cones, blocks and plates shall be securely positioned and maintained during concreting such that the centre line of the duct passes axially through the anchorage assembly.
- ii. The anchorages shall be recessed from the concrete surface as per drawings.
- iii. After the prestressing operations are completed and prestressing strands are cut, the surface shall be painted with two coats of epoxy of suitable formulation having a dry film thickness of 80 microns per coat and entire recess shall be filled with concrete or non-shrink/pre-packaged mortar or epoxy concrete.

i. Handling and Storage

- i. Care shall be taken to avoid mechanically damaging, work-hardening or heating prestressing tendons while handling. All prestressing tendons shall be stored clear of the ground and protected from the weather, from splashes from any other materials, and from splashes from the cutting operation of an oxy-acetylene torch, or arc-welding processes in the vicinity.
- ii. In no circumstances shall prestressing tendons after manufacture be subjected to any welding operation, or 'on-site' heat treatment or metallic coating such as galvanizing. This does not preclude cutting as specified.
- iii. All wires, strands or bars stressed in one operation shall be taken, where possible, from the same parcel. Each cable shall be tagged with its number from which the coil numbers of the steel used can be identified. Cables shall not be kinked or twisted. Individual wires and strands for which extensions are to be measured shall be readily identifiable at each end of the member. No strand that has become unraveled shall be used.

j. Supervision

- i. All prestressing and grouting operations shall be undertaken by trained personnel only. A representative of supplier of the prestressing system shall be present during all tensioning and grouting operations and shall ensure, monitor and certify their correctness.

4. Tensioning Equipment

All tensioning equipment shall be procured from authorized manufacturers only and be approved by the Engineer prior to use. Where hydraulic jacks are used, they shall be power driven unless otherwise approved by the Engineer. The tensioning equipment shall satisfy the following requirements:

- a. The means of attachments of the prestressing steel to the jack or any other tensioning apparatus shall be safe and secure.
- b. Where two or more wires / strands constitute a tendon, a single multiple stressing jack shall be used which is capable of tensioning simultaneously all the wires / strands of the tendon. Suitable facilities for handling and attaching the multi-pull jack to the tendons shall be provided.
- c. The tensioning equipment shall be such that it can apply controlled total force gradually on the concrete without inducing dangerous secondary stresses in steel, anchorage or concrete; and
- d. Means shall be provided for direct measurement of the force by use of dynamo metres or pressure gauges fitted in the hydraulic system itself to determine the pressure in the jacks. Facilities shall also be provided for the linear measurement of the extension of prestressing steel to the nearest mm and of any slip of the gripping devices at transfer.
- e. Any indication in the loss of strength in tendons during the tensioning operation shall be brought to the attention of the Engineer. Any corrective measures which may be required in procedures and/or material shall be approved by the Engineer.
- f. When friction must be reduced, water soluble oil may be used subject to the approval of the Engineer. This oil may be flushed from the duct as soon as possible after stressing is completed by use of water pressure. These ducts shall be flushed again just prior to the grouting operations. Each time the ducts are flushed, they shall be immediately blown dry with oil-free air.

5. Testing by the Contractor

For the purpose of accurately determining the tendon elongations while stressing, the Contractor shall bench test two samples of each size and type of strand tendon to determine the modulus of elasticity prior to stressing the initial tendon. The bench should be at least 6metres long, with concrete anchorage blocks having a constant area end section of at least four times that of the anchorage assembly area. The tendon shall be straight and centered on the cross-sectional area of the bench. The test procedure shall consist of stressing the tendon at an anchor assembly with the dead end consisting of a load cell. The test specimen shall be tensioned to 80 percent of ultimate in 10 increments. For each increment, the gauge pressure, elongation and load cell force shall be recorded. The data shall be furnished to the Engineer.

The theoretical elongations shown on the post-tensioning working drawings shall be re-evaluated by the Contractor using the results of the tests and corrected as necessary. Revisions to the theoretical elongations shall be submitted to the Engineer for approval.

Apparatus and methods used to perform the tests shall be proposed by the Contractor and be subject to the approval of the Engineer. After the initial testing, five more tests shall be performed. These tests shall be spaced evenly throughout the duration of the Contract.

a. Post Tensioning Procedure

- i. Tensioning force shall be applied in gradual and steady steps and carried out in such a manner that the applied tensions and elongations can be measured at all times. The sequence of stressing applied tensions and elongations shall be in accordance with the approved drawing or as directed by the Engineer.
- ii. It shall be ensured that in no case, the load is applied to the concrete before it attains the strength specified on the drawing or as stipulated by the prestressing system supplier, whichever is more.
- iii. After prestressing steel has been anchored, the force exerted by the tensioning equipment shall be decreased gradually and steadily so as to avoid shock to the prestressing steel or anchorage.
- iv. The tensioning force applied to any tendon shall be determined by direct reading of the pressure gauges or dynamo metres and by comparison of the measured elongation with the calculated elongation. The calculated elongation shall be invariably adjusted with respect to the modulus of elasticity of steel for the particular lot as given by the manufacturer.
- v. The difference between calculated and observed tension and elongation during prestressing operations shall be regulated.
- vi. **Grouting of Prestressed Tendons:** Grouting shall conform to provisions in **Annexure D** of “IRS Concrete Bridge Code: 1997”. A record of grouting operations shall be maintained in a format given by Engineer.

6. Safety Precautions during Tensioning

These are applicable for both pre-tensioning and post tensioning operations.

- a. Care shall be taken during tensioning to ensure the safety of all persons in the vicinity.
- b. Jacks shall be secured in such a manner that they will be held in position, should they lose their grip on the tendons.
- c. No person shall be allowed to stand behind the jacks or close to the line of the tendons while tensioning is in progress.
- d. The operations of the jacks and the measurement of the elongation and associated operations shall be carried out in such a manner and from such a position that the safety of all concerned is ensured.
- e. A safety barrier shall be provided at both ends to prevent any tendon, which might become loose from recoiling unchecked.

- f. During actual tensioning operation, warning sign shall be displayed at both ends of the tendon. No person will stand behind in line with jacks while tendon / wire are being stressed.
- g. After prestressing, concrete shall neither be drilled nor any portion cut nor chipped away nor disturbed, without express approval of the Engineer.
- h. No welding shall be permitted on or near tendons nor shall any heat be applied to tendons. Any tendon which has been affected by welding, weld spatter or heat shall be rejected.

7. Transportation and Storage of Units

- a. Precast girders or elements shall be transported in an upright position. Points of support and the direction of reactions with respect to the girder shall approximately be the same during transportation, and storage as when the girder is placed in final position.
- b. When members are to be stacked, they shall be firmly supported at such bearing positions as will ensure that the stresses induced in them are always less than the permissible design stresses. Further, inclined side supports shall be provided at the ends and along the length of a precast girder to prevent lateral movements or instability.
- c. Care shall be taken during storage, hoisting and handling of the precast units to prevent their cracking or being otherwise damaged. Units worked or damaged by improper storing or handling or transport shall be replaced by the Contractor at his expense.

8. Tolerances

- a. Permissible tolerances for positional deviation of prestressing tendons shall be limited to the following:
 - i. Variation from the specified horizontal profile: 5 mm
 - ii. Variation from the specified vertical profile: 5 mm
 - iii. Variation from the specified position in member: 5 mm

Tender No. HORC/HRIDC/C-4/2022

Attachment 7 to Corrigendum No. 3

Section VII: Employer's Requirements

Section VII-7: General Electrical Services/R1

CHAPTER –1 SCOPE OF WORK	3
1.1 GENERAL	3
CHAPTER 2 — DESIGN AND PERFORMANCE REQUIREMENTS	8
2.1 GENERAL.....	8
CHAPTER –3 INSTALLATION AND CONSTRUCTION	11
3.1 REQUIREMENTS	11
CHAPTER – 4 TESTING AND COMMISSIONING	15
4.1 TESTING.....	15
4.2 TESTING CONDITIONS AND EQUIPMENT ACCEPTANCE.....	15
4.3 COMMISSIONING.....	19
CHAPTER – 5 MAINTENANCE AND TRAINING	20
5.1 INTRODUCTION.....	20
5.2 SUPERVISION AND PLANNING OF MAINTENANCE.....	21
5.3 TRAINING:	25
5.4 DEFECTS NOTIFICATION PERIOD (DNP)	28
5.5 SPARE MATERIAL.....	28
CHAPTER – 6 TECHNICAL SPECIFICATION	31
6.1 SUBSTATION (11/0.433) kV :-.....	31
6.2 11kV HT/LT COPPER CABLE: -.....	53
6.3 EMERGENCY POWER SUPPLY ARRANGEMENT (DG SETS OF 900/910 kVA CAPACITY).....	62
6.4 TUNNEL LIGHTING: -	68
6.5 PLUG SOCKETS & MAINTENANCE SOCKETS CABINET	79
6.6 UNINTERRUPTIBLE POWER SUPPLY SYSTEM (EMERGENCY POWER SUPPLY SYSTEM): -.....	80
6.7 ESCAPE ROUTE ORIENTATION SIGN AND FIRE EXTINGUISHER GLOW SIGNAGE	88
6.8 SITC OF STAINLESS STEEL CABLE TRAY (LADDER AND PERFORATED TYPE) : -.....	90
6.9 ELECTRIFICATION OF SUB-STATION AND OTHER SERVICE BUILDING/ROOMS WITH ALLIED FACILITIES	91
6.10 NEW CONNECTION OF ELECTRIC POWER SUPPLY (3 PHASE, 11 KV) FOR BOTH SUBSTATIONS OF HORC TUNNEL AND ALL ASSOCIATED WORKS:	91
6.11 DESIGN, SUPPLY, INSTALLATION, TESTING AND COMMISSIONING OF EARTHING SYSTEM BY USING OF: -.....	92
6.12 SUPPLY & INSTALLATION OF EARTHING AND POTENTIAL EQUALIZATION SYSTEM FOR INSIDE TUNNEL WITH CROSSINGS.....	93

CHAPTER –1 SCOPE OF WORK**1.1 GENERAL**

A general description of the broad scope of work, relating to works covered in this Tender under Schedule A, is given below. It shall, however, be clearly understood that the description is for the purpose of general guidance only and is not exhaustive. For complete appreciation of the Scope, the specifications, drawings and other relevant paragraphs of the Tender documents shall be referred to.

1.1.1 ITEMS OF WORK

The jobs **Tunnel** to be carried out by the Contractor under this contract comprises of but not limited to the following: -

ITEM . No.	Description of Work	Total Qty
1	Design, Supply, Erection, Testing & Commissioning of (11/ 0.433) kV Sub-station complete in all respect along with all protection system including 11kVA GIS HT Panel Board, (2x2000) kVA Dry Type Transformers (02 Nos transformer for each substation, Sub-station-1 (SS-1) at Centre of Tunnel and Sub-station-2 (SS-2) at Sonapat end of Tunnel), 3 ways 11 kV Ring Main Unit (RMU) comprising of 2 Nos load break switch, Battery Charger, APFC Panel, LT Distribution Panel, other necessary switchgears, Complete Earthing system & all associated works as per specification. GIS panels shall be operated and monitored through SCADA. This includes construction of sub-stations building complete in all respects as per specification and drawing.	01 Job
2.	Design, Supply, Testing & Commissioning of 11 kV HT/LT fire survival Copper cable (Power and Control) Network of adequate sizes including laying of cables in Air/HDPE pipe/DWC Pipe/ Trench of size 0.5 mts wide x 1.2 mts deep/ stainless steel cable tray/ cable ladders/ Stainless steel conduit on wall inside/outside of the tunnel as per site requirement, specification and standard. 1.Main HT Supply (Incoming supply) for SS-1 and SS-2 = 3x120 Sqmm Cu cable. 2. HT supply between SS-1 and SS-2 for Ring main system = 3x95 Sqmm Cu cable. 3. LT Distribution Network from SS-1 and SS-2 = 4x50,4x25 Sqmm and other size of copper cable as per specification. Note: - EPC Contractor shall ensure laying of spare cables of same size for each feeder as per Railway Board/RDSO Guidelines.	01 Job
3	Supply, Erection, Testing & Commissioning of 900 kVA / 910 kVA Advantage prime rating diesel generating set (11000 volts Alternator) along with powder coated acoustic enclosures at SS-1 and SS-2 suitable for outdoor application including AMF panel, <i>NGR & NIS Panel</i> Auto synchronizing panels, silencers, Earthing system, all civil work & associated arrangement as per CPCB norms and as per specification.	01 Job

ITEM . No.	Description of Work	Total Qty
4	Design, Supply, Erection, Testing and Commissioning of tunnel lighting system and its associated works by using of 4x25/4x16/4x10, 4x6/4x4 sqmm copper cable, energy efficient 20 watt LED fixtures, Lighting DB's, Lighting Panel, Junction Box with complete wiring of multi core 1.5/2.5/4/6 sqmm Cu conductor cable laying in stainless steel conduit of dia 12.5/25mm, necessary switch gears and surge protection equipment complete in all respect as per site requirement, standard and specification.	01 Job
5	Design, Supply, Installation, Testing and commissioning of Maintenance Power socket (1 Phase- 16/20 Amp, 3Pin and 3 Phase- 16/20 Amp, 5Pin) system including MCB's, all accessories and Maintenance DB's with IP 65 protection complete in all respect as per site requirement, standard and specification.	01 Job
6	Design, Supply, Installation, Testing & Commissioning of Emergency power supply system including online UPS 20 kVA (minimum) capacity with Sealed Maintenance Free Heavy duty lead acid Batteries for 120 minutes backup along with UPS lighting DB's and other accessories, powder coated steel racks for placing batteries, interconnecting Copper PVC sleeved bus bars complete in all respect as per site requirement specification and standard. UPS Power Supply to be designed through DG set for providing Level-I illumination in the tunnel as per specification. One UPS at SS-1 and one UPS at SS-2 .	01 Job
7	Design, Supply, Installation, Testing and Commissioning of Programmable Illuminated Escape Route Orientation sign board, Programmable non illuminated Escape Route Orientation sign board controlled by SCADA and Fire Extinguisher glow signage board, other required Signage board, as per decision of Engineer and Visibility Sensors at adequate distance controlled & monitored through SCADA, complete in all respect as per site requirement, standard and specification.	01 Job
8	Supply, Installation, Testing and Commissioning of stainless steel cable Trays of size 150x50x2mm thickness ladder and Perforated type as per specification made of material no. 1.4404, throughout the tunnel, for HT/LT and lighting etc. Cu. Cable, wall mounted on hot dip galvanized heavy duty steel structure, continuously connected including horizontal and vertical bends, reducers, tees, coupling plate and <i>high-grade stainless-steel</i> anchor fasteners of material no. 1.4401 complete in all respect and as per site requirement	01 Job
9	Electrification of Sub-station and other service Building/Rooms with allied facilities including LED luminaries (Indore & 150-watt flood light fitting with all accessories, 1.5-ton capacity split Ac 5-star rating for control room, 150 ltrs water cooler and all other electrical accessories as per site requirement specification and guide line issued by RDSO/Railway Board.	01 Job

ITEM . No.	Description of Work	Total Qty
10	<p><i>Reliable Electrical Power Supply (3 phase, 11 kV) for both sub-stations (Separate feeder circuit for each substation) of tunnel and associated works including all liaison work from State DISCOM.. The Contractor shall assess the load requirement and connected load of each substation. after load calculation for each tunnel and obtain approval of the Engineer for the purpose of getting new connection for each substation. The cost Include (for each substation) copper cable laying/Overhead Line with H-pole from DISCOM substation to HRIDC HT panel, Metering arrangement, protection, earthing connection of DISCOM end and connection at HRIDC substation including payment for application fees, charges etc. for 2000kVA load of each substation Necessary clearance from statutory authorities.</i></p>	01 Job
11	Design, Supply, Installation, Testing and Commissioning of Earthing System of following type: -	
11 (a)	Supply, Installation, Testing and Commissioning of Earthing system with 3-meter-long, 50 mm dia, G.I. pipe class 'B' earth electrode, adding of charcoal or coke and salt, providing masonry enclosure. (<i>Brick with class designation not less than 7.5 and cement plaster 1:4</i>) and cover plate with lifting arrangement etc. including connections with 8 SWG G.I wire from earth electrode as per specification.	
11 (b)	Supply, Installation, Testing and Commissioning of Maintenance Free Earthing (chemical Earthing) as per specification	
11 (c)	Supply, Installation, testing & Commissioning of Copper Bonded Steel Earth Rod of 3-meter length, 17.2 mm dia with Exothermically welded busbar along with 50 kg Earth Enhancement Compound in each pit. pit covers made up of Poly Plastic and SITC of 10 mm Copper Clad Steel Round Conductor laid at 600mm below the ground, as per specification, requirement and code of practice.	01 Job
11 (d)	Supply, Installation, <i>Testing & commissioning</i> of Earth Grid for 11/0.433 KV Substations. It shall have a Copper Bonded steel rod & conductor of diameter 17.2 mm / 3 meters length. An earth rod shall have an earth enhancement compound 50 kg per pit. All the joints shall be exothermically welded. Dedicated riser of 50x6 & 25 x 6 mm copper coated steel strip shall be provided for Neutral & Body respectively with RCC Chambers. With Copper MET's shall be provided <i>Poly carbonate</i> (PC) enclosure. An Isolation spark gap shall be provided for equipotential bonding as per IEC 62561-3 & as per requirement and specification.	
12	Design, Supply, Installation, Testing and Commissioning of Earthing and Potential equalization system for Inside throughout the tunnel with crossings by following material: -	
12 (a)	Providing, excavating & laying of stainless steel main potential equalization 150 sq mm <i>conductor</i> to be laid inside the tunnel on both walls of the tunnel. It shall be available in a drum roll of minimum 1000	01 Job

ITEM . No.	Description of Work	Total Qty
	meters. Inclusive exothermic welded joints at the required intervals for connections to other elements of the earthing network and straight through joints.	
12 (b)	Providing & laying of stainless steel main potential equalization 25 sq. mm <i>conductor</i> for all required earth connections to MET to be laid at every crossing to interconnect busbar to the other equipment for equipotential bonding along with all required fixing arrangements. <i>One end shall be connected to 150 sq mm conductor and other to any equipment as required.</i>	
12(c)	Providing & fixing of Isolation Spark Gaps for Equipotential Bonding as per IEC 62561- 3	
12 (d)	Supply, Design & Fixing of Stainless steel potential equalization Bus bar (<i>MET</i>) of size 500x50x6 mm with 8 holes for <i>electrical equipment and 400X25X3 for S&T equipment</i> provided on both sides of the tunnel at every 200 m along with all accessories to connected to earth grid with stainless steel main potential equalization 150 sq mm It shall be enclosed in an enclosure Poly cabinet (PC) box with transparent front cover and fixed to the wall with insulated fire resistant supports.	
12(e)	<i>Supply, Design & Fixing of two independent earth grids on each side of both the Tunnels (8 nos). Each earth grid shall have a copper bonded steel rod & conductor of diameter 17.2 mm/3 meters length. An earth rod shall have an earth enhancement compound 50 kg per pit. All the joints shall be exothermally welded. Dedicated riser of 50X6 & 25x6 mm copper coated steel strip shall be provided for OHE, Electrical equipment, Neutral & Body respectively with RCC chambers with copper METs shall be provided PC enclosure. An isolation spark gap shall be provided for equipotential bonding as per IEC 62561-3 & as per requirement and specification. Dedicated riser of 50X6 mm copper coated steel strip shall be provided for Telecom equipment in both tunnels separately. Contractor shall design the system as per relevant IEC, DIN, EN, IS standards.</i>	01 Job
13	<i>Supply of spares and tools & Tackles and measuring equipment.</i>	01 Job
14	<i>Routine Maintenance of Electrical items and Manning of both substations round the clock</i>	01 Job

NOTE: -

- 1) All the quantity, type, rating and size of equipment /material (Transformer, DG and HT/LT Panels etc.) in above table *are* indicative *and minimum rating* only. It may *increase* as per EPC contractor design, various guidelines & standard issued by RDSO/Railway Board and site condition.

- 2) Deleted .
- 3) Deleted.
- 4) Contractor shall arrange all RDSO drawings, documents, specification from RDSO at their own cost.
- 5) No mild steel materials shall be used anywhere in the electrical system in project.
- 6) The zinc coating steel item shall be as per RDSO specification no. ETI/OHE/13(4/84) Latest or IS specification. Mild steel shall be hot dip galvanised to 610 g/sqm of zinc.
- 7) Unless otherwise specified in the tender document, all bolts, studs, Nuts, Washers, and pins etc shall be of stainless steel or high-tension copper alloy for current carrying conductors for all other applications, galvanised steel shall be used.
- 8) The cable upto 16 sqmm size shall be copper conductor XLPE insulate only. Cables above 16 sqmm size may be of copper or aluminium as mentioned in the tender document or as submitted by contractor and approved by Engineer.
- 9) Cables/Wiring shall be laid down in metallic/rigid fire resistant PVC conduits. PVC conduits shall be used in concealed wiring only.
- 10) During cable laying and on the bends radius of the cable shall be maintained as per IS standard.
- 11) All Electrical appliances/equipment viz LED lights, Fans, Exhaust Fan, Air conditioner, Water cooler, Transformers, shall carry highest star rating for energy efficiency as prescribed by Bureau of Energy Efficiency (BEE) as applicable.
- 12) The scope of work shall be read in conjunction with detailed specifications mentioned in tender document.

XXXXXX

CHAPTER 2 — DESIGN AND PERFORMANCE REQUIREMENTS

2.1 General

2.1.1 The design, supply, installation, testing and commissioning of General Services work including Power supply system and construction of sub-station buildings etc. shall meet the design and performance requirements within the design environments specified in this PS.

2.1.2 Design Environment

- i. Adequate Margin shall be built in Design, particularly to take care of Climate Conditions/Operating Environment. Wherever the equipment is installed in open at the surface level or inside service buildings at surface level, the same shall be designed for working in the tropical conditions existing here and the ambient temperature and humidity levels pertaining to HORC Project area.
- ii. Tunnel walls may be wet and seepage water will normally be present in the invert. The system design shall, therefore, take into consideration the effect of seepage and continue to operate in such wet and humid conditions.
- iii. *Contractor shall interface with all agencies during design and execution stage of the project.*

2.2 Basic Design Philosophy and Requirements

2.2.1 Proven Design

- i. The Contractor shall develop the design based on specification and on proven and reliable Engineering Practices. The design details shall be submitted with technical data and calculations to the Engineer for review.
- ii. The contractor shall submit drawings in such a form as the Engineer will require them for approval, copies as required of all drawings, diagrams and details of all equipment in part or in whole. The contractor shall make any drawings available to the Engineer at all reasonable times. Wiring diagrams and other drawings as the Engineer deems shall not be finally settled until satisfactory installation and testing has been made, this shall be approved in principle.
- iii. The contractor shall submit a schematic block diagram of the equipment showing the manner, in which the functional requirements of this specification shall work together. The contractor shall submit a schedule including details of numbering, categories and drawing registers / indexes for the production, submission and approval during the period of the contract of drawings and also of any information, required for the Engineer in connection with the design of the contract works.
- iv. This schedule shall be suited to the requirements of manufacture, delivery and installation of the contract works to meet the requirements of the contract and shall allow reasonable time (approx. 8 weeks) for study and approval by the Engineer of all drawings, calculations and graphics submitted (and, as necessary, resubmitted) by the contractor. *Contractor shall undertake work only after obtaining No Objection for the work from Engineer.*
- v. No approval by the Engineer of any drawing shall relieve the contractor of any of his obligations of liabilities under the contract or of his responsibility for ensuring that the work is satisfactory done and that all operational requirements shall be met.
- vi. The contractor shall provide final drawings without undue delay, and in any case within twelve weeks of the award of the contract, these drawings shall include dimensions, capacity of equipment and complete power supply & lightning arrangements of tunnels with all associated items.

2.2.2 The design philosophy should meet the following criteria:

- a) Application of state-of-the-art Technology
- b) Service proven design
- c) Design life 20 years. (*Individual components may have different design life.*)
- d) Minimum life cycle cost
- e) Low maintenance cost
- f) Use of interchangeable, modular components
- g) Extensive and prominent labelling of parts, cables and wires
- h) High reliability
- i) Low energy loss
- j) System safety
- k) Adequate redundancy in system
- l) Fire and smoke protection
- m) Use of fire retardant materials and fire survivals cables
- n) Environment friendly
- o) Adherence to operational performance requirements
- p) Maximum utilization of indigenous materials and skills, subject to quality conformity.

Adequate margin shall be built into the design particularly to take care of the higher ambient temperatures, dusty conditions, and high seasonal humidity, etc. prevailing in HORC Project area.

2.3 AS-BUILT DRAWINGS

Preparation of the as-built drawings shall be part of these specifications. As-built drawings will be Final Design Drawings of the project showing the actual work done. The contractor shall provide the as-built drawings in one original and one reproducible negative produced from the original, with the names of the signature authorities of the Engineer and the contractor. After they are signed for approval, prints shall be taken from the signed original of each drawing. Also, *Hard Disc Drive (Min 1 TB size)* with all as-built drawings shall be handed over to the Engineer. Together with the as-built drawings, the contractor shall provide reduced size (e.g. A3 size) booklets of the as-built drawings as per the Engineer requirement.

All details, dimensions, texts, etc., on the reduced size drawings shall be clearly recognizable and readable. The contractor shall complete and obtain the Engineer's approval on the as-built drawings and make the final submission of the as-built drawings together with the A3 size booklets latest within three months following the date of the Certificate of Completion. All costs associated with the provisions mentioned above shall be deemed to be included in the contract price.

As-built drawings shall cover in general (but not limited to):

- a) **For mechanical equipment:**
 - i. Construction drawings,
 - ii. Instruction drawings,
 - iii. Functional block diagrams with set-point range of process parameters depicted

thereon.

b) For electrical installation:

- i. Installation drawings with circuit numbers and exact type-assignment of all installed equipment.
- ii. Distribution diagrams with circuit numbers,
- iii. Fault analysis and protection co-ordination settings the of protection system,
- iv. Power consumption,
- v. Precise type numbering
- vi. Earthing systems

c) For distribution panels:

- i. Construction drawings,
- ii. Circuit drawings as operating diagrams,
- iii. Additional current flow-charts where required,
- iv. Accurate lists of any installed equipment with precise description of this equipment,
- v. Adjustment tolerances of circuit-breakers, switches, etc.

d) For equipment:

- i. Construction drawings,
- ii. Circuit diagrams,
- iii. Functional block diagrams with set-point range of process parameters depicted thereon,
- iv. List of quantities with detailed break-down of the bill of materials comprising the equipment.

e) For cabling:

- i. Diagrams with dimensions, type of cables and power requirements with regular cross- section area and measured cable values shall be used for these diagrams.

2.4 System Requirements:

2.4.1 Conformity with Governing Specifications and other Statutory Requirements: -

The work shall be carried out in accordance with the following governing specifications and other statutory rules:

- i. CEA Regulations 2010
- ii. Indian Electricity Act 2003 with latest amendments.
- iii. Central Safety regulations, 2010
- iv. Regulations laid down by Chief Electrical Inspector to the Government.
- v. Regulations laid down by EIG Indian Railways.
- vi. Rules and Regulations prescribed by local authorities as applicable.
- vii. Relevant, Indian Standards, IEC Standards, CENELEC, British Standards, Tunnel draft Manual of Indian Railways (as applicable) and other National/ International standards as applicable.
- viii. The Contractor shall furnish information asked for by a statutory body (e.g., Government of India, Ministry of Railways, Commissioner of Railway Safety, Government of Haryana etc.) in particular format as directed by Engineer. Any documents, studies, test reports, compliances required for getting safety clearances from any authority shall be submitted by the contractor

XXXXXX

CHAPTER –3 INSTALLATION AND CONSTRUCTION

3.1 REQUIREMENTS

3.1.1.General Requirements

- i. The Contractor shall comply with all Enactments in executing the Works, including but not limited to all statutory provisions on occupational health and safety.
- ii. The Contractor shall co-ordinate with Other Contractors in the execution of the Works.
- iii. The Contractor shall also co-operate with all Relevant Authorities in the execution of the Works.
- iv. The installation of all equipment shall be undertaken at all times by suitably trained and competent employees of the Contractor, to the satisfaction of the Engineer.
- v. Only appropriate tools, plant, equipment and vehicles shall be used.
- vi. Installation of all equipment shall be in accordance with the Construction and Installation Plan described in the drawing/plans as approved by Engineer before commissioning of work.
- vii. Installation of all equipment shall conform to the best industry practices.
- viii. Precautions shall be undertaken to ensure the safety of personnel and equipment for all installation works.
- ix. The Contractor shall, prior to starting any installation and construction work, identify any possible hazards, and implement measures of eliminating and/or controlling such potential hazards, in line with safe working practices.
- x. The Contractor shall ensure that all areas of work are sufficiently illuminated for the works to be undertaken and that a safe system of work is employed for all activities.
- xi. The Contractor shall operate a robust system for the control of persons entering or working upon the site.
- xii. The Contractor shall co-operate, always, with the Engineer and Other Contractors to ensure that the Site is protected from unauthorised admission, either wilfully or otherwise.
- xiii. The Contractor shall make due provision for the safe access and egress to the Site of Works for its staff and subcontractors.
- xiv. This access shall be maintained such that it is free of all hazards and is in a safe condition throughout the duration of the Works.
- xv. **The EPC contractor shall set up at least one main store/ depot for receiving and storing materials & other equipment at his own cost.**

3.1.2 Specific Requirements

The installation and construction work pertaining to this Contract shall include, but not be limited to the following: -

- i. Finalisation of the Construction and Installation Programme provided by EPC contractor and duly approved by Engineer.
- ii. Survey on Site and review the technical requirements shown in this Specification and the Engineer's Drawings (if any).
- iii. Production of the calculation sheets and installation drawings for Site installation.

- iv. Production of specific site designs and drawings based on typical designs and drawings supplied.
- v. Installation in accordance with the finalised installation drawings.
- vi. Co-ordination with Other Contractors.
- vii. Submission of the installation reports and records.
- viii. Testing and commissioning, as per finalised protocol and programme.

3.2 Construction and Installation Plan

The Contractor shall undertake installation work in stages as shown in the detailed installation programme. Installation, testing and commissioning of later stages shall not impact revenue operation of earlier stages.

As a minimum, the detailed Construction and Installation Plan shall include but not be limited to all the activities, installation details and methods of all activities, equipment and tools to be used for installation, safety issues, supervision, temporary land occupation needed and the vehicles to be used for installation.

3.2.1 Material Handling

To facilitate handling of equipment during installation and maintenance thereafter, the Contractor shall closely co-ordinate and interface with other contractors travelling hoists and unloading jib cranes for sub-stations. The entire material handling plan for movement of bulky item such as Transformers, Panels, DG sets, and cables etc. shall be carefully planned. Crane of adequate capacity with a jib of requisite length will be arranged by the EPC Contractor at his own cost. Road crane for handling heavy materials at the contractor's depot for loading and unloading of material will be arranged by the contractor who will also arrange his own crew for its operation and maintenance. All charges including pay and allowances of the crew and all running expenditure will be borne by the contractor.

3.3 Site Supervision/ Deployment of Technical Staff: -

3.3.1 The Contractor shall set up a Site supervision system, which shall be part of the overall safety, system assurance and quality management system.

- i. The Contractor shall provide sufficient number of experienced Engineer, Supervisors and skilled workers to ensure progress and quality of the work at Site and in the Contractor's workshops (if any), are maintained to the satisfaction of the Engineer. The minimum number of Engineers required to be deployed is shown in table below: -

S.N	Post	Minimum Eligibility	Minimum Requirements in nos.
1	Sr. Engineer (overall in charge of all type of General Services work)	Graduate in Electrical Engineering with 7 or more- year experience in Electrical and E&M System.	1
2	Electrical Engineer (Site Engineer)	Graduate in Electrical Engineering with 5 or more-year experience in HT & LT works. Or Diploma in Electrical Engineer with 7 or more years experience in HT & LT works.	1

S.N	Post	Minimum Eligibility	Minimum Requirements in nos.
3	E&M Engineer (Site Engineer)	Graduate in Electrical /Mechanical Engineering with 2 or more-year experience in E&M system. Or Diploma in Electrical/ Mechanical Engineer with 3 or more-year experience in E&M system.	1

- ii. The contractor shall submit to the Engineer, not later than 60 days from the date of award of contract, the organization chart showing following key positions, and CV's of the incumbents and the brief job descriptions. The Engineer shall issue Notice of "No-objection" or otherwise for the appointment of "key positions" within stipulated working days of such submission.
- iii. The performance of personnel shall be under observation by Engineer. In case the performance of any personnel is not up to the mark, as decided by Engineer, . contractor shall be responsible for replacement of such personnel.
- iv. In case the contractor fails to employ the technical staff as aforesaid to the satisfaction of the Engineer-in-charge, the recovery shall be as mentioned below per each calendar month or part thereof of default.

Sl. No.	Post	Amount to be recovered per person per each calendar month or part thereof of default. (Rs)
1	Sr. Engineer	1.0 Lakhs
2	Electrical Engineer	50,000 /-
3	E&M Engineer	40,000/-

- v. Contractor is to abide by the provisions of Payment of Wages act & Minimum wage act.
- vi. The Contractor's supervision system shall be responsible not only for the supervision of the concerned system installation but also for the supervision of the installation of the primary fixing system, earth mats and systems, etc. The supervisors shall work on a full-time basis during the entire installation process.
- vii. The Contractor shall maintain a set of drawings at each system which accurately reflect the current status of field changes. The Contractor shall obtain letter of no objection from the Engineer for any such changes. The Contractor shall prepare final drawings showing the as built configuration. These drawings shall be developed in a logical format to facilitate routine system maintenance and troubleshooting. All drawings and details shall be endorsed by the Contractor.
- viii. The Engineer reserves the right to undertake, at any time, checks on the proficiency of the Contractors staff, licensing and all associated documentation. If any of the Contractors

staff be found incompetent or unlicensed he shall be removed from the site until their Competency has been established.

3.4 Workmanship

All the installation shall be carried out according to the instructions shown in these specifications and Drawings (as approved).

All assemblies of equipment and their components and parts shall be completely interchangeable if they are of similar type

The style and procedure of the workmanship shall be consistent throughout the Works.

Unless otherwise specified, the Engineer shall decide the final colours for all paint work and other finishes to be applied to any part of the Works.

All parts, which are subject to, wear or damage by dust, shall be completely enclosed in dust proof housings.

3.4.1 Installation of Cables

The Contractor shall co-ordinate with the Civil Contractors wherever necessary, for the installation of cables in cable galleries, trenches, ducts, trays, risers and other locations.

The cable system shall, during installation, be fully protected from mechanical damage and be generally accessible at all points for inspection along its entire route. Suitable cable *route* markers shall be provided for covered cables upon completion of installation *Cable Route Marker size 200X150X3 mm thick GI plate for HT/LT electrical underground cables. The plate shall be provided with 250X50X6 mm GI flat whose one portion shall be welded to the route marker plate and another antiskid end shall be embedded suitably in 150X150X 150 mm M-20 grade concrete and concrete block shall be minimum 100 mm below the ground..*

The maximum pulling force of any cable during installation shall not exceed the design force of cables.

All cables shall be installed in the formed cable trenches, shafts, hangers, trays and brackets. The minimum recommended bending radius of the cables shall be adhered to during installation.

All materials used for termination, jointing and installation of cables in confined spaces shall have flame retardant, low smoke, halogen free characteristics.

XXXXXXX

CHAPTER – 4 TESTING AND COMMISSIONING**4.1 TESTING**

This Chapter describes the testing & commissioning related to the Various General Services works in conformity with the requirements of RDSO/Railway Board Standards and standard Railway practices.

Testing constitutes an essential obligation to satisfy the Railway System.

4.2 Testing Conditions and Equipment Acceptance

The Contractor Shall carry out all the tests and checks required guaranteeing the Engineer of the good construction and the satisfactory operation of all power supply installation.

Also, the contractor shall co-ordinate & arranges testing equipment etc. required for testing facilities.

The various high, medium and low voltage equipment will be subjected to all the tests required under equipment test sheets, (lists are not exhaustive) as per the relevant IEC or other standards mentioned in the technical specification of each equipment or otherwise.

It is reminded that the contractor is totally entrusted with full responsibility of assembly and installation of all pieces of equipment mentioned in this specification, with supplying the maintenance equipment and the special tooling which shall be delivered as soon as equipment installation will be completed and with the various duties he is bound to regarding witnessing of tests at commissioning and supervision after energising.

4.2.1 In-plant testing: -

In plant *Type Test* , routine tests and factory acceptance test:

- i. Type tests are tests performed on one or two of an equipment series
- ii. Routine test are tests performed on each equipment
- iii. Factory acceptance tests are tests on a sample size as per standards.
- iv. These tests will enable checking the quality of the equipment and its compliance with the specifications.
- v. Following equipment, if desired by the Engineer shall be tested at third-party (duly approved by the Engineer)/ RITES during Factory Acceptance Test.:
 1. DG sets
 2. Transformer of any capacity
 3. Switch gears
 4. Different size of cables (LT/HT)
 5. LED light fittings
 6. Different types of HT/LT panels, RMU and APFC panel etc.
 7. Earthing material

Once the equipment will have passed the in-plant acceptance tests, it shall be delivered and installed under the contractor responsibility.

Concerning some type tests, test certificates issued by recognised agencies will be able to be

supplied if the contractor cannot carry out these tests himself and if the test certificates are related to a similar equipment of same capacity and design. *These type test certification shall not be more than 7 years old from the date of issue of LOA (Letter Of Acceptance)*

The final factory tests will be carried out on the fully assembled equipment as specified. Thereafter, if required and permitted by the technical features of the equipment, the equipment may be dis-assembled for transportation purposes. The dis-assembly should not, however, cause any deterioration of the technical performance of the equipment.

These tests will be carried out by the contractor, under his responsibility and in the presence of the Engineer and of the consulting Engineer. The cost of Factory Inspection/Site Inspection/Lab Test/Documentations will be borne by contractor.

Each of these tests will be subjected to a certificate. Provisional acceptance will be granted only after execution of the both sets of tests.

NOTE: For type tests, the contractor can provide test reports performed according to the corresponding IEC standard, on similar equipment of same capacity and design.

4.2.2 Third Party Tests

- i. During execution stage Engineer may conduct the Test on any type of equipment from third party independent lab at its own cost, to ensure the quality of material supplies. If any of the samples fail in the test, the cost of the Test along with the complete replacement of whole lot shall be borne by the Contractor.
- ii. If contractor represents, two random samples from the failed Lot shall be collected by the contractor in the presence of Engineer duly sealing the samples and send to two different NABL accredited labs (as approved by Engineer) for conducting all those tests, which were conducted on the failed sample. Cost of the testing including the collection of sample and transportation of sample will be borne by the contractor.
- iii. If both the samples pass all the Tests, the Lot will be deemed as accepted by HRIDC, but in the case of failure of any of the samples collected by the contractor, complete Lot will be deemed as rejected and contractor will replace the whole Lot.
- iv. The delay, if any for the procurement of the material due to failure, shall be considered as non-compliance and applicable penalty shall be imposed on the contractor.

4.2.3 System Acceptance Tests

At least six weeks in advance of any particular site testing, the contractor shall submit details of tests and details for the teste equipment the proposes to use for that testing to the Engineer for his approval.

All tests for statutory requirements and insurances including arrangements for such tests, inspections by Authorized bodies, persons or insurers, as necessary and the provision of certificates in the prescribed and approved forms necessary to enable plant and equipment to be put into service, shall be made by the contractor.

If each section of plant is installed, commissioning tests for each section shall be carried out on site. At least six weeks in advance of any particular site testing, the contractor shall submit details of tests and details for the test equipment he proposes to use for that testing to the Engineer for his approval. As installation proceeds, the insulation resistance of cables shall be checked and recorded.

The identification of the cores shall be confirmed from end to end of each cable end, in the case of communication, alarm- and control-cabling, from end to end of each circuit. Tests on cables shall be completed and accepted by the Engineer before the testing of the associated equipment starts.

All tests for statutory requirements and insurances including arrangements for such tests, inspections by authorized bodies, persons or insurers, as necessary and the provision of certificates in the prescribed and approved forms necessary to enable plant and equipment to be put into service, shall be made by the contractor.

4.2.3.1 On-site commissioning tests being subject of acceptance by the Engineer shall include:

- a) All equipment, cabling, distribution etc. is electrically and mechanically safe.
- b) All interlocks, isolators and door and cover securing mechanisms shall be properly fitted and adjusted.
- c) All exposed metal work is properly bonded and grounded and that all connections and points required to be grounded for a safe and satisfactory operation shall be properly grounded in accordance with the manufacturer's requirements.
- d) All cables, cores and terminations shall be secure, properly fitted and correctly identified and coloured.
- e) All phases, polarities, neutral and common connections shall be correctly switched / connected as required, so that the power is correctly available at all points and that the voltage and frequency at all equipment is correct and in accordance with the requirements for correct work.
- f) All supplies shall be provided with proper fuse or otherwise protected, to give successfully discrimination and safe disconnection under fault conditions.
- g) All contacts shall be properly aligned / adjusted and not subject to excessive wear or corrosion.
- h) Batteries shall be correctly installed, connected and fitted and checked that the battery chargers are working correctly.
- i) The insulation-resistance of all cabling and equipment shall not be less than specified.
- j) During the commissioning of major item like GIS panel, Transformer, DG sets etc. the contractor shall arrange expert Engineer of OEM of such item at respective sites. The expenditure for charges for the same including transport, lodging, shall be borne by the contractor at no extra cost.
- k) All instruments and meters shall be energized with correct polarity and working properly.
- l) All fault indications and alarms shall be working correctly.
- m) In addition to all operational tests, required for a successful hand-over, the operation of all interlocks, sequences and protections which are not utilized in normal operations shall be subject of acceptance by the engineer.
- n) The on-site commissioning tests shall be conducted under the supervision of the engineer.

- 4.2.3.2** The final acceptance tests shall begin after all on-site commissioning tests have been successfully completed and all defects detected during those tests have been rectified / corrected, which is accepted by the Engineer. The tests shall include full operation tests on the works as a whole and selected technical tests on some or all of the equipment.
- 4.2.3.3** On completion of the site acceptance tests, the contractor shall forward the test results certified by him to the Engineer. When the Engineer has received the results and deems that the plant has successfully passed the tests, Engineer will write to the contractor to that effect. During the site acceptance tests the Engineer shall inform the contractor of minor faults detected and which of these minor faults shall be corrected before the beginning of the tests on completion.
- 4.2.3.4**
- a) Type test shall be performed by the contractor and shall be witnessed by Employer's personnel/representative and/ or the Engineer.*
 - b) Factory Acceptance Test including stage inspection, if required, shall be performed by the contractor, and shall be witnessed by Employer's personnel/representative and/ or the Engineer.*
 - c) The standard equipment which are serial, or bulk manufactured (branded, the manufacturer's type test certificate may be acceptable, subject to review by Engineer.*
 - d) All material used for permanent work shall be as per specification and GTP (Guaranteed Technical Particulars).*
 - e) Manufacturing and testing of various equipment and fitting shall be as per approved technical requirement GTP etc.*
 - g) The contractor shall submit the engineer a request for a "Notice of No Objection" to supply for manufacture item along with manufacture test certificate, Inspection Certificate prior to shipping/Transporting.*

4.2.4 TRIAL OPERATION

The trial operation shall occur with full responsibility of the contractor. The trial operation shall take place after finishing the tests on completion. For starting the trial operation, it is required, that all tests on completion are finished positive for the entire installation and shall occur within 21 days.

The trial operation shall show the evidence of a fully functional operation of the tunnel and that security is given during operation. Therefore, the trial operation shall occur without significant malfunctions. The contractor shall test different operation cases during the trial operation (e.g. loss of different equipment etc.).

The contractor shall make organizational measurements during the trial operation, so that malfunctions can be rectified as soon as possible (within max. 2 days).

The results of the different tests during trial operation shall be shown in a protocol. This protocol shall be signed by the contractor and the Engineer.

The cost of all consumables including water, electricity, fuel, lube oil etc. shall be borne by contractor.

4.2.5 Energization: -

The Contractor shall prepare operation safety rules and procedures for the review of the Engineer before Energization.

The Contractor shall carry out all necessary checks to ensure safe Energization.

All power equipment shall be subject to inspection by inspectors from the Electrical Inspectorate of Engineer before Energization. The Contractor shall ensure all Engineer requirements are met. Contractor shall be responsible for reliable operation of all Electrical equipment.

4.3 COMMISSIONING**4.3.1 General**

The Commissioning description, based on the following frame, will have to be defined by the contractor and submitted to the Engineer.

Once the contractor has completed the above tests, and the various pieces of equipment installation, the assignment should include:

- i. Putting into service tests
- ii. After energising

The Engineer will be empowered to ask for any additional testing as deem necessary. The contractor will have to supply the testing installations and measuring apparatuses required to this effect in accordance with the stipulations, provisional acceptance will then take place, followed by final acceptance at the end of the guarantee time.

4.3.1.1 Putting into Service Tests

It should be performed at this stage the tests verifying that the different equipment is acting correctly when energised.

4.3.1.2 Integrated Testing and Commissioning

The general testing having shown proper operation, an overall integrated test of the installations, should be performed, after the first 15 days of operation, during which the various actuation and operation situation (putting into service, normal actuation, failure tripping) will be simulated.

XXXXXX

CHAPTER – 5 MAINTENANCE AND TRAINING

5.1 INTRODUCTION

This Chapter describes the maintenance philosophy and training of maintenance staff for Electrical system considering RDSO/ Railway board standards and Railway practices.

The Contractor shall provide comprehensive training and documentation to the Engineer *and Employer's* staff in accordance with the requirement of this chapter and the chapter of General Specifications.

This training shall enable all the installations, to be operated and maintained in the most efficient and safe manner, to achieve the maximum reliability and economy required by such System.

Note: - All type of Routine, Preventative and Schedule Maintenance work will be carried out at regular intervals, based on latest SMI's/ Instructions/Guidelines issued by RDSO/Railway Board and equipment manufacturers' recommendations.

5.1.1 Maintenance Management

The management of the maintenance process entails defining various levels of responsibility and enabling them to implement the strategic orientations defined by the directing authority:

- i. By defining their respective missions,
- ii. By setting objectives for each person,
- iii. By translating these objectives into action plans,
- iv. By implementing the means required to carry out action plans,
- v. By diagnosing the causes of any deviation from the set objectives,
- vi. By taking corrective measures concerning the action plans or the objectives.

This management process requires a global approach and helps to improve the performance of the maintenance work of different components with quality, on time and at low cost. It must be implemented at three levels:

- i. At the level of human resources and management in the context of the scheduling of work, the allocation of human resources and the training of personnel.
- ii. At the skills level to ensure quality, safety and suitable working conditions.
- iii. At an economic and financial level to ensure responsible management of production, spare parts, purchasing and miscellaneous costs.

The quality of this management depends on the capability of those entrusted with operation and maintenance responsibilities:

- i. To exploit the results of management within their field of responsibility.
- ii. To react in the event of any deviation from the action plans defined with a view to achieving the set objectives.

Within the context of this approach, the management control function ensures timely advice to be given to those with operational and maintenance responsibility:

- i. By placing at their disposal, the tools and information required for piloting and diagnosis.
- ii. By participating in carrying out this diagnosis.
- iii. By participating in the task of defining the objectives to be achieved.

In conclusion, the process of maintenance management must incorporate two major components:

- i. the management of human resources and the study of the most suitable means of achieving the set objectives.
- ii. This is one of the first guidelines of maintenance organisation in the various relevant centres.

5.1.2 Determining Requirements in Terms of Facilities and Tools

The achievement of the objectives assigned to the maintenance division about quality, safety and regularity for the lowest possible overall cost requires the implementation of a number of resources which must be perfectly tailored to the requirements.

The facilities and tools are part and parcel of the resources placed at the disposal of the maintenance division to achieve the set objectives.

Owing to the cost of these facilities, the number of maintenance centres to be equipped and the necessity of keeping the maintenance actions consistent and uniform, the main choices of facilities and tools are integral part of the System maintenance policy and program.

When determining these requirements, in-depth knowledge in the dedicated maintenance plan is needed while taking due account of the experience acquired in similar fixed installation which has been in service for several years.

5.2 SUPERVISION AND PLANNING OF MAINTENANCE

5.2.1 General

The following outlines the Engineer's maintenance strategy, various levels of maintenance, the Maintenance Management System and the arrangement for maintenance.

The Contractor shall make use of all relevant information to provide supervision of maintenance.

5.2.2 Engineer's Maintenance Strategy

According to the maintenance strategy, all equipment and infrastructure supplied for the 'Project' must be such as to ensure for minimum or no maintenance. Maintenance activities required must be capable of being performed with little or no impact on the train service. In addition, the maintenance work systems shall ensure safety of personnel and equipment.

The Contractor shall ensure that to supervise maintenance during the DNP (Defects Notification Period) personnel are always available with the relevant skills and level of competence.

The Contractor, upon noticing any defects, deficiency in quality and quantity of spares and materials shall without delay, arrange for alternative source of supply and submit his proposal to the Engineer for review.

5.2.3 Planned Maintenance

Routine preventative maintenance will be carried out at regular intervals based on condition, reliability, usage, and service history, SMI 's issued by Railway Board/ RDSO and equipment manufacturers' recommendations. The Operating and Maintenance Manual shall describe the different levels of planned maintenance.

5.2.4 Supervisory Staff

The Contractor shall provide supervisory Maintenance staff who are expert in all the different levels of fault finding, maintenance and repair of the various relevant systems supplied under the Contract:

- i. Electrical system
- ii. Switch gear/power supply arrangement
- iii. Other works

5.2.5 Maintenance and Maintenance activity

Maintenance Management System (MMS) and Maintenance Arrangement:

The contractor will develop maintenance management system and get it approved from Engineer for schedule maintenance of Electrical system.

All type of maintenance activity of all Works will be conducted by the contractor staff under his supervision, till the **expiry of a period of 01 (One) year from taking over**. All type of Routine, preventative and schedule maintenance work will be carried out at regular intervals based on SMI's/ Instructions issued by RDSO/Railway Board and equipment manufacturers' recommendations. Under this, all the labour laws would be applicable, and contractor has to submit all the records (EPF/ESI and other certificates) to Engineer.

5.2.6 Competency of Personnel and Deployment of Maintenance staff *during DNP*:

During the One-year Maintenance, the Contractor shall support the Engineer with sufficient trained and competent personnel Such persons shall have their generic competence established and must demonstrate their specific competence and knowledge in the particular systems, environment and procedures. The competency certificates of such maintenance staff shall be issued by Engineer.

The detail of deploying staff is as under:

S. No	Personnel	Qualification	Total work experience (in year)	Required No of staff	Remark
1	Maintenance In-charge	Graduate Degree in Electrical Engineering	Min. 08 Years of working experience of any Electrical/E&M/Ventilation. Project.	01	Overall in charge of all type of Electrical work
2	Maintenance Engineer (Electrical and E&M)	Degree/ Diploma in Electrical Engineering	Min. 3 years for degree & 5 Years for diploma holder of working experience of any E&M/Electrical General	01	Required as Site Engineer for all type of Electrical General services

S. No	Personnel	Qualification	Total work experience (in year)	Required No of staff	Remark
			services project.		work
3	Maintenance Engineer (Electrical and E&M)	Degree/ Diploma in Electrical Engineering	Min. 2 years for degree & 3 Years for diploma holder of working experience of E&M Project or E&M maintenance activity.	03	Required for Manning of 11 kV Substations/Control Room for round the clock (one person in each shift)
4	Skilled Staff for Manning Purpose	ITI in Electrical Trade	Min. 04 Years of working experience on any E&M /General power supply arrangement project	03	Required for Manning of 11 kV Substations/ control Room for round the clock(one person in each shift)
5	Skilled Staff for Maintenance activity	ITI in Electrical Trade	Min. 04 Years of working experience on any E&M /General power supply arrangement project	04	Required to perform day to day maintenance activity

The Contractor shall provide evidence of specific competence and knowledge, which shall include:

- i. Assessment and certified training in particular software applications and operations.
- ii. Receiving or in receipt of sufficient and current exposure to the area of work that the holder is licensed for.

In the event of a failure, the Contractor shall undertake the management and investigation necessary to identify and rectify the cause.

If the Engineer, during the DNP requires further investigations at other Sites throughout the system, the Engineer will formally request the Contractor to undertake such investigations.

5.2.7 Maintenance requirements

I. Testing and Re-commissioning of System and Equipment

In the event of a failure requiring modifications to the System, the Contractor shall undertake any testing and re-commissioning required.

Any such modification shall be submitted for Engineer review.

II. Temporary Alterations to Restore Service

The Contractor shall undertake any temporary modifications necessary to maintain service.

Any such modification shall be submitted for Engineer review.

III. Discrepancies between Installation and Design Records

Should the Contractor discover inconsistencies between the maintenance drawings and documentation and the installed equipment, the Contractor shall correct all such errors within two weeks.

IV. Communications

The Contractor shall ensure that adequate communication facilities are provided to its staff during the DNP and maintenance period as per approval of Engineer.

V. Location of Staff

The Contractor shall be responsible for locating staff such that the Contractor meets its contractual obligations and as per approval of Engineer.

VI. Maintenance Regimes

The Contractor shall provide documented maintenance regimes to be followed by the Engineer upon substantial completion of various components of the work until the end of the DNP.

The Contractor shall produce a maintenance regime for the equipment that shall comprise two constituent parts, corrective and routine/preventative maintenance.

Routine/preventative maintenance shall be non-intrusive to the day-to-day operation of the train service and be capable of being pre-planned in advance of the work.

Corrective maintenance shall be available 24 hours per day, able to respond to all foreseeable circumstances.

The maintenance regime shall cover all parts and equipment of the system designed, installed and commissioned by the Contractor.

The Contractor shall take into account the requirements of the operations and maintenance when determining and proposing its maintenance regime.

VII. Scope and Hours of Coverage

The regime and structure of corrective maintenance shall be robust in design.

The Contractor shall provide full 24 hour On-Call coverage and shall be such that initial response and rectification of failure are in accordance with the following:

- i. Assistance to first level and corrective maintenance within 30 minutes, upon request of first line maintainer.
- ii. All elements of preventative maintenance shall be carried out and completed during non-traffic hours without interrupting train services.

VIII. Routine and Corrective Maintenance Procedures

Routine and corrective maintenance procedures shall be supplied for all equipment. The format shall be as follows:

- i. Uniform format and layout irrespective of equipment supplier.
- ii. Colour coding for each activity.
- iii. Cross referenced to the Operation and Maintenance Manuals.
- iv. Document control information.

IX. Maintenance Manuals

The Contractor particulars of operating parameters, tools for dismantling and testing, methods of assembly and disassembly, tolerances, repair techniques and all other information necessary to set up a repair and servicing programme as per satisfaction of Engineer.

The Contractor shall *prepare maintenance manual and* provide documentation for all hardware and software for computer systems and other associated electronic equipment to meet the following requirements.

Such documents shall include but not be limited to:

- i. manufacturers' documentation supplied as standard with the equipment.
- ii. hardware configuration with details of expansion capabilities and options.
- iii. programme loading instructions, including runtime environment configuration.
- iv. programme listing including comprehensive 'comment statements' in hard copy and soft format for source code, compilers and development tools necessary to modify and recompile software.
- v. flow charts, data flow diagrams and state diagrams as appropriate.
- vi. description of software modules including purpose, linkage with other modules, error routines and any special considerations.
- vii. memory maps for both internal and peripheral memory showing description of all programmes, data files, overlay areas, memory available for expansion and the like;
- viii. loading and operating instructions for diagnostic programmes and specifically developed debugging tools; and
- ix. Programming manuals relevant to operating systems, languages, development tools, etc.

The manual shall also include inspection/overhaul procedure and periodicity of various inspection/overhaul schedules in detail including the tools, special tools/plants, and facilities required.

5.3 TRAINING:

During the contract period, the contractor shall provide training manuals, as well as onsite training and training courses to ensure that the Engineer and employer's staff associated with this project may acquire full knowledge and appreciation / understanding of all aspects of the design, day to day operation, breakdown and routine maintenance and fault diagnosis of the power supply, the surveillance and control equipment as well as the belonging hard- and software.

The contractor shall train the Engineer and Employer's personnel about all equipment in theoretical and practical way. Also, the maintenance staff shall be trained. The Engineer will nominate members of his staff, who are attending the training courses.

The contractor shall nominate qualified instructors. It shall be essential that prior approval of the Engineer is obtained for the instructor and the instructor's qualifications in each case.

The contractor shall provide all relevant and necessary facilities which are needed for complete and effective staff training (such as video, TV, slide- and film-projectors and others) and venue. The contractor shall provide all facilities including accommodation, transport and catering of all trainees. Within three months after the signing of the contract, the contractor shall submit a detailed syllabus for the training courses for approval by the Engineer.

5.3.1 General Requirements

The Contractor keeping the above aspect in view shall provide comprehensive training to the Engineer's staff in accordance with the requirements contained in this Particular specification and general specification. The training courses and/or sessions shall include system performance requirements and all major equipment and works designed, by the Contractor.

The specific objectives of each course, training facilities to be used, the qualification and experience of the training instructors and the assessment criteria shall be developed by the Contractor and submitted to the Engineer for review at least three months before any course is conducted.

The Contractor shall provide full-time on-Site management and co-ordination of the entire training programme to ensure the continuity of classes, and proper distribution of training materials, and be responsible for interfacing with the instructors.

The training courses shall be delivered to all relevant Engineer's staff, including instructors, operation and maintenance Engineering staff.

5.3.2 Mock-Up for Training

The Contractor shall install mock-up equipment for system and any such facility(s) considered necessary for the training of Engineer's staff in the training school.

The training mock-up shall include but not limited to the following: -

- i. Clear Cut Section drawings / photographs of various power supply equipment's such as Circuit Breakers, HT/LT panel, Power supply arraignment, Current Transformers and Potential Transformers.
- ii. Cut Section drawings / photographs of HT/LT cables.
- iii. Cut Section drawings / photographs of Gas Insulated Switchgear and other types of panels.
- iv. Clear photographs of transformers, their windings, bushings etc.
- v. Samples of various item used in substations.
- vi. Clear drawings and photographs of Control panel, protection schemes, earthing and complete power supply arrangement system.

The Contractor shall submit full details of the training span and other mock up equipment, photographs etc. including proposed training activities and objectives.

5.3.3 Training of Engineer's Training Instructors (ETI)

The objective of the training is to enable the Engineer's Training Instructors to be competent to deliver future training courses for other employees of the Engineer.

The Contractor shall provide training to the Engineer's Training Instructors on the various Systems. Aspects covered shall include, but not be limited to, the following:

- i. Configuration of the entire System, including interface with the DHBVNL supply system at the feeding points;

- ii. Feature and functional principles of the entire System;
- iii. System design aspects including but not limited to design standards, design criteria and parameters, short-circuit and other calculations, insulation and protection co-ordination;
- iv. Details of major equipment and material including but not limited to voltage and current transformers, Electrical fittings, assemblies and protection relays, and cables of different types and their joints used in the system;
- v. System operation and maintenance management and procedures;
- vi. Earthing arrangement, covering safety aspects of touch and step potential, safety to personnel, passengers and outsiders;

5.3.4 Operations Staff Training

The objective of the training is to enable the Engineer's operations staff to be familiar with the Systems, with focus on the operational aspects under normal and emergency conditions.

The training shall also enable the trainee to acquire full capability for identification, trouble shooting and rectification of faults in the specified duration. After classroom training which includes mock ups of equipment, the staff shall be trained in actual operation.

5.3.4.1 Maintenance Staff Training

The objective of the training is to enable the Engineer's maintenance staff and Engineering staff to be familiar with the Systems focus on the maintenance aspects of the System including but not limited to the following: -

- i. Full understanding of all the equipment, sub-systems and system, their function, maintenance and overall requirements.
- ii. Procedures to be followed for unscheduled maintenance and repair.
- iii. Identification of failed components and sub-systems in electronic equipment by use of special test kit as necessary.
- iv. Modification in the software to extend or modify the control, monitoring and protection functions.

5.3.4.2 Training Requirements

Man weeks of contractor's Training Instructors for training Engineer's maintenance personnel in India.

S. No	Training	Man-Weeks
1	HT/LT panels, Transformer, Circuit Breakers, DG set, Switchgear and cables	2
2	Other General services Equipment/Electrical wiring <i>biz</i> MCCB, MCB, Fuses, Cable laying, conduiting, wiring, Busbars, UPS, Battery, Lighting, High Mast Lighting etc.	2
3	Electrical safety & Earthing system	1

5.4 Defects Notification Period (DNP)

The Contractor shall be responsible for all the Defects and deficiencies, till the expiry of a **period of 01 (One) year**. The Contractor shall repair or rectify all Defects and deficiencies observed by the Authority Engineer during the Defects Notification Period within time period as may be determined by the Engineer in accordance with Good Industry Practice. *All materials required/ rectification during DNP shall be arranged by contractor. Contractor shall submit the list of DNP spares with types and quantity which contractor intends to hold during DNP, at least six months before start of DNP, to Engineer for review.*

5.4.1 Warranty Certificates from OEM:

- i. All Original Warranty Certificates of OEMs of all Electrical system or equipment including contract spare, Commissioning spare, DNP spares and Special tools & Test and Measuring equipment shall be valid for three years or as specified in RDSO Specification of the equipment whichever is later and registered in the name of Engineer. These warranty certificates received from the OEMs should be passed on to Engineer before final Taking over.
- ii. Validity of period of Warranty Certificates shall start from date of Commissioning.
- iii. Original invoice shall also be submitted with the OEM warranty certificates in a booklet form before Commissioning.
- iv. Warranty period and defect liability support shall start from the date of Commissioning.

5.5 Spare material

5.5.1 General

The Contractor shall supply spare parts, special tools and test equipment in accordance with the requirements and as decided by Engineer.

5.5.2 Contract Spares

The Contractor shall supply quantity of spare parts with minimum quantity as given below in Table. The price of below quantity of spare should be quoted in the item provided in Sub - Cost Center E2 –Inventory/spares items. The evaluation of the tender shall be done considering this price of spares. Upon approval of the Engineer the procurement of spares should be done by contractor.

Sr. No	Item	Unit	Quantity
1	Copper cable of all sizes	Meter	5% of the total cable laid subject to a minimum of 500 mtrs of each type.
2	All other Copper wires	Meter	5% of the total wire used / laid subject to a minimum of 100 meter of each type.
3	Maintenance free batteries	Nos.	10% of each type installed. Subject to minimum of one.
4	UPS	Nos	2 (20 kVA minimum)
5	Battery Charger	Nos	1 No

6	MCB, surge protection device, fuses & other switch gears of HT/LT panel	Nos	15% of each type installed. Subject to minimum of one.
7	All other interconnecting cables/connectors not included above	Nos	10% of each type installed. Subject to minimum of 2 Nos
8	All type of LED fittings and other Electrical equipment	Nos	10% of each type installed. Subject to minimum of 10 Nos
9	<i>Straight through joint 11 kV</i>	<i>Nos</i>	<i>4</i>

Note: - Spare shall be procured only after the approval from the Engineer. The Items of spares given are indicative and final items shall be approved by the Engineer. The equipment/kits supplied should be as per latest specifications/models and should be compatible with the existing system being installed in this contract. Approval for the specifications should be taken from engineer before placement of the order.

5.5.3 Long Lead Times

The Contractor shall identify the lead times for all spare parts. Parts with long lead times shall be identified in the spares list.

5.5.4 Routine Change

In the event that any item of the supply requires to be routinely changed or calibrated regardless of whether it appears in the spares list or not, it shall be identified to the Engineer together with the routine change interval.

5.5.5 Shelf Life

In the event that any of the spares identified have a particular life or storage requirement, this shall be made known to the Engineer with the submission of the spares list, including the necessary action for disposal or storage.

5.5.6 Special Tools, Testing and Diagnostic Equipment and Measuring Instruments

The Contractor shall supply adequate quantity of special tools, testing and diagnostic equipment and measuring instruments in accordance in order to carry out all the functions necessary for operation and maintenance of the entire system and also considering the requirements as described in the Operation and Maintenance Manuals. The special tools, testing and diagnostic equipment and measuring instruments shall also include apart from the other necessary items.

The contractor should ensure that the special tools and test equipment provided are compatible with equipment supplied under this Contract. The details of item are as under:

<i>Sr. No</i>	<i>Item</i>	<i>Unit</i>	<i>Quantity</i>
<i>1</i>	<i>Cable fault locator</i>	<i>No</i>	<i>1</i>
<i>2</i>	<i>Digital Earth Tester</i>	<i>Nos</i>	<i>2</i>
<i>3</i>	<i>Earth Leakage detector 1000 Volt.</i>	<i>Nos</i>	<i>1</i>
<i>4</i>	<i>Digital Insulation Tester 2.5-5 kV</i>	<i>Nos</i>	<i>2</i>

5	Digital Insulation Tester 0-1000V	Nos	2
6	Vernier Caliper	No	1
7	Aluminum Ladder (5 m)	Nos	2
8	Wire cutter 12"	Nos	6
9	Non-Metallic Hammer	Nos	2
10	Digital Multimeter	Nos	4
11	Electrical tool kit	Nos	4
12	Safety PPE (Jacket and Helmet)	Nos	10
13	Portable grinder electrically operated	Nos	2
14	D shackle set (1", 3/4", 5/8' -one each)	set	5
15	Single sleeve pulley block (100 mm wheel dia & 15 mm groove)	set	5

5.5.7 Coding and Tagging of Spare Parts and Special Tools and Test Equipment

- i. All Spares/Spare Parts and Special Tools and Test Equipment to be delivered to the Engineer shall each carry a tag suitably marked, bar-coded (as directed by the Engineer) and numbered.
- ii. The numbers on the tags shall correspond with those on the coding system developed by the Contractor for all Electrical components, parts and equipment.

XXXX

CHAPTER – 6 TECHNICAL SPECIFICATION

6.1 SUBSTATION (11/0.433) kV :-

Indicative conceptual layout plan of civil structure/building of Sub-stations attached in Section VII-8: Tender Drawings and Documents. The contractor has to construct Sub-Station building accordingly.

The electrical sub-station consists of following electrical equipment but not limit to:-

6.1.1 11 kV GIS HT Panel Board :-

This specification covers design, manufacture, assembly, testing before supply, inspection, packing and delivery of metal clad partitioned, SF6 gas insulated switchgear confirming to IEC-62271-200. The GIS (Gas Insulated Switchgear) type switchgears shall be complete with all the accessories and auxiliary equipment's required for their satisfactory operation such as switchboard panels for line bays, bus coupler/bus section bays etc. shall be fitted with vacuum circuit breakers, three position disconnect and earthing switches, voltage transformers, current transformers, metering instruments, protection relays, cable terminal ends/plugs for incoming & outgoing cable feeders etc.

6.1.1.1 OBJECTIVE & TOLERANCES:-

It is intended to have:

- a. Enhanced safety, availability, maintainability and reliability
- b. Maintenance free switchgear
- c. Reduction in space requirement with low environmental footprint
- d. Integrated remote control and monitoring-SCADA compatible.

Tolerances: -

Tolerances on all the dimensions shall be in accordance with provisions made in the relevant IS/IEC standards and in these specifications. otherwise the same will be governed by good engineering practice in conformity with required quality of the product.

6.1.1.2 SERVICE CONDITIONS:

A. System particulars:

- | | | |
|---|-----|----------------|
| a) Nominal system voltage | ... | 11 kV |
| b) Corresponding highest system voltage | ... | 12 kV |
| c) Frequency | ... | 50 Hz \pm 3% |
| d) Number of phases | ... | 3 |
| e) Neutral earthing grounded | ... | Solidly |
| f) Short Current Rating | ... | 25 kA |

B. Auxiliary supplies available through UPS are as follows

- | | | |
|-----------------|------|--|
| a) A. C. Supply | ---- | 433/240 volts with \pm 10% variation |
| b) Frequency | ---- | 50 Hz with \pm 3% variation |

6.1.1.3 SWITCH GEAR PANEL: -

- a) The Gas insulated Metal clad switchgear shall be complete with all the accessories for efficient and trouble-free operation. The equipment offered shall be safe, reliable, high availability, easily maintainable and compact to install. The workmanship shall be of high order. The circuit breaker, switches and protective device etc. shall be latest design so as to ensure rapid and efficient interruption of fault current low arc energy, small arcing time and freedom from fire hazards.
- b) The GIS shall be designed, manufactured and tested in accordance with the best international engineering practices under strict quality control to meet the requirement stipulated in the technical specification. Adequate safety margin with respect to thermal, mechanical, dielectric stress, dynamic short circuit fault and insulation coordination is to be maintained during design, selection of raw material, manufacturing process etc. so that the GIS provides long life with least maintenance. The complete switchgear shall be designed to manage the risks associated with it such that there shall not be any safety hazard to the employees in normal service and during inspection and maintenance.
- c) The workmanship shall be of the highest quality and shall conform to the latest modern practices for the manufacture of high technology machinery and electrical switchgear.
- d) The switchgear panel shall be fully arc proof, free standing, floor mounted, fully compartmentalized, metal enclosed construction complying requirements of IEC 62271- 200. Each circuit shall have a separate vertical panel with required compartments for circuit breaker, cable termination, main bus-bars, three-position switch and auxiliary control devices.
- e) The SF6 gas insulated metal enclosed switchgear shall be totally safe against inadvertent touch (by human/animal) of any of its constituent live parts.
- f) The design should be such that all parts subjected to wear and tear are easily accessible for maintenance purposes. The Service Class Continuity of Switchgears shall be LSC-2 (as per IEC 62271-200), LSC 2B-PM (as per IEC 62271-200) will be preferable.
- g) All louvers (if provided) shall have very fine brass or GI mesh screen. Tight fitting gasket /gaskets are to be provided at all openings in relay compartment. Relays shall be fully flush mounted on the switchgear panels at a suitable height from operator point of view.
- h) Switchgear shall have an Internal Arc Classification of IAC-A-FL / A-FLR 25 KA,1 sec. (as per EI guidelines) The switchgear construction shall be such that the operating personnel are not endangered by breaker operation and internal explosions, and the front of the panels shall be specially designed to withstand these. Gas Pressure relief device/Explosion Vent/Pressure relief duct shall be provided for each SF6 gas compartment, so that in case of a fault in a compartment, the gases produced are safely vented out, thereby minimizing the possibility of it's spreading to other compartments and panels. The pressure relief device/Explosion Vent/Pressure relief duct shall not however, reduce the degree of protection of panels under normal working conditions.
- i) The switchgear shall be cooled by natural air flow.
- j) Suitable interlock & Indications shall be provided to prevent opening of any HT compartment doors, in case the incoming HT supply is ON.
- k) Suitable base frames made out of *stainless*-steel channels shall be supplied along with necessary anchor bolts and other hardware, for mounting of the switchgear panels. These shall be

dispatched in advance so that they may be installed and levelled when the flooring is being done, welding of base frame to the insert plates shall be in Contractor's scope. The Contractor may offer panels with built in base frame ready for dispatch and suitable for installation on indoor cable trenches.

- l) The switch board shall have the facility for extension on both sides. The facility of extension of additional breakers (to existing set up) for future expansion shall be provided.
- m) The manufacturer shall give guarantee for maximum leakage rate of SF₆ gas will be lower than 0.1 % per year, sealed FOR LIFE pressure system and guarantee no gas handling at a site during extension, removal and installation at site. In case of Gas leakage, the GIS should have the capability to withstand di-electric strength at 1bar pressure. Separate gas monitoring sensors should be available for all the gas filled chambers.
- n) The minimum operating SF₆ gas pressure shall be 1.2 bar. Alarm shall be generated if the SF₆ gas pressure drops to 85% of the minimum operating pressure and if it further drops below 80% the Circuit breaker shall trip & go into lockout mode.
- o) Thermostatically controlled space heater with common MCB shall be provided for various compartments.
- p) The SF₆ gas insulated metal enclosed switchgear shall be constructed from corrosion resistant stainless-steel sheet of min 2 mm thickness, filled with SF₆ accommodating the primary switching devices (Bus bar, VCB and Three position disconnect or cum earthing switch) and all live parts. This panel complying ingress protection min IP 65.
- q) The interconnection of individual panels shall not require any gas work neither for installation at site nor for extension of the panel board. It shall be possible to extend the panel board on either side.
- r) All the mechanical parts shall be surface treated to prevent corrosion.
- s) In case of non-gas enclosing parts of the offered panels are with painted design, the panels must be suitably treated, and powder coated with 60-70-micron thickness, to achieve indoor worthiness and corrosion protection and should pass salt spray test as per ISO 9227-2017.
- t) It shall be with pressure relief device with controlled direction of flow of the hot gasses generated in rare event of internal arc. The panel board with minimum gas pressure shall withstand the rated highest system voltage. Temperature compensated gas density monitor shall be provided on the front side to monitor SF₆ gas and for interlock purpose. The design of the panel should be such that no permanent or harmful distortion occurs either when being lifted by eyebolts or when moved into position by rollers.
- u) Paint shade of Indoor Switchgear shall be 694 /RAL 7032 as per IS:5(Dove Grey).
- v) SF₆ gas pressure and density should maintained as per relevant IS and IEC, if gas pressure or density goes below specified limits, breaker should go in lockout mode.

6.1.1.4 TECHNICAL DATASHEET FOR 11KV GAS INSULATED SWITCHGEAR

Sl. No	Description	Technical Parameters
1	Switchboard	-
2	Manufacturer's Name	By Contractor
3	Type	-----
4	Standards Followed	IS/ IEC 62271-100/200
5	Main Bus bar	
	a) Current Rating	800A
	b) Material	CU
	c) Grade	Electrolytic Cu
	d) Whether Joints are Silver Plated	N.A
	e) Thickness of Coating	N.A
6	Earth Bus bar	
	a) Current Rating	25kA
	b) Material	CU
	c) Grade	Electrolytic Cu
	d) Whether Joints are Silver Plated	N.A
	e) Thickness of Coating	N.A
7	Continuous current Rating for Ambient Condition of site when installed in IP 65 Switch board	
	a) Main Bus bar at Ambient Specified	800A
	b) Tappings at Ambient Specified	800A
8	Temperature rise of Bus bars while	
	a) Carrying rated Current and Installed in IP65 enclosure at an Ambient Temp specified.	As per IS/IEC-62271
	b) Under Short Circuit Condition	N.A
9	Degree of Protection of Enclosure	SF6 gas chamber- Stainless Steel IP65 Drive-IP2X Low Voltage-IP3X
10	Minimum Clearance in Air	

Sl. No	Description	Technical Parameters
	a) Between Phases	Since all parts in SF6, clearance is not applicable.
	b) Between Phase to Earth	Since all parts in SF6, clearance is not applicable.
11	Clearance required at the Back & Front of Panel	AFL: 1700 mm @ front and minimum 1200mm from back (in case of AFLR)
	Overall Dimension of the Switch Board (mm)	
	a) Length	In line with Switch Board Configuration
12	b) Width	450m/ 600mm
	c) Depth	1400mm
	d) Height	2400/2800mm
	a) Access Height (mm)	
	i) Maximum	1850 mm height of lock of LV box door (as per site feasibility)
12	ii) Minimum	830 mm height of cable box handle
	b) Weight of Panel Board (kg)	
	i) Maximum:	By Contractor
	ii) Minimum:	By Contractor
	Insulation Level including all the Components	
13	a) Power frequency withstand Voltage for 1 min	28 kV
	b) 1.2/50 μ sec Impulse Withstand Level	75 kV
14	Circuit Breakers	
(i)	Manufacturer's Name	
(ii)	Type	
(iii)	Manufacturer's Type reference	
(iv)	Closing Mechanism	spring
(v)	Normal Current rating in Air & corresponding	800A
(vi)	Ambient Temperature	40°C
(vii)	Derating factor for Ambient condition at Site	N. A.
(viii)	Service Voltage & Frequency	11 kV, 50 Hz
(ix)	Maximum Voltage at which CB can Operate continuously	12 kV

Sl. No	Description	Technical Parameters
(x)	Rated Making Capacity	63kAp
(xi)	Rated Breaking Capacity	25kA
(xii)	a) Symmetrical	25kA
(xiii)	b) Asymmetrical	27kA
(xiv)	Short Circuit Withstand Capacity	
	a) 3 Sec	25kA
(xv)	Total Make time	Within 60ms
(xvi)	Total Break time	Within 60ms
(xvii)	No. of Breaks per pole	1 No.
(xviii)	Total Length of Break per pole	
(xix)	No. of Auxiliary Contacts (NO/NC) for Engineer use	8
(xx)	Type of Arc Control Device	Vacuum
(xxi)	Arc Duration time	
	a) 100 % Load Current	Within 10ms
	b) 10 % Load Current	Within 10ms
(xxii)	Spring Charging Motor	
	a) Type	Universal Motor
	b) Voltage	240 V AC
	c) Rating in kW	0.223
	d) Protection relay provided	Not Applicable
	e) Protective MCB s provided	Yes
(xxiii)	Power required for :	
	a) Closing	
	i) Momentary	250W
	b) Holding	N.A
	c) Tripping	250W
	d) Time taken for Charging Motor to Charge Spring completely	8 seconds
(xxiv)	Number of consecutive operation the breaker can withstand and the recommended interval between these operations:	O-0.3Sec-CO-3Min-CO
(xxv)	Number of short circuit current interruption after which the breaker requires attention & maintenance	by Contractor

Sl. No	Description	Technical Parameters
(xxvi)	Number of normal operations after which the breaker requires attention & Maintenance	10000
(xxvii)	Rated capacitor breaking current of breaker/ contactor of each rating	N.A.
(xxviii)	Confirm that trip and closing coils will be suitable for 110 V DC and the spring charging motor will be suitable for 240 V AC	Yes
(xix)	Maximum number of XLPE cables & sizes that can be terminated safely in the cable chamber without extension panel	
	a) Single core (Size & No. of Runs)	As Applicable
	b) Three core (Size & No. of Runs)	As Applicable
(xx)	Maximum no of cables that can be terminated in the cable extension box (Please state the dimensions of such cable extension Box)	N.A
(xxi)	Minimum available distance from the bottom of the panel to the terminals in cable box/chamber for terminating cables	500mm.
(xxii)	Weight of circuit breaker and truck	fixed mounted GIS
15	Instrument Transformers	
(i)	Makes	
	a) CTs	By Contractor
	b) PTs	By Contractor
(ii)	Standards followed	IS/IEC
(iii)	Confirm that CTs and PTs will be epoxy resin cast insulated	CT foil, VT metal-cast resin
(iv)	3 second short time current rating of CTs, kA.	25kA
(vi)	Dynamic current rating of CTs, kA :	63kAp
(vii)	Confirm that accuracy classes shall be as specified and ratios and capacities shall be as required	Yes/No
(viii)	Confirm that all protective, metering, control and annunciation devices, transducers as specified shall be provided	Yes/No
(ix)	Enclose technical particulars, data sheets, catalogues of all types of relays and other plant being offered by you	Yes/No
17	SF6 Gas Pressure	1.2 bar
18	Gas Leakage Rate	< 0,1% per year
19	Gas handling Requirement at Site	No Gas handling allowed at site

Sl. No	Description	Technical Parameters
20	Cable Terminations	
	Make	By Contractor
	Type	Inner cone / Outer Cone

6.1.1.5 Busbar and Insulators: -

- a) 11KV bus bar can be housed in SF6 gas chamber. 11 kV bus bars shall be made of electrolytic copper and shall be rated for 800 Amps continuous current. Cross sectional area shall not be less than 500 sq.mm. and bus bar size calculation /supporting type test report shall be submitted for approval. Current density of copper shall not exceed more than 1.6Amps/sq. mm. Bus bar cross-section shall be uniform throughout the length of switchgear panel. The bus bar edges/ends shall be rounded off/chamfered so that there will not be any sharp edges/projections. Busbar shall be supported on the insulators such that the conductor expansion and contraction are allowed without straining the insulators and should withstand electrical and mechanical stresses due to specified short circuit currents. (IS)
- b) All piping for SF6 gas shall be made of copper & their fittings shall be made of nonmagnetic stainless steel.
- c) Busbar insulators shall be of arc and track resistant, high strength, non-hygroscopic, non-combustible type and shall be suitable to withstand stresses due to over-voltages, and short circuit current. In case of organic insulator partial discharge shall be limited to 50 Pico coulomb at rated Voltage X $1.1/\sqrt{3}$ as per IS 3156.
- d) All busbars shall have suitable phase identification. Bus switching scheme shall be as per Engineer.
- e) The temperature of the bus bars and all other equipment, when carrying the rated current continuously shall be limited 65deg C for tin plated joints and 75 deg C for silver plated joint above ambient temperature 40deg C as per the relevant Standards.
- f) Clearances between phases and between phase and earth shall be as per OEM type tested design complying to relevant IEC standards.

6.1.1.6 Circuit Breaker: -

- a) Vacuum circuit breaker shall be used for 11KV GIS (Gas Insulated Switchgear) 11 KV Vacuum circuit breaker shall comprise of three single pole interrupting units or 3-pole interrupting unit, operated through a common shaft by a sturdy operating mechanism. Circuit breaker shall be re-strike free, stored energy operated and trip free type. Motor wound closing spring charging shall be preferred. Anti-pumping features shall be provided for each breaker. An arrangement of two breakers in parallel to meet a specified current rating shall not be acceptable. (No parallel interrupter).
- b) Circuit breaker shall be provided with two trip coils.

- c) Suitable indicators shall be provided on the front of panel to indicate OPEN / CLOSED conditions of the circuit breaker, and CHARGED / DISCHARGED conditions of the closing spring, SF6 gas density monitor for all gas compartment.
- d) The rated control supply voltage shall be as mentioned elsewhere under Technical parameters. The closing coil shall operate satisfactorily at all values of control supply voltage between 85-110% of the rated voltage. The trip coil shall operate satisfactorily under all operating conditions of the circuit breaker up to its rated short circuit breaking current at all values of control supply voltage between 70-110% of the rated voltage. The trip coil shall be so designed that it does not get energized when its healthiness is monitored by indicating lamps and trip coil supervision relay.
- e) The spring charging shall take place automatically preferably after a closing operation. Breaker operation shall be independent of the spring charging motor which shall only charge the closing spring. Opening spring shall get charged automatically during closing operation. As long as power supply is available to the charging motor, a continuous sequence of closing and opening operations (CO) shall be possible. Spring charging motors shall be capable of starting and charging the closing spring twice in quick succession without exceeding acceptable winding temperature when the supply voltage is anywhere between 85-110% of rated voltage. The initial temperature shall be as prevalent in the switchgear panel during full load operation with 40 deg. C ambient air temperature. The motor shall be provided with overload protection.
- f) Motor windings shall be provided with class E insulation or better. The insulation shall be given tropical and fungicidal treatment for successful operation of the motor in a hot, humid and tropical climate.
- g) For 11kv incomer: Tripping time: 60-70 ms (Including Relay Time) Closing Time < 80 ms.
- h) For 11kv feeder: Tripping time:45-50 ms (Including Relay Time) Closing Time: 40-60 ms
- i) Manual Spring Charging shall be provided. All the basic mechanical ON/OFF Circuit breaker, Disconnect or & earth switch operation, manual spring charge of Circuit Breaker must be possible without opening the door to ensure the operator safety.
- j) Breaker operations (Mechanical Endurance) as per relevant IS/IEC Amended up to date. The circuit-breaker has to control at least 10,000 Make-Break cycles without maintenance. The mechanical life and operating cycles of the vacuum interrupter shall confirm relevant IS/IEC amended up to date.
- k) Tripping coil, closing coil and motor mechanism shall be easily accessible for maintenance purpose.
- l) The circuit breaker shall be provided with motor operated spring charged closing. Spring charging motor shall be suitable for 240V, 50 Hz, single phase AC. Suitable rating starter shall be provided for Motor protection.
- m) Tripping of the circuit breakers shall be through "Shunt trip" coils rated for suitable auxiliary supply. It shall be possible to trip the breaker manually in case of necessity.

6.1.1.7 Disconnecter and Earthing switch

- a) Each Switchgear panel shall be provided with three (3) position disconnecting-cum earthing switch of required rating.
- b) It shall be possible to control these switches from front of the panel & remotely from SCADA *from operation control centre (OCC)*.
- c) Necessary indication shall be provided on the front of the panel for Close/Open status of the three position switches.
- d) The safe, positive and fool proof interlocks shall be provided for personnel safety and equipment safety.
- e) Key interlocks shall be provided for local manual operations.
- f) Mechanical interlocks shall be provided for following conditions Three position disconnecter cum earth switch cannot be operated when circuit breaker is closed.
- g) The operating handle /lever cannot be removed until the switching operation has been completed.
- h) Earthing shall be additionally secured against" de-earthing" by providing a padlock.
- i) The cable compartment cover can only be opened if the panel is earthed.
- j) In addition to above, relevant all electrical interlocks shall also be provided.
- k) Disconnecting switches shall be motor operated as SCADA is implemented. Isolators or isolators combined with earthing switches (3 position switches) shall be motor operated. In cases of emergency, manual operation must be possible.
- l) The earthing position for all 3 phases must be visible via a mechanical position indicator (MIMIC) directly connected to the drive shaft on panel front Fascia. The mechanical operation of isolator / 3 position disconnects or should be with door close only to insure operator safety.

6.1.1.8 Control and Interlocks: -

- a) The circuit breaker shall normally be controlled remotely from SCADA system (OCC) through closing and trip coils. However, it shall also be designed to control locally from Indoor Switchgear panel. Suitable mimic on Panel shall be provided.
- b) Facilities shall be provided for mechanical tripping of the breaker in an emergency. Facility shall also be provided for manual charging of the stored energy mechanism for a complete duty cycle.
- c) Necessary mechanical & Electrical interlocks shall be provided between CB, Isolator & Earth switches for safe operation.
- d) Each CB, Isolator & earth switch shall have 8 NO + 8 NC Auxiliary spares of good quality (corrosion free and easy for making connection) for future use. It should be located at accessible position in panel.
- e) All the binary inputs/outputs shall be wired to the terminals & kept ready for future SCADA connectivity.

6.1.1.9 Earthing and Earthing Devices

- a) The grounding system for GIS shall be designed and provided as per IEEE-80-2000 and CIGRE- 44 to protect operating staff against any hazardous touch voltages and electro-magnetic interferences.
- b) The earth busbar made of electrolytic high-grade copper with cross sectional area of minimum 240 sq. mm shall be provided at the bottom in all the panels and interconnected with adjacent panels in the panel board through a connecting link to form a common earth busbar for the entire panel board ready to connect to the substation earthing grid. It shall be welded to the framework of each panel and each breaker earthing contact bar. The earth bus shall have sufficient cross section (minimum 240 sq. mm) to carry the momentary short-circuit and short time fault currents to earth without exceeding the allowable temperature rise.
- c) Suitable arrangement shall be provided at each end of the earth bus for bolting to station earthing grid. All joint splices to the earth bus shall be made through at least two bolts and taps by proper lug and bolt connection.
- d) All non-current carrying metal work of the switchboard shall be effectively bonded to the earth bus. Electrical continuity of the whole switchgear enclosure frame work and the truck shall be maintained even after painting.
- e) All metallic cases of relays, instruments and other panel mounted equipment shall be connected to earth by independent stranded copper wires of size not less than 2.5 sq. mm. Insulation color code of earthing wires shall be green. Earthing wires shall be connected to terminals with suitable clamp connectors and soldering shall not be acceptable. Looping of earth connections which would result in loss of earth connection to other devices, when a device is removed is not acceptable. However, looping of earth connections between equipment to provide alternative paths of earth bus is acceptable.
- f) PT and CT secondary neutral point earthing shall be at one place only on the terminal block. Such earthing shall be made through links so that earthing of one secondary circuit may be removed without disturbing the earthing of other circuits.
- g) The panel shall have Voltage Presence Indicator (VPI) to warn the operator against earthing of live connections.
- h) All hinged doors shall be earthed through flexible earthing braid.

Separate earthing for switchgear and Control & Relay panel shall be provided.

6.1.1.10 CURRENT TRANSFORMERS:

- a) The C.Ts. being prone to failure due to various reasons, the quality and reliability of the CTs are of vital importance. C.T. shall be rated for 25 kA for 3 sec. short time current. Insulation used shall be of very high quality, details of which shall be furnished in the technical offer.
- b) The instrument security factor for metering core shall be low enough but not greater than 5 at lower ratio. This shall be demonstrated on metering core in accordance with the procedure specified in relevant IS/IEC.

- c) All current transformers for GIS shall be ring type (Tape wound / resin cast). Suitable insulated copper wire of electrolytic grade shall be used for CT secondary winding. Multi ratio in CT shall be achieved by reconnection of secondary winding tapping.
- d) Secondary terminal studs shall be provided with at least three nuts, two plain and two spring washers for fixing leads. The stud, nut and washer shall be of brass, duly nickel plated. The minimum outside diameter of the studs shall be 6 mm. The length of at least 15 mm shall be available on the studs for inserting the leads. The space clearance between nuts on adjacent studs when fitted shall be at least 10 mm.
- e) The CTs shall be resin/epoxy cast. Contact tips on primary terminals shall be silver plated. Correct polarity shall be invariably marked on each primary and secondary terminal.

6.1.1.11 POTENTIAL TRANSFORMER

- a) Potential transformers shall be single phase units connected to the line side in the respective incomer. H.V side shall be connected in star formation and L.V. side in star/open delta formation.
- b) PT may be provided in a separate compartment. The primary and secondary contacts (moving & fixed type) shall have firm grip while in service. Service position locking mechanism shall be provided and indicated by Contractor in relevant drawing. Rigidity of primary stud point with earth bus in service position shall be confirmed.
- c) P.T. shall be epoxy/resin cast. Contact tips of primary/secondary contacts shall be silver plated. Correct polarity shall be distinctly marked on primary and secondary terminal.
- d) Secondary terminal studs shall be provided with at least three nuts, two plain and two spring washers for fixing leads. The stud, nut and washer shall be of brass, duly nickel plated. The minimum outside diameter of the studs shall be 6 mm. The length of at least 15 mm shall be available on the studs for inserting the leads. The space clearance between nuts on adjacent studs when fitted shall be at least 10 mm.
- e) Each secondary core will be protected by suitable MCB.
- f) In case of 2 Power Transformers are in parallel, 2nd core of PTs shall be used for directional protection.

6.1.1.12 Low voltage Compartment (Instrument Chamber)

- a. The panels shall be with low voltage compartment consisting of control switches, indication and metering instruments, protection relays and other secondary equipment's. The dynamic mimic shall be provided on the front fascia and not on the LV chamber.
- b. The front side shall have Mimic as per single line diagram with control switches and mechanical and electrical 'Position indicators' circuit breakers, disconnectors and earth switch.

- c. Control switches/Pushbuttons shall be provided adjacent to respective equipment position indicators in Mimic for ON-OFF operation of circuit breakers, disconnectors and earth switches.
- d. The SCADA compatible Metering instrument shall be provided.
- e. Live line Indicators: - Capacitive voltage indicators shall be provided on feeder side in incoming and outgoing feeders to indicate the voltage presence in each phase and to prevent the closing of earth switch in case the part is live. It shall have sufficient output contacts for substation Automation System and interlock purpose.

6.1.1.13 Numerical Protection Relays

Numerical relays shall be of modular type and have native IS/IEC 61850 (to latest version/amendment of the series of this standard) communication support for RTU/SCADA integration. Relay shall have graphical LCD dot matrix display with single line diagram mimic with control, indication, programmable function key and LED' relay shall have minimum protections as per SLD however any addition protection if required, is to be considered by the contractor or OEM (price to be included in the offer). Protection relay PCB hardware should be with conformal coating to protect the relay from hazardous environment.

Relay hardware, control cables and separate arc sensors shall be included. Any arc flash fault in the cable compartment is selectively cleared by the feeder protection relay.

NOTE: Erection, Testing & Commissioning of the GIS panel must be done through the OEM of GIS panel only & OEM will issue the certificate of successful commissioning of GIS panel in all respect.

6.1.1.14 11kV SWITCH BOARDS

The switchgear and busbar shall meet the "sealed pressure system" criterion in accordance with the IS/ IEC 62271. The manufacturer certificate shall confirm that maximum *gas* leakage rate is lower than 0.1 % / year. It shall provide full insulation, for switchgear insensitive to the environment (temporary flooding, high humidity, etc.), IP65 degrees of protection in accordance with recommendation IS/ IEC 60529.

- a) The switchgear shall be maintenance-free and the switchboard shall be low-maintenance.
- b) The switchboards drive suitable for IP protection.
- c) The cable compartment shall integrate:
 - i. Adjustable cable fixing devices
 - ii. Earth connecting point
 - iii. Metal partition between cable compartments and tank pressure relief area.
- d) The cable compartment shall be arc resistant and suitable for the following cable connecting systems:

1. Partial insulated cable connectors
2. Fully screened cable connectors
3. Metal enclosed cable connectors according to DIN EN 50181, IS-10314, IS/IEC-62155 and IEC-60137 standards to latest versions.

The color shall be as per Engineer requirement / as approved for the enclosure and mimic panel. The switchgear and switchboards shall be designed so that the position of the different devices is visible to the operator on the front of the switchboard and operations are visible as well. In accordance with the standards in effect, the switchboards shall be designed to prevent access to all live parts during operation without the use of tools.

6.1.1.14.1 EARTHING OF METALLIC PARTS

There shall be continuity between the metallic parts of the switchboard and cables so that there is no electric field pattern in the surrounding air, thereby ensuring the safety of people. The substation frames shall be connected to the main earth busbar without dismantling any bus bars.

6.1.1.14.2 EARTHING OF THE MAIN CIRCUIT

The cables shall be earthed by an earthing switch with short-circuit making capacity, in compliance with IS/IEC 62271-102 standard. The earthing switch can only be operated when the switch is open. The earthing switch shall be fitted with its own operating mechanism and manual closing shall be driven by a fast-acting mechanism, independent of operator action. Mechanical interlocking systems shall prevent access to the operating shaft to avoid all operator errors such as closing the earthing switch when the switch is closed.

6.1.1.14.3 FEEDER WITH SWITCH-DISCONNECTOR

They shall be maintenance-free. The position of the power contacts and earthing contacts shall be clearly visible on the front of the switchboard. The position indicator shall provide positive contact indication in accordance with IEC 62271-102 standard.

The switches shall be of the "increased operating frequency" in accordance with IEC 62271-102 standard. They shall have 3 positions, "open-disconnected", "closed" and "earthed", and will be constructed in such a way that interlocking prevents unauthorized operations. The switch disconnecter and earthing switch shall be equipped with two separate operating entry points. Manual opening and closing will be driven by a fast-acting mechanism, independent of operator action. Each switch can be fitted with an electrical operating mechanism in a specially reserved location, by addition of a motorization unit and without de-energizing the switchboard. The switch and earthing switch operating mechanism shall have a mechanical endurance of at least 1000 operations, in line with IS/IEC 6227-102.

6.1.1.14.4 TRANSFORMER PROTECTION WITH VACUUM CIRCUIT BREAKER

The circuit breakers shall be of the maintenance-free, vacuum type. The position of the power and earthing contacts shall be clearly visible on the front of the switchboard. The position indicator shall provide positive contact indication in accordance with IS/IEC 62271-102 standards and prove reliability of indication in accordance with IS /IEC 62271-102 & 6.105 standard. An operating mechanism can be used to manually close the circuit breaker and charge the mechanism in a single movement. An independent mechanism shall be fitted for the 3-position earthing switch and disconnecter and include a local system for manual tripping by an integrated push button. There will be no automatic reclosing. The circuit breaker shall

be associated with an integrated protection unit that will operate without any auxiliary power supply and shall include:

- a) Three toroidal transformers incorporated in the transformer tee-off bushings,
- b) An electronic relay (Self Powered),
- c) A low energy release,
- d) A system protection testing (with or without CB tripping)

6.1.1.14.5 MV METERING

MV Metering shall be carried out by a factory assembled type tested cubicle.

The metering cubicle shall withstand internal arc. Connection with adjacent cells will be direct through bus bar but MV cables shall be possible.

VT's and CT's to comply with type DIN 42600 standards, IS-2705, IS-16227 and the following configuration shall be available:

- a) 2 VT's phase-phase,
- b) 2 VT's phase-earth,
- c) 3 VT's phase-earth
- d) 2 or 3 CT's. (as per design)

6.1.1.14.6 Substation Buildings

Contractor Shall design and construct the substation buildings and shall be responsible for land preparation, Boundary wall, entrance gate, foundation, support anchor block, Baffle wall between transformers, door, windows including architecture, civil, structural, drainage, plumbing, conduiting, wiring, provision of lights, fans, Exhaust fan. All such parts accessories shall be deemed to be within the scope of specification weather specifically mentioned or not. The soil investigation for foundations for building work, foundation etc shall be undertaken and Engineer approval shall be taken. Electrical resistivity of soil for designing safe grounding system shall be done.

The Grade of concrete should be as per approved design and Minimum M-25 as per IS 456 for all civil construction of Substations. The cement plaster shall be 1:4 (cement: sand) and, *Brick class designation not less than 7.5 shall be used.* The earth compaction shall not be less than 95%. This site above to cleared of all existing encumbrances, levelled and compacted. The finished ground level of substation site shall be above the highest flood level HFL in the region. The finish ground level shall be at least 600 mm above the main rail /road level near to site.

The drainage of substation shall be provided as per best engineering practices to prevent surface flooding and cooling of water. suitable drainage system and earth recharge pit shall be made. All fencing items i.e., wire mesh, angles, flats etc shall be GI.

The ceiling height of the substation building shall be minimum 4.5 above floor level. The plinth of the substation building shall be 300 mm above the natural ground level of substation.

All windows of substation building shall be fitted with burglar bars firmly attached to the structure of building. The windows shall be appropriate section and shall be fitted with locks. The windows shall be provided with minimum 5mm thick toughened glass. Doors and shutters shall be sturdy and having corrosion proof material. Parapet wall shall be

provided on windows and doors to avoid of ingress of rain water. Toilet rooms and water supply arrangement shall be made in the substation building along with provision of submersible pump.

Substation building shall be provided necessary lighting and Fans. The battery room shall be provided with exhaust fan and acid resistant tile on the floor on the site wall upto height of 1.5 meter. The ceiling shall be painted with acid resistant paint. Substation building shall be properly earthed against any lightning.

Necessary trenches shall be made and these shall be covered with GI chequered sheets 8 mm thick.

The indicative layout of the substation along with area has been given in the Tender drawings. Contractor shall submit the final layout design for Engineer's approval after taking consideration the sizes of various equipment, other requirement mentioned in these specifications.

6.1.2 11 kV RING MAIN UNIT (RMU): -

RMU type, metal-enclosed indoor switchgears, shall be compact switchboard and comply to following requirements. The RMU shall be capable of being installed in either concrete indoor substations or in compact metal substations and kiosks with an IP67 rating.

6.1.2.1 FUNCTION REQUIREMENTS

The following functions shall be available:

- a) Feeder with switch-disconnector
- b) Transformer protection with vacuum circuit breaker

6.1.2.2 Enclosure:

The RMU enclosure shall be made up of CRCA of 3 mm thickness with appropriate rust prevention treatment suitable for humid and corrosive atmospheres / alternatively of stainless steel SS316L of at least 1.6 mm thickness. The rating of enclosure shall be suitable for operation on three phase, three wire, 11 KV, 50 cycles, A.C. System with short time current rating in the range of 20kA – 25 kA for 3 seconds with Panels. The enclosure shall provide full insulation, making the Switchgear insensitive to the environment like temporary flooding, high humidity etc. The active parts of the Switchgear shall be maintenance-free and the unit shall be minimum -maintenance. The Switchgear and Switchboards shall be designed such that the position of the different devices is visible to the operator on the front of the Switchboard and operations are visible. The RMU metal parts shall be made of high thickness high tensile steel grit/short blasted, thermally sprayed with Zinc alloy (not for galvanized steel), phosphate and subsequently painted with Polyurethane based powder paint, the overall (including outer and inner paint layer), the thickness of paint layer shall be not less than 150 microns.

6.1.2.3 Configuration requirements

Extensible range:

3 function unit: Switch-disconnector Load Break Switch (LBS)- Switch-disconnector (LBS)- Transformer protection with vacuum circuit breaker. The RMU shall meet the criteria for compact, metal-enclosed indoor switchgear in accordance with IS/ IEC 62271-200:

Switchgear classification: PM class

Loss of service continuity class: LSC2

It shall include, within the same metal enclosure, the number of MV functional units required for connection, power supply and protection of transformers.

6.1.2.4 RMU BUSHINGS AND CABLE TERMINATIONS Bushing

It is preferable to have all bushings accessible from the front of the RMU. Bushings along the sides or the rear of the RMU are not acceptable. For each cable compartment, the bushing shall be at the same height in order to facilitate a possible reversal of the cables. The bushing should be conveniently located for working with cables specified and allow for the termination of these cables:

- a) 630 A M16 bolted connectors for switch-disconnectors and vacuum circuit breakers functions
- b) 200 A plug-in connector for transformer protection feeder with fuse combination. The profiles of the cable connection bushings shall be in compliance with IEC-60137, IS- 10314, IS/IEC-62155 standards of latest versions. A cable clamp arrangement must be provided for all network cables terminated on the RMU.

6.1.2.5 PADLOCKING FACILITIES

Circuit breakers, fuse-switches combination, switches and earthing switches can be locked in the open or closed position by at least 1 padlock.

6.1.2.6 VOLTAGE INDICATORS AND PHASE COMPARATORS

Each function shall be equipped with a voltage indicator box on the front of the device to indicate presence of voltage in the cables. The capacitive dividers will supply low voltage power to the lamps. Three inlets can be used to check the synchronization of phases. This device shall be in compliance with IEC 62271-206, IEC 61243-5(to latest versions).

6.1.2.7 FAULT PASSAGE INDICATORS (FPI)

The FPI shall facilitate quick detection of faulty section of line. The fault indication may be on the basis of monitoring fault current flow through the device. The FPI should be self-powered and should have internal lithium battery for external indication and setting of FPI in the absence of current. The FPIs shall include:

Fault detection - Phase to phase and Phase to earth faults.

One potential-free output contacts for hardwiring to RTUs. On this basis, the SCADA will be able to monitor phase / earth fault condition. Local fault indications – LED/ LCD display on FPI front panel along with LED indication on front panel of RMU enclosure.

The FPI should indicate load current on display to understand loading of RMU.

Multiple reset option –

- a) End of time delay
- b) Remote reset (Via potential free input contact of FPI)
- c) Manual reset (Reset button on front panel of FPI)
- d) Automatic reset on current restoration.

The characteristics of the FPIs shall include:

- i. Phase fault thresholds configurable from at least 100 to 800 A
- ii. Earth fault thresholds configurable from at least 20 to 200 A
- iii. Multiple number of steps for adjusting phase and earth fault thresholds.
- iv. Fault current duration range configurable.

RMU should have VCB, FRTU and FPI supplied and integrated by the same OEM to ensure seamless integration.

6.1.2.8 OPERATING LEVER

An anti-reflex mechanism on the operating lever shall prevent any attempts to reopen immediately after closing of the switch or earthing switch.

All manual operations will be carried out on the front of the switchboard.

6.1.2.9 FRONT PLATE

The front plate shall have suitable IP degree of protection. The front shall include a clear mimic diagram which indicates the different functions.

The position indicators shall give a true reflection of the position of the main contacts. They shall be clearly visible to the operator. The lever operating direction shall be clearly indicated in the mimic diagram.

The manufacturer's plate shall include the switchboard's main electrical characteristics.

6.1.2.10 REMOTE CONTROL OF THE RMUs

A limited number of applications for remote operation of the RMU are required.

Remote operation of the RMUs line switches must be possible using motors fitted to the operating mechanism. It shall be possible to fit the motors either directly in manufacturing plant or on site when required. Installation on site shall be possible with the RMU fully energized and manufacturer should provide detailed instructions for installation to the control mechanism.

Auxiliary contacts for remote indication of switch status are also required. The fitting of the motors to the mechanism must not in any way impede or interfere with the manual operation of the switches. An auxiliary contact to prevent motorized operation of the mechanism while the operating handle is inserted into the operating point must also be provided. The device shall be fully designed for use in a hot, humid atmosphere and shall be low maintenance. All metallic parts shall have rust protection. Two lifting rings shall be installed on the top of the switchboards for handling.

6.1.2.11 TECHNICAL DATASHEET FOR RING MAIN UNIT (RMU)

Network	Three phases - Three wires
Rated Voltage	12 kV
Service Voltage	11 kV
System Frequency	50 Hz
Lightning Impulse withstand Voltage	
<ul style="list-style-type: none"> • Phase to phase, phase to earth • Across the isolating distance 	75kV
	85 kV
Power Frequency withstand voltage	28 kV rms - 1 min

Rated Normal Current	
a) Line switch	630 A
b) Transformer feeder	630 A
c) Branch circuit breaker feeder	630 A
Rated Short time current withstand (3 sec)	20 - 25 kA
Internal Arc IAC – AFL (SF6 tank and cable box)	20kA for 1sec
Rated Short circuit making capacity of line switches and earthing switches	62.5 kA peak at Rated Voltage
Number of operations at rated short circuit current online switches, earthing switches and CB	5 closing operations
Rated load interrupting current	
Line switch	630 A rms
Rated cable charging interrupting current	
Line switch	30 A
Number of mechanical operations	
a) Line switches and earthing switches	1000 O/C
b) Switch-fuse combination	1000 O/C
c) Circuit breaker	2000 O/C
Number of electrical operations at full load breaking current	100 O/C
Number of operations at rated short circuit current on circuit breaker	Manufacturer's design

6.1.3 ACCESSORIES FOR 11 KV SYSTEM: -

6.1.3.1 DISTRIBUTED I/O

Distributed Input /Output (I/O) are required for using the advantages of a double-sided feeding at the 11 kV System. The distributed I/Os will be provided by the contractor of Electrical /SCADA. All data points of the 11 kV-System run to the distributed I/Os.

6.1.3.2 FIRE EXTINGUISHER

CO2 fire extinguishers shall be provided in substation, equipment room . This includes necessary fixing arrangement, accessories etc.

6.1.4 ACCESSORIES FOR EACH 11KV SUB –STATION: -

Each 11 kV sub- station shall be equipped with:

- a) Single Line Diagram of 11 kV-System of tunnel with glass-covering
- b) Sheet / Board including the instruction for first aid by electrical accidents
- c) - Sheet / Board including the instructions for fire-fighting measures in electrical plants
- d) Prescription of operation of High Voltage Systems
- e) Suspension Device for accessories
- f) Warning Sign “Attention High Voltage”
- g) Voltage Detector
- h) Earthing Accessories and other safety equipment as per standard.

6.1.5 OPERATION MODES: -

All switching equipment, which shall be equipped with a remote control switch, shall need a changeover switch. Therewith a switching between local- or remote-control is possible.

6.1.5.1 LOCAL CONTROL:

If the changeover switch is positioned at “local control”, all up streamed switching equipment has to switch off the remote controlling. The whole switchgear interlocking shall also work at local control.

6.1.5.2 REMOTE CONTROL:

At this position of the changeover switch the user shall be able to choose between different switch possibilities out of a predefined matrix. Generally, it shall be possible to decide which of the two feedings shall be switched. A remote controlling of the high voltage power supply shall only be possible, if:

- a) No changeover switch is positioned at local control
- b) No earthing switch is switched
- c) No fault is stored.

6.1.6 APFC PANEL WITH ALL ACCESSORIES: -

SITC of APFC Panel of 250 kVAR heavy duty capacitor bank with MCCB as incomer or as per site requirement. Automatic Power Factor Correction (APFC) panel shall be totally enclosed, metal clad, sheet steel fabricated, fixed feeder type, dust and vermin-proof, free standing, floor mounting type. The enclosure shall be pre-treated as per 11 tanks process and finished with powder coating of shade RAL 7032. The panel shall be built to ensure:

- a) Proper thermal design, by providing louvers and fans in appropriate location,
- b) Accurate selection of switchgear, capacitors-reactors and others in the panel.
- c) Safety during operation, inspection and maintenance.

6.1.6.1 Minimum features required are: -

- i. Advanced microcontroller based APFC relay
- ii. Four quadrant sensing
- iii. Reliable switching sequence
- iv. Hunt free operation
- v. Reliability in operation
- vi. Program based rotation of duty cycle pre set
- vii. Programming ensures stability
- viii. Faster response time

- ix. Accurate compensation
- x. Contactor duty cycle optimization in case of equal step sizes
- xi. Various system parameter display
- xii. Fully automatic / manual setup and operation
- xiii. Minimal joining in all the connections to ensure better reliability and lower losses.
- xiv. Use of special connecting cables suitable for high temperature withstands.
- xv. Flush mounted meter to indicate line voltage and current.

6.1.6.2 PROTECTION:

The following protection schemes must be provided for APFC panels:

- a) Over voltage: The APFC equipment must be switched off in the event of over voltage with suitable over voltage relay.
- b) Under voltage: This condition is not harmful. But protection must be provided to protect system from under voltage.
- c) Over Current: All the switchgears are selected on a higher maximum current carrying capacity. Hence, suitable over current relays with alarm can be used for over current protection.
- d) Short circuit protection: At the incomer level short circuit protection shall be provided by devices such as MCCB, ACB. At the step protection level, MCCB/ MCB shall be used Thermal Overload: The APFC controller must be tripped in cases where internal ambient temperature exceeds the limits. Reactors are also provided with thermal switches, to trip in the case of temperature increase.
- e) Earthing: Two earthing points shall be provided in the APFC panel for connection with the earth bus. This will ensure the overall safety of operating personnel and equipment protection in case of earth faults.
- f) Earth Leakage Relay: It must be connected at power incoming side of the panel. Earth leakage relay must be provided to safeguard the operator by tripping the incomer.
- g) Timers: Capacitors require a minimum discharge time of approximately 60 seconds after they are switched off before they can be switched on again. This shall be set in the APFC controller. Capacitors must be provided with discharge resistors.
- h) Over Temperature trip mechanism: Temperatures sensors (two thermostats) to be connected for operation of the fans/ industrial air conditioners above 35°C and to disconnect main incomer of APFC if the temperature exceeds 55°C inside the panel.

6.1.7 11/0.433 KV TRANSFORMERS: -

The transformers shall be installed in such away, that no vibrations will be transmitted to the building / construction. The connecting of the 11 kV-cables at the transformers only shall occur with right-angle connectors. Those right-angle connectors shall be calculated into the price of the 11 kV-cable.

6.1.7.1 DRY TYPE 11 / 0.433 KV TRANSFORMER (2000 kVA for Portal sub-station)

Dry transformers shall be built with an air-natural – air-natural cooling (ANAN).

The 11/0.433 kV transformers shall be copper wounded equipped with off-load tap changer on primary side, with positions at +5 %, +2.5 %, ± 0 %, -2.5 % and -5 %. Generally, the tap changers shall operate under OFF-circuit conditions (through the cover) and shall be able to be fixed in any position by an adjusting screw. Winding terminations shall be realized as strip or foil windings. Additional to the turn insulation, the windings shall be embedded with a mixture of epoxy resin.

The mixture of epoxy resin shall be *non-inflammable* and self-extinguishing. Transformers shall be at least fire class F1 according to BS EN IEC 60076-11:2018, IS-11171. The neutral point (on the low-voltage side) shall be designed in a total insulated form, like the phase conductor. The iron core shall be designed with step-lap joints. The yoke shall be mounted with yoke chipboards. The use of bolts is not allowed. The yoke-chipboards of both sides of the yoke shall be linked with pull rods. On the stiffening frame near the ground a base shall be provided for the approach of winches and lifting jacks. Also, eyebolts with a diameter of at least 60 mm shall be provided on the top. The transformer shall be equipped with massive plain wheels, rotatable for lengthwise and crosswise driving. The ground clearance shall be at least 50 mm. The core assembly of Dry type transformers enclosure shall be electrically connected to the transformer tank for effective core earthing. Also copper flexible for earth continuity purpose shall connect different parts of transformers.

6.1.7.2 PROTECTION AND MONITORING EQUIPMENT

For the windings, a temperature monitoring by using separated PTC thermistor detectors for warnings and alarms shall be provided.

6.1.7.3 TECHNICAL DATASHEET FOR DRY TYPE 2000 kVA (11/0.433 KV) TRANSFORMER

Rated power:	2000 kVA
Voltage (primary side):	11 kV
Voltage (secondary side):	0.433 kV
Nominal frequency:	50 Hz
Thermic power loss:	5.5 kW (max.)
No Load Loss	1.3 kW (max)
Cooling:	ANAN
Tapping range:	+ 5%, +2.5 %, ± 0 %, -2.5 %, -5 %
Impedance voltage:	5 %
Vector Group:	Dyn 11
Primary connection:	Totally insulated plug-in connector

Secondary connection:	Connection safe insulating cover to touch with connecting lug.
-----------------------	--

Note: - The contractor shall ensure that equipment provided in substations should be compatible to SCADA, so that they can be operated remotely from OCC.

6.2 11kV HT/LT COPPER CABLE: -

6.2.1 TECHNICAL SPECIFICATION (HT CABLE): -

Three core 11 kV grade, heavy duty power cable with stranded compacted circular copper conductor with non-metallic semi-conducting screening, shielded with extruded semi-conducting compound, cross linked polyethylene insulated, shielded with extruded semi-conducting compound and copper tape, shielded cores laid up with fillers, Galvanized steel wire/strips Armoured and FRLS-ZH cable .

6.2.2 STANDARD: -

The 11 kV cables shall, in general, meet the requirements of the latest edition of the IS 7098 (Part-2) 1985. The cables and components in general shall meet the requirement Standards with latest amendments or equivalent International Standards.

IS:7098 (Part-2) (R2016) 2011:	Specification for cross linked polyethylene insulated PVC sheathed cables
IS:8130 (R2015) 2013:	Specifications for conductors for insulated Electric cables
IS:3975 (R2004) 1999:	Specification for mild steel wires, strips and tapes for armouring of cables
IS:10810 (Part 1 to 55) (R2016)1984:	Speciation for test on cables
IS:5831 (R2016) 1984:	Specification for PVC insulation and sheath of electric cables
IS:10418 (R2016) 1982	Specifications for drums of electric cables
IS:10462 (Part-1) (R2016) 1983:	Fictitious calculations method for determination of dimensions of protective covering of cables
IEC:60754-1 / IEC:60754-2 2011	Determination of the amount of Halogen acid Gas, Determination of degree of acidity of gases
IEC:60332 / IEC:60331 2004	Flammability test for electric cables
BS 7835 2007	Armoured cables with thermosetting insulation for rated voltages from 3.8/6.6 kV to 19/33 kV having low emission of smoke and corrosive gases when affected by fire.

6.2.3 TECHNICAL DATASHEET - FOR HT CABLE

S.NO.	PARTICULARS	3Cx120	3Cx95	3Cx50
1	Make	as per list of approved makes		
2	Voltage Grade in kV (System highest voltage)	6/10(12) or as per Standard	6/10 (12)	6/10 (12)
3	Type	XLPE Cable		
4	Reference Standards	IEC 60502-2, IEC 60228: 2004, BS 7655, IS 5831, IEC 60332,		
5	Conductor			
(i)	Material as per IEC 60228	Annealed Plain Copper		
(ii)	Nominal Cross Section Area (sq.mm)	120	95	50
(iii)	Class of Conductor	Class-2		
(iv)	Shape of Conductor	Stranded Compacted Circular		
(v)	Min. no. of strands	As per IEC 60228		
(vi)	Max. DC conductor resistance 20 °C (Ohm/Km)	As per IEC 60228		
(vii)	AC resistance at 90 °C (Ohm/Km)	As per IEC 60228		
6	Insulation			
(i)	Material as per 60502-2	XLPE	XLPE	XLPE
(ii)	Nominal thickness of insulation(mm)	3.4	3.4	3.4
7	Insulation Screening			
(i)	Material	Extruded Semiconducting compound (bonded type) followed by a layer of copper tape		
(ii)	Min. thickness of extruded layer (mm)	0.3	0.3	0
(iii)	Approx. thickness of copper tape	0.035	0.035	0.035
(iv)	Layer over laid-up	2 layers of Glass Mica Tape applied over conductor		
8	Core Identification	By colored strip Red, Yellow and Blue		
9	Laying Up	Cores laid up suitably		
10	Inner Sheath			
(i)	Material as per IEC 60502 - 2	Extruded LSZH Compound Type ST-8		
(ii)	Min. Thickness (mm)	As per IEC 60502-2		
11	Armouring			
(i)	Material	Single layer of galvanized steel round wire		
(ii)	Nominal Dia of armour wire (mm)	As per IEC 60502		
12	Outer Sheath			
(i)	Material as per IEC 60502 - 2	LSZH Compound Type ST-8		
(ii)	Min. Thickness (mm)	As per IEC 60502-2		
(iii)	Sheath Color	Black		
(iv)	Approx overall dia of Cable (mm)	As per IEC 60502-2		
13	Marking on cable	Make, Electric cable, Voltage Grade, Size of Cable, ---- meter, NR logo		

6.2.4 TECHNICAL SPECIFICATION (LT CABLE): -

S.NO	PARTICULARS	4Cx300	4Cx185	4Cx120	4Cx95	4Cx70	4Cx35	4Cx25	4Cx16	4Cx10	4Cx6	4Cx4	3Cx4	3Cx2.5	3Cx1.5	
1	Make	As per list of approved makes														
2	Voltage Grade (kV)	1.1														
3	Type	Fire Survival Cable														
4	Reference Standards	BS 7846, IS 8130, BS 7655, IS 5831, IEC 60332														
5	Conductor															
(i)	Material	Annealed Plain Copper Conductor as per IS 8130														
(ii)	Nominal Cross Section Area (sq.mm)	300	185	120	95	70	35	25	16	10	6	4	4	2.5	1.5	
(iii)	Class of Conductor	Class-2														
(iv)	Shape of Conductor	Stranded sector shaped							Stranded compacted circular			Stranded circular				
(v)	2 layers of Glass Mica Tape applied over conductor	Yes	Yes	Yes	Yes	Yes	Yes	Yes	Yes	Yes	Yes	Yes	Yes	Yes	Yes	
(vi)	Min. no. of strands	As per IS 8130														
(vii)	Max. DC conductor resistance 20 °C (Ohm/Km)	As per IS 8130														
(viii)	AC resistance at 90 °C (Ohm/Km)	As per IS 8130														
6	Insulation															
(i)	Material	XLPE														
(ii)	Nominal thickness of insulation(mm)	1.8	1.5	1.2	1.1	1.1	0.9	0.9	0.7	0.7	0.7	0.7	0.7	0.7	0.6	
7	Core Identification	Red, Yellow, Blue and Black											Red, Yellow and Blue			

8	Laying Up	Cores laid up suitably by Plain Glass Fibre tape													
S.NO	PARTICULARS	4Cx300	4Cx185	4Cx120	4Cx95	4Cx70	4Cx35	4Cx25	4Cx16	4Cx10	4Cx6	4Cx4	3Cx4	3Cx2.5	3Cx1.5
9	Inner Sheath														
(i)	Material as per BS 7846 : 2000	Extruded LSZH compound													
(ii)	Min. Thickness (mm)	as per BS 7846 : 2000													
10	Armouring														
(i)	Material as per BS 7846 : 2000	Single Layer of Galvanized steel Round Wire													
(ii)	Nominal Dia of armour wire (mm)	as per BS 7846 : 2000													
11	Outer Sheath														
(i)	Material as per BS 7655	LSZH Compound Type LTS-1													
(ii)	Min. Thickness (mm)	as per BS 7655													
(iii)	Sheath Color	Black													
(iv)	Approx overall dia of Cable (mm)	By Contractor													
12	Marking on cable	Make, Electric cable, Voltage Grade, Size of Cable, meter, NR logo													

6.2.5 CONTROL CABLES

The control & instrumentation cables shall be multicore, colour coded, annealed stranded high conductivity copper, single conductor, insulated with PVC insulation, PVC sheathed, conforming to IS 1554 (Part I & II) / IS 7098 Part 1, relevant IEC. The outer sheath is of specially formulated PVC compound which will give the following properties: -

Oxygen - Index Min. 29,
 Smoke density - Min. 40% light transmittance,
 Acid gas - Max. 20% by weight,
 Flame propagation - Shall meet IEC 60332-1, IEEE 383.

Cables for use in the tunnel shall be low-smoke, non-halogenated type and FRLS type.

6.2.6 MODBUS CABLE

Communications cable suitable for Modbus RS-485 providing a master / slave communication between intelligent automation devices, controllers and FLTA wireless interfaces.

6.2.6.1 These shall have following minimum features:

- a) Outer sheath Low smoke halogen Free
- b) Insulation material polypropylene
- c) 22 (7) multi - paired AWG Tinned copper conductor
- d) Individual Aluminium foil screen 100% coverage
- e) Individual tape polyester each pair Overall tape polyester
- f) Cores twisted into pairs, pairs laid up
- g) Polyethylene insulation
- h) Drain wire 24 (7) AWG Tinned copper conductor
- i) Working voltage 300 V
- j) Velocity of propagation 66%
- k) Temperature range - 20 deg C to +80 Deg C Nominal conductor resistance < 53 Ohm per kilometre
- l) Insulation resistance > 200 M Ohm.M
- m) Characteristic Impedance 50 Ohms
- n) Capacitance Core to Core 98 pF/m
- o) Capacitance core to screen 180 Pf/m
- p) Nominal velocity of propagation 66%

6.2.6.2 Relevant standards to be complied:

- a) Low smoke generation: EN 61034 - 2
- b) Halogen Gas Emission: EN 60754 - 1&2
- c) Flame retardant: EN 60332 - 1 - 2
- d) RoHS2 compliant: Yes
- e) CE complaint: LVD(2014/35/EU), CPR (305/2011)
- f) CPR classification: ECA (EN50575: 2014+A1 :2016)

DATASHEET FOR MULTICORE CABLES

S.NO.	PARTICULARS	19Cx1.5	12Cx1.5	7Cx1.5	2Cx1.5
1	Make	as per approved makes			
2	Voltage Grade (kV)	1.1			
3	Type	Fire Survival Cable			
4	Reference Standards	BS 7846, IS 8130, IS 10462, BS 7655, IEC 60331, IEC 60332, BS 6387, BS EN 61034, IEC-60754			
5	Conductor				
(i)	Material	Stranded Annealed Tinned Copper Conductor as per IS 8130			
(ii)	Nominal Cross Section Area (sq.mm)	1.5	1.5	1.5	1.5
(iii)	Class of Conductor	Class-2			
(iv)	Shape of Conductor	Stranded circular			
(v)	2 layers of Glass Mica Tape applied over conductor	Yes	Yes	Yes	Yes
(vi)	Min. no. of strands	As per IS 8130			
(vii)	Max. DC conductor resistance 20 °C (Ohm/Km)	As per IS 8130			
(viii)	AC resistance at 90 °C (Ohm/Km)	As per IS 8130			
6	Insulation				

S.NO.	PARTICULARS	19Cx1.5	12Cx1.5	7Cx1.5	2Cx1.5
(i)	Material	XLPE			
(ii)	Nominal thickness of insulation(mm)	0.6	0.6	0.6	0.6
7	Core Identification	For 2 cores: Red & Black, For 3 cores: Red, Yellow, Blue. For 7 cores & above: White color cores with number printing on cores.			
8	Screening/ Shielding	The laid up Cores shall be screened with Aluminium Mylar/ Polyester tape (min. thickness 0.028 mm) with 100% coverage & min. 20% overlap. ATC Drain Wire of 0.5 Sq.mm (7/0.3 mm), shall be provided under Al- Mylar tape in continuous touch with Aluminium side of the tape.			
9	Inner Sheath				
(i)	Material as per BS 7846 : 2000	Extruded LSZH compound			
(ii)	Min. Thickness (mm)	as per BS 7846 : 2000			
10	Armouring				
(i)	Material as per BS 7846 : 2000	Single Layer of Galvanized steel Round Wire			
(ii)	Nominal Dia of armour wire (mm)	as per BS 7846 : 2000			
11	Outer Sheath				
(i)	Material as per BS 7655	LSZH Compound Type LTS-1			
(ii)	Min. Thickness (mm)	as per BS 7655			

6.2.7 CABLE CONDUITS

Cable conduits shall consist of stainless steel, material no. 1.4401 and shall be free of halogen. They shall be laid in accordance with the relevant standards. Those cables which run from the cable pit outlets along the tunnel wall to the safety equipment will run in conduits (control and power cabling).

These conduits shall be fixed with help of brackets and C-section rails on the wall. The material of these brackets, section rails and their fastening bolts shall be made of stainless steel, material no. 1.4401.

6.2.8 INSTALLATION OF CABLES ON WALL /INSIDE THE CONDUITS AS PER SITE REQUIREMENT

3 nos. 3 core, 11 KV copper cables shall be laid all along the route forming two 3 phase circuits and one cable as standby. Each circuit is capable to carry full design load of the tunnels as per load summary sheet.

11 KV cables in the tunnel are proposed to be laid on the wall / tray/inside the conduit as there is a space constraint in cable trench as per requirements for respective tunnels.

The 11 kV cable laying configuration on the wall / inside the conduit of the tunnel & actual fixing arrangement (with cover) will be applicable to suit site condition as per recommendations and approved by the Engineer.

6.2.9 CABLE JOINTS & TERMINATIONS

All joints and terminations shall be of the heat-shrink type, manufactured and tested to meet the requirements of IS-13573-2/3, IEC-60502-2/4 & IEEE48 standards to latest versions. Material used for construction of a joint/termination shall perfectly match with the dielectric, chemical and physical characteristics of the associated cable. The material and design concepts shall incorporate a high degree of operating compatibility between the cable end joints. The Straight through joint kit or termination kit shall be complete with all accessories, jointing material, insulating stress control and sealing material, lugs, nuts, bolts etc. as well as an instruction booklet explaining the method of using the kit. In case of heat shrinkable type kit, the joint shall include a heat shrinkable dual wall tubing which shall be insulating from inside and semi conductive from outside. Detailed sectional views of the assemblies shall be submitted along with the offer.

The cable termination kit shall be suitable for terminating the cable on indoor or outdoor installation as per requirement. The type of cable will be armoured XLPE insulated H.T/L.T. Cable. The straight through joints should be absolutely impervious to the entry of water. The manufacturer shall use the proven technologies and design to ensure a construction which will prevent entry of water or any other liquid inside the straight through joint and cable

6.2.9.1 Heat Shrinkable Straight Through Joints for MV Cables

The heat shrinkable straight through joints shall have following function abilities:

- a) For encapsulation, environmental sealing set of heat shrink outer insulating tubes with hot melt adhesive coating is required to be provided.
- b) To reduce stress over conductor, heat shrinkable stress control tube to be provided. The stress control tube has to be in electrical contact with the outer insulation screen of the cable. Impedance of the tube shall be constant up to an operating temperature and shall be within the range 1×10^8 ohm-cm to 8×10^8 ohm-cm and with Relative permittivity shall be minimum 15. Voids filling and stress relief over crimped connector and cut point of the insulation screen to be provided with void filling and moisture sealing high permittivity yellow mastic and lubricant.
- c) For joining of main conductor cores suitable size of ferrules/mechanical connectors with range taking feature should be provided. The cross-sectional area (CSA) of the ferrule/mechanical connector shall not be less than CSA of the conductor of the cable.
- d) Earth Continuity between armour to be provided by tinned copper braid of adequate cross section. This is required for proper earthing of the joint. Also, to support armour wire supporting is to be provided. The material of support ring to be steel (G.I.) for 3 core Cable
- e) For cleaning of cores, removing burrs on ferrules & rough insulation sufficient quantity of cleaning solvent & aluminium oxide cloth is required to be provided.

6.2.9.2 Heat Shrinkable Termination for MV Cables

- a) The cable termination (Indoor & Outdoor) shall be of Class-I type which consist of following points:
 - i. Stress control layer
 - ii. Resistance against UV light environmental protection
 - iii. Moisture seal-for environmental sealing against ingress of moisture & aggressive gases.
- b) To protect the cable breakout mono-plast tape is required to be applied.
- c) For proper sealing of Lugs at end of the termination suitable size & length of Heat Shrinkable tube is to be provided.
- d) Suitable size of heat stress control tubes is to be provided to reduce stress at cut back of scree. Void filling yellow mastic is to be provided at semi-conducting screen. Heat shrinkable anti tracking tubes are to be provided to cover bare XLPE insulation and to provide UV resistance & environmental sealing.
- e) For cleaning of cores, removing burrs on ferrules & rough insulation, sufficient quantity of cleaning solvent & aluminium oxide cloth is required to be provided. Adhesive tapes to be provided in sufficient length for marking on cables.

6.2.10 The Scope of this work also includes: -

- a) Supply, Laying, testing & commissioning of PE DWC/HDPE pipe 160/75 mm type 750N pipes as per RDSO Spec. No. RDSP/SPN/204/2011 with latest amendment & as per IS 16205 Part-24 for cables including along with all accessories like bends, couplers, etc. as required.
- b) Excavation and refill of 0.50 mtr. Width, 1.20 mtr. Deep trench and Hard trench in all kinds of soil/ Hard surface for laying of HDPE/DWC pipe for underground cable crossing. Contractor will clear all metallic part & stones etc. after cable/pipe laying contractor will clear all site, refilling by available soil and ramming the same to make good in same level and same quality.

6.3 EMERGENCY POWER SUPPLY ARRANGEMENT (DG SETS of 900/910 kVA Capacity)

One no of 11 KV DG set shall be installed in each substation. DG sets must be automatically start direct coupled engine- alternator assembly mounted on rigid fabricated steel base frame with resilient anti-vibration mountings complete with but not limited to engine, alternator, exhaust piping (as per CPCB norms) with silencer to provide at least 25 dBA insertion loss, electric starting equipment including batteries and battery chargers, acoustic enclosure, auxiliary system, AVR, AMF panel with protection and metering equipment, etc. connected to the 11 KV panel through cables.

- a) The DG sets shall be kept outside the tunnel at portals substations to prevent unsafe conditions inside the tunnels due to fuel handling and exhaust fumes. The DG set terminal voltage has been chosen as 11 KV since the system bus at portal substation is at 11 KV.
- b) Diesel engine shall be turbo-charged, multi-cylinder, electronic fuel injection cold starting with speed variation within 2% for load between 10% and 100%, with positively pressurized lubricating oil with engine driven lube oil pump, low lube oil pressure sensors and potential free contacts for conveying the signal to SCADA system, sensor and alarm for high jacket- cooling water temperature with suitable potential free contacts for conveying the signal to SCADA system, speed control mechanism with automatic fuel oil supply cut-off system for stopping the engine. Also, the engine shall be adequately protected against operating under overload conditions either by fixed overload limit stop on the fuel pump rack control rod or an alternate reliable mechanism to prevent the DG set being subject to a load exceeding the site rating plus 10% complete with potential free contacts for conveying the signal to the SCADA system.
- c) The DG set shall be silent type in each substation in the covered but naturally ventilated area with adequate exhaust piping planning (as per latest CPCB norms) and comply generally to IS:13364-Part 2:1992(R2018).
- d) The 11 KV DG set shall be complete with cooling system, fuel system, lubricating system, air intake system, exhaust system as per latest CPCB norms, governing and speed control system, standby system, engine protection safety system with microprocessor based power control command generator set monitoring, metering, protection and control system to meet demands of engine driven generator sets.
- e) The alternator shall be brushless, rotating field design alternator voltage 11 kV, power factor 0.8, with voltage regulation $\pm 0.5\%$ for all loads between no load to full load conditions of insulation with sound proof enclosure, weather proof enclosure Prime Power Rating (PRP) conforming to ISO 8528 part - I as per environment noise level norms 75 Db (decibels) as at one meter.
- f) The alternator shall be self-excited, self-regulator, self-ventilated in brushless design processed with suitable AVR and shall conform to BS:269, BS:5000, IS/IEC 60034-1 2004 and shall give rated output at NTP conditions.
- g) One number free standing 990 liters Day Fuel tank shall be provided with each DG set fabricated from GI /stainless steel sheet with inlet, outlet connections, air vent tap, drain plug and level indicator (gauge) GI/copper/stainless steel. fuel piping from tank to engine

with valves, unions, reducers, flexible hose connection and floor mounting pedestals, twin fuel filters and fuel injectors. The location of the tank shall depend on standard manufactures design.

- h) Foundation should be designed considering safe bearing capacity of soil. Anti-Vibration Mountings (AVMs) should be provided to reduce vibration transmission to the surrounding structure.
- i) Deleted.
- j) Deleted

6.3.1 TECHNICAL DATASHEET FOR 910 KVA DG SET

GENERATOR SET SPECIFICATION	
Duty	Prime
Power Rating kVA	900/910 KVA
No. of Phases	3
Output Voltage and Frequency (kV and Hz)	11 kV, 50 Hz
Power Factor	0.8 (lagging)
Current (A)	48
RPM	1500
ENGINE SPECIFICATION	
Make	As per approved make
Model	as applicable / EQU approved
Certified Power (hp)	1069
Required Power for Rated kVA (hp)	1069
Cooling	Liquid cooled (Distilled Water +DCA2)
Aspiration	Turbocharged After-cooled
No. of cylinders	12, Vee arrangement
Bore (mm) x Stroke (mm)	159 x 159
Compression ratio	16.7:1
Displacement (litre)	38
Fuel	High Speed Diesel
Fuel consumption @75% load with radiator and fan* (litre/hr)	151.22

Fuel consumption @100% load with radiator and fan* (litre/hr)	192.55
Performance class of generator set	ISO 8528-5 G2
Starting system	suitable DC battery supply
Lube oil sump capacity, High-Low level (litre)	140 - 114
Total lubrication system capacity (litre)	155
Lube oil consumption @ full load** (litre/hr)	0.28

6.3.2 TECHNICAL DATASHEET FOR ACOUSTIC ENCLOSURE FOR DIESEL GENERATORS

1	DG Set Capacities	900/910 KVA
2	Structure	MS Press bend 2 mm
3	Panels	Steel Fabricated double wall insulated panel
	Thickness of panels	100 mm thick
	Outer Sheet	2 mm thick CRCA sheet steel
	Inner Sheet	1.25 mm thick CRCA perforated sheet steel
	Frame & Strainer	2 mm thick CRCA sheet steel
4	Insulation	Mineral Wool as per IS 8183 – 1993
	Thickness	100 mm thick (50 mm x 2 slabs)
	Density	64 Kg / m3
	Anti-Droning	HDPE sheet
	Thickness	6 mm thick
5	Air Circulation System	Axial flow fans of suitable capacity required for DG set offered
6	Finishing	Powder coating of color shade approved by consultant/ owner
7	Noise level	75 DBA at a distance of 1 meter
8	Location	Outdoor
	Painting of Exhaust Piping	High Temperature aluminium paint shall be used (600- 700 deg C) for painting of uncladed exhaust pipe and top of the chimney
	Base Frame for canopy	Powder coated as per approved color.

6.3.3 AUTO MAINS FAILURE (AMF) PANEL/ AUTO SYNCHRONIZING PANEL: -

The AMF panel shall be capable of starting DG set automatically in the event of unhealthy conditions of main power supply including power (MAINS) failure, single phasing or voltage going below 85% of bus bar of main panel and shall switch over essential load from main power supply to DG set. The DG set will start automatically within 10 seconds of main supply failure. The synchronising logic shall be achieved through MICRO PROCESSOR based circuitry to monitor engine control, with an online MIMIC giving status. The generator set shall be capable of starting and taking up the load with-in-time stipulated in data sheet. The DG set will have protection / annunciation system conforming to latest standards like BS/ IEC or IS with soft control and torch resets shall be designed comprising complete protection/ annunciation requirement (overload, high temperature, alarms, earth fault, low battery voltage, fault indication alarm, fuel low level, metering indication etc.) The DG sets AMF panel shall be provided with interface for remote monitoring by SCADA (*from OCC*). The sequence of operation of synchronization of DG sets and Utility power, and NGR panels' operation with Transformers and DG sets neutral are as per standard.

6.3.4 TECHNICAL DATASHEET FOR NGR & NIS PANEL WITH VACCUM CONTACTOR

NEUTRAL GROUNDING RESISTOR PANEL		
1.0	SYSTEM DESIGN DATA	
1.1	Design Ambient	50°C
1.2	Reference Standards	IEEE-C57.32:2015
1.3	Rated Voltage	11 kV
1.4	Location of NGR	Outside
1.5	Resistance per resistor element	As per requirement
1.6	Material for resistor element	
i)	For high value of current	AISI-304, ASTM-A240
ii)	For low value of current	AISI-406
1.7	No. of parallel path	Two
1.8	Max. allowable temperature rise (over ambient) of resistor element	300°C - 350°C
2.0	ENCLOSURE	
2.1	Material and thickness	Sheet steel of 2.0 mm
2.2	Degree protection (as per IS2147 of 60529) /IEC-	
i)	Enclosure	IP-55 with canopy
ii)	Terminal Box	IP-55
3.0	SUPPORT INSULATORS	
3.1	Material	Porcelain
3.2	<i>Rated Voltage for 11 kV NGR</i>	<i>12 kV</i>
3.3	<i>One-minute voltage</i>	<i>power frequency</i>
3.4	<i>Creep-age Distance</i>	<i>25 mm / kV</i>
4.0	<i>PAINT / FINISH</i>	
4.1	<i>Paint</i>	<i>Powder Coated or epoxy painted as per specification. Synthetic enamel shade 632 as per IS-5</i>

5.0	MOUNTING STRUCTURE	
5.1	Material	Hot dip galvanized standard steel section
5.2	Thickness / deposit of galvanization	75 Microns / 610 g/m ²
6.0	TERMINAL CONNECTION	
6.1	Type	Bushing
6.2	Material	Porcelain
6.3	Rated Voltage	11 kV
6.4	One minute power frequency dry withstand voltage	75kVp/28kV r.m.s.
6.5	Creepage Distance	25 mm / kV
6.6	Connection neutral between NGR & Transformer	Tinned Copper Flat

Neutral Grounding Register (NGR) and Neutral Isolating Switch (NIS) Panel shall be provided with each DG set. The NIS cubical houses the isolating switch (Manual as well as motorised) and CTs as per design. Contractor shall submit the complete design for Engineer's review.

6.3.5 AUTOMATION SYSTEM

The EPC contractor shall ensure that following operations of DG will be controlled and monitored through SCADA.

- a) Stop/Manual/Auto switch along with potential free contacts for monitoring the manual operation status (wherever applicable), to be provided for that equipment whose start/stop is controlled by SCADA Automation System.
- b) Potential frees 'NO' contacts for monitoring 'RUN' status of equipment wherever required.
- c) The installation of current transformer & transducer along with wiring between current transformer & transducer up to the terminal block shall be provided by the Contractor. All transducers shall be supplied by SCADA contractor in future.
- d) Provide all necessary relays, contactors, current & potential transformers required by SCADA system. CT's for SCADA system shall be of 15 VA rating and of metering class. Also, adequate space in the panels shall be provided for mounting of electrical transducers as required.
- e) The low voltage SCADA cables shall be brought up to AMF panels by SCADA contractor and all terminations into AMF panels shall be made by Generating set contractor after satisfying himself of the wiring system. It is to be clearly understood that the final responsibility for the sufficiency, adequacy and conformity to the contract requirements, lies solely with the Generator Contractor. The following (but not limited to) shall be monitored through SCADA *from OCC*:
 - i. Radiator temperature at each generating set.
 - ii. Start / Stop each Transfer pumps.
 - iii. Status monitoring for oil transfer pumps
 - iv. Duplicate monitoring of each indication as given in annunciation window of AMF panel

- v. Battery voltage status.
- vi. Voltage, current, power factor, frequency and power consumption monitoring at each generating set.

Auto / Manual / Stop changeover switch shall be provided by the contractor for each mechanical equipment related to generating sets with potential free contacts. For the temperature monitoring, all nipple / sockets in the pipe shall also be in scope of contractor.

6.4 TUNNEL LIGHTING: -

6.4.1 GENERAL

This covers the complete Tunnel Lighting System for the tunnel, consisting of tunnel lighting and emergency lighting including control, all required equipment, materials, and accessories. The detail drawing of **power supply arrangement** (Indicative) is attached in section VII-II: Tender Drawings and Documents.

This includes SITC of following Panel/ DB's: -

- a) Lighting SDB (Day time lighting) Threshold-1 and Threshold-2 1100x200x1200 mm, IP 54 stainless steel (AISI 316)
- b) Lighting DB with 1 no. incomer (63A, FP, MCCB) from Main LT Panel, Copper Bus bar (433V, TPN, 63A) and 10 nos. outgoing feeders (6-16A, FP, MCB) including 2 nos., 3nos. or 4nos. spare feeders, IP54 stainless steel. (AISI 316)
- c) Lighting DB with 1 no. incomer (63A, FP, MCCB) from Main LT Panel, Copper Bus bar (433V, TPN, 63A) and 14 nos. outgoing feeders (6-16A, FP, MCB) including 2 nos. spare feeders, IP54 stainless steel (AISI 316)
- d) Lighting DB with 1 no. incomer (63A, FP, MCCB) from Main LT Panel, Copper Bus bar (433V, TPN, 63A) and 18 nos. outgoing feeders (6-16A, FP, MCB) including 2 nos. spare feeders, IP54 stainless steel. (AISI 316)
- e) Lighting SDB, 700x200x1200 mm, IP 54 stainless steel (AISI 316)
- f) Main UPS Panel with 1 no. incomer (80A, TPN, MCCB) from UPS, Copper Busbar (433V, TPN, 80A) and 6 nos. outgoing feeders 16A - 63A, TP MCB) including 2 nos. spare feeders, IP 55 stainless steel (AISI 316)
- g) UPS SDB, 700x300x1200 mm, 12 Outgoing panel, IP 54 stainless steel (AISI 316)
- h) Main UPS Panel with 1 no. incomer (160A, TPN, MCCB) from UPS, Copper Busbar (433V, TPN, 160A) and 18 nos. outgoing feeders 16A - 63A, TP, MCB) including 4 nos. spare feeders, IP 55 stainless steel (AISI 316)
- i) UPS Lighting DB with 1 no. incomer (63A, FP, MCCB) from Main LT Panel, Copper Bus bar (433V, TPN, 63A) and 6 nos. outgoing feeders (6-16A, FP, MCB) including 2 nos. spare feeders, IP54 stainless steel (AISI 316)
- j) Maintenance SDB with 1 no. incomer (32A, FP, MCCB) from Maintenance power socket DB, Copper Busbar (433V, FP, 50A) and 6 nos. (16A, DP, MCB) outgoing feeders including spare feeders, IP 54 stainless steel (AISI 316).

- k) Maintenance DB with 1 no. incomer (63A, FP, MCCB) from Main LT Panel, Copper Busbar (433V, TPN, 63A) and 4 nos. outgoing feeders (32A, FP, MCB) including 1 no. spare feeders, IP 54 stainless steel (AISI 316)

6.4.2 VALUES AND DEFINITIONS

Regular lighting inside the tunnel for service, maintenance works and for rescue reasons shall be provided. The lighting system consists of LED lamps. The lighting is partitioned in individual sections. Each section contains normal supply and UPS power supply. All normal and UPS supplied sections shall be connected.

6.4.2.1 Level-1, Round the Clock / emergency illumination (10 lux minimum or as per latest guideline issued by RDSO/Railway Board)

20 watt LED luminaries shall be fixed at every 24 meters (or as per lux level calculation to maintain minimum lux level inside the tunnel) distance on each of the side walls of the tunnel at a height of 2.5 meter from the walkway level. These luminaries are connected with UPS power supply. After every two normally power supplied luminaire (maintenance), there is a UPS supplied luminaire. As per NFPA-130, these luminaries shall give minimum illumination of 10 lux (or as per latest guideline issued by RDSO/Railway Board) throughout the tunnel round the clock.

6.4.2.2 Level-2, Reading and Maintenance illumination (27 lux minimum or as per latest guideline issued by RDSO/Railway Board)

2 nos. 20 watt LED luminaries shall be fixed at equal distance of 8 meters between two round the clock luminaries on each of the side walls of the tunnel at a height of 2.5 meter from the walkway level. Normally these luminaries shall be off and shall be switched on only when maintenance and inspection work is carried out. These luminaries will be on separate circuit, supplied by normal power supply. These luminaries along with round the clock luminaries shall give a minimum of 27 lux illumination.

6.4.3 Day / Night Time Lighting

The day time lighting has been designed in two zones (Threshold zone: 1 & Threshold zone: 2) at lux level of 350 lux Avg. and 180 lux Avg. respectively for both entrance and exit portal of each tunnel. Day and night time luminaries are connected through two different circuits. The Night time luminaries at spacing of 24 meter (10 lux) are connected through UPS circuit which will remain on round the clock while Day time luminaries are controlled through photometer sensor / timer. These photo sensors sense the outdoor lighting intensity and weather conditions for switching ON / OFF/ control of luminaries through SCADA system.

6.4.4 Day time Lighting Design

A. Tunnel Portal Entrance

- i. Threshold Zone 1 (TH 1): Zone Length – 100 Meters, Lux Level – 350 lux Avg. *(from 0-100 m at the entrance)*
- ii. Threshold Zone 2 (TH 2): Zone Length – 100 Meters, Lux Level – 180 lux Avg. *(from 100-200 m at the entrance)*

B. Tunnel Portal Exit

- i. Threshold Zone 1 (TH 1): Zone Length – 100 Meters, Lux Level – 180 lux Avg.
(from 200-100 m from the exit)
- ii. Threshold Zone 2 (TH 2): Zone Length – 100 Meters, Lux Level – 350 lux Avg.
(from 100-0 m at the exit).

6.4.5 Emergency Tunnel Lighting

The emergency lighting allows illumination while the main power supply has broken down. Therefore, each third lamp of the Tunnel Lighting System shall be supplied from UPS power which is also known as round the clock lighting. Emergency lighting allows safe walking on the walkway path throughout the tunnel in case of evacuation. During abnormal conditions (e.g. fire alarm) the lights must remain switched ON.

6.4.6 Main Tunnel Cross Passages / Adits Lighting/pathway Lighting

Detailed specifications of luminaries shall be as per Northern Railways (NR) CEE Spec No: CEE/NR/121-Elect/PS/2019(REV-04) Dated-04.11.2019 or latest for LED light specification. The cross passages/ Main tunnel/pathway luminaries shall fulfil following conditions:

Degree of protection: IP 66 (as in the main tunnel tube) – IP 66

Impact Resistance: IK 10

Protection class: II

Luminaire: 1 X 20 watt LED

Installation of Luminaries: T

The LED Luminaires in the cross passages shall be fixed below the cable trays. A distance of 8 m spacing on the both sides of the wall.

The lighting in the Accesses will be switched ON, if:

- i. A fire is detected, automatically
- ii. The doors of the air locks will be opened, automatically
- iii. By the tunnel operator, manually
- iv. By the tunnel's maintenance personal, manually with switch on-site.

6.4.7 LIGHTING CONTROL

Tunnel lighting shall be controlled from the control units in SCADA control room of substation at Sonapat end. The tunnel lighting system shall be compatible to SCADA in future. Additionally, it shall be controlled by switches at the substation E&M niches as applicable.

6.4.8 POWER SUPPLIES – SPECIFICATIONS**OPERATIONAL INFORMATION**

Supply voltage - 240 V a.c.

Supply frequency - 50 Hz

Output - SCADA

Maximum output current - 235mA per Line

Ambient temperature - 0-50° C

Relative humidity - 0-90% non- condensing

Mounting - Surface

TESTS: The LED, LED driver and luminaries shall be tested with the applicable IS/IEC reference standards.

6.4.9 TECHNICAL SPECIFICATIONS - GENERAL 433 / 240 V – 50 Hz POWER SUPPLY

The general power supply of the 433 / 240 Volt-level to the different equipment occurs from the main power supply from substation to the Electrical Niches as applicable and then further to the ultimate equipments.

In the tunnel the distribution of the energy occurs from the both substation to electrical Niches and then further to the ultimate equipments. All power and control units shall be installed into distribution panels, all different voltages (e.g. Main power, UPS power, safety extra-low voltages, different control units and so on) shall be placed in separated or comprehensive different distribution panels. Grounding and protection cables shall be coloured yellow-green as per standards compliance. The inlet of the cables into the distribution panel generally shall be made from bottom with a degree of protection of IP 54 in Electrical Niches and Service Buildings / control room. The Niches also shall have cable inlets on top. This is necessary to lay the cables from the Niche to the cable tray along the tunnel wall. Switches, push buttons, pilot lamps and measuring instruments shall be installed into the distribution panels' front doors. All electrical equipment, inside a distribution panels / boards shall be labelled. Also, the distribution panels themselves shall be labelled with a combination of letters and numbers, which shall be engraved into an aluminium-plate. Equipment inside the tunnel, measuring instruments, etc. shall be labelled with stainless steel-boards. Each distribution panel shall be provided with a pocket for the drawings, this pocket shall be fixed on the inside of the distribution panel's door (fixed with screws or rivets, the use of glue is not allowed). All distribution panels shall be grounded. Distribution panels shall have lightning arrestors/ surge protection device to protect all facilities from voltages higher than 433 V. All distribution panels, situated in the main tunnel, as well as in the cross passage shall be equipped with anti-condensation heating. Circuit breakers and fuses shall be discriminating to each other facilities (discriminating ratio) in direction of the power / current flow. The contractor is obligated to offer a system which shall be installed without any structural alteration.

6.4.10 Central Connection Element:

All control and data cables shall be connected with the central connection element, this shall be a distribution panels equipped with terminals for jumpering the cables and relay units for order multiplexing. All data shall be available at the central connection element, this element shall be at the central data exchange location of the tunnel site (substation / control room) and the SCADA system shall be connected to this.

6.4.11 MAIN LT PANEL & DISTRIBUTION PANELS

All wiring and cabling inside the panels shall be laid in GI-ducts. All metal parts which are not under voltage shall be GI/stainless steel. All incoming and outgoing cables with a cross section equal to or less than 25 mm² shall be based on terminal boards and shall have strain relief devices. For cable centres at distribution panels with degree of protection of IP54 cable glands shall be used.

All cables with larger cross sections shall be directly connected to the particular electrical equipment inside the distribution panels. If the cross section of the cables is although too high for connecting with the electrical equipment, nevertheless terminals for reducing the cross section shall be used. Terminal strips shall be provided with a numbering-system. The strips shall be labelled. All incoming and outgoing cables also shall be labelled (number of cables, starting position and destination).

The internal wiring, cabling and bus bars in the panels and small accessories to follow the function and regulations, like coverings, top-hat rails, C-profiles, GI/stainless-ducts, screwed conduit entries, etc. shall be calculated in the position of the distribution panels. Light-current parts installed in panels shall be suitable for a mounting on top-hat rails or Profiles and respectively in 50 mm racks / as applicable.

Each distributor which will carry electrical equipment, which is provided for mounting at 50 mm frames, shall have 50 mm swing frames or 50 mm fixed frames / as applicable. The height of those frames depend on the height of electrical equipment which shall be installed on it, and the height of distributor. Depending on the thermos technical requirement, the distribution panels shall be equipped with ventilation openings with grids. The degree of protection shall be observed for standards compliance.

The contractor shall provide enough mounting rails for all devices and equipment which shall be installed inside the distribution panels. All equipment shall be accessible.

For cable entries at distribution panels with a degree of protection of IP 54 cable glands shall be used. The Electrical Panels shall be a minimum of Form 4b Type 5 separation in accordance with BS EN 61439-2/IEC 61439-2 for Main LT Panel and Form 3b separation as per IEC 60439 for Distribution panels.

Each distribution panels shall be equipped with 1 lock (incl. key). The lock shall be fixed at 3-points at each door of distribution panels (on the top, on the bottom and in the middle of the doors). The 3 fixed points shall be connected with one rod/ latest version as applicable for distribution panels of reputed manufactures of approved make. The maximum height of panel shall be 2400 mm. with maximum height of operating handle be 1800 mm. from bottom. The termination height shall be 300 mm (minimum).

6.4.12 JUNCTION BOX:

Cable junction boxes shall be used for normal and emergency equipment's (lighting, power, control circuit) conforming to IP66 with intrinsic fire resistance & insulation integrity (E90) complete with cable glands suitable for the connected cable.

Application area

- Day time lighting, night-time lighting, accentuating light, inside main tunnel.
- cross passage lighting inside the tunnel.
- Functional integrity E90 junction boxes for fire alarm system.
- Emergency communication or telecom box inside the tunnel.
- Functional integrity E90 junction boxes for operating the emergency exhaust and smoke extractor.

For Lighting, the junction box is required for reducing the cable's cross section, if they are higher than 4 sqmm, and for dividing the main supplier cable into the individual single feeders for the lamps. They shall be made for through-wiring in a 3-phase system with maximum wiring diameter of 4mm², feeder cable to luminaries is a single feeder cable 3x2.5 sqmm. The lighting cables shall be FRLS with min. functional integrity E30. the junction box shall also be with E90 resistance integrity. The junction boxes shall be equipped with compressed synthetic cable glands suitable for the connected cables.

6.4.12.1 JUNCTION BOX SPECIFICATION FOR EMERGENCY EQUIPMENT'S

The junction boxes (JB) shall be made of sheet steel material with IK 10 impact resistance having no toxic or corrosive resistance. The junction box shall comply and test certificates for intrinsic fire resistance accordance with DIN 4102 part 12 together with function retaining cables. The junction box shall comply to IEC 60670-22 for requirement, as per connecting boxes & enclosures. The JB shall be complete with screw anchors for external wall fixing and connecting terminals made of high grade ceramic and resistant to high temperature. The sheet steel junction box shall be power coated & suitable earthed.

Supply of **IP 66** cable boxes for emergency equipment (lighting, power and control circuits). The junction's boxes shall be made of Sheet **Steel Powder Coated material** and shall be Orange in colour **RAL 2003** having no toxic or corrosive emissions. The junction box shall comply and shall be tested for **intrinsic fire resistance accordance DIN 4102 part 12 (German standard)** together with function-retaining cables of 1.5 sq. mm to 16 sq. mm as specified. The junction box shall comply to **IEC 60670-22** for particular requirements for connecting boxes and enclosures. **The insulation integrity E90 of the boxes shall be BS EN 50200.** The junction boxes shall have included screw anchors for external wall fixing and connecting terminals shall be made of high grade ceramic and shall be resistant to high temperatures E90 and cable entries shall be with metric system.

The terminals will be 5 pole and shall be suitable for 1.5 sq. mm upto 16 sq. mm cable sizes, multi-level knockouts shall be provided for cable glands in different sizes. The material of construction used shall be free of halogen and junction box shall be insulated and shock-proof. In case of sheet steel, power coated, the box shall be suitably earthed. The junction boxes shall be used only with type tested cables for the functional integrity class E90 (Tested

with cables of approved make). The entire solution shall be tested in accordance with DIN 4102 part 12 for functional integrity and EN50200 for insulation integrity and the vendor shall submit the test report/certificate for the product from Exova laboratories or equivalent institute for fire safety.

6.4.12.1.1 TECHNICAL DATA SHEET FOR EMERGENCY JUNCTION BOXES

Materials	Sheet Steel
Degree of Protection	IP66
Degree of protection against mechanical load	IK 10
Fire Protection in the event of internal faults	<p>Minimum requirements:</p> <ul style="list-style-type: none"> -Intrinsic Fire resistance accordance with DIN 4102 part 12 together with function retaining cables. - 650°C for boxes & cable glands - 860°C for conducting components
Burning behavior	<ul style="list-style-type: none"> - Junction Box shall comply to IEC 60670-22 - Insulation integrity E90 of the boxes shall be BS EN 50200 - Intrinsic fire resistance / fire rated & insulation integrity (E90)
Toxic behavior	Halogen free, Silicon free, conform to RoHS directive 2002/95/EC

Chemical resistant	Acid, Lye, Petrol, Mineral Oil & partially resistant from Benzene
Rated Insulated Voltage	AC/DC 690V
Connecting Terminals	High grade ceramic resistant to high temperatures
Terminals	5 pole
Cable entries	Shall have option for cable plate
Protection Class	Class II, totally insulated

Type test certificate	Comply to IEC 60670-22 as per connecting boxes & enclosures
Mounting Type	Wall / floor mounting.

6.4.12.2 JUNCTION BOX SPECIFICATION FOR NORMAL EQUIPMENT :-

The Junction Box shall be insulated and made out of Polycarbonate with glass fibre reinforced. The Polycarbonate Junction Box shall be environment friendly, recyclable, UV resistant, halogen & silicon free, anti-acid & anti corrosive. The Junction Box shall be rated for Degree of Ingress Protection IP66 in accordance with IEC 60529. The gasket material shall be Polyurethane, and the gasket shall be internally embedded. The JB's shall be complying the standards IEC 60670 – 1, IEC 60670 – 22 & IS-13252. The manufacturer of Junction Box / Enclosure shall submit a copy of IEC Certificate.

For better safety the Polycarbonate encl. shall be fire retardant & self-extinguishing in accordance with IEC 60 695-2-1, DIN VDE 0304 Part 3. It should be tested at Glow Wire test for 960 deg. Cent. The impact strength of polycarbonate enclosures / boards i.e. the Degree of Protection against Mechanical load shall be in accordance with EN 62208: 2012 for IK 09. **Cable junction boxes with intrinsic fire resistance / fire rated & insulation integrity (E90).**

6.4.12.2.1 TECHNICAL DATASHEET FOR NORMAL JUNCTION BOXES

Materials	Thermoplastic Polycarbonate (PC-GFS)
Gasket	Internally embedded made of Polyurethane
Degree of Protection	IP66
Fire Protection in the event of internal faults	Minimum requirements: - Glow wire test in accordance with IEC 60 695- 2-11- UL Subject 94, IS-11000 - 650°C for boxes & cable glands - 860°C for conducting components
Burning behaviour	- Glow wire test in accordance with IEC 60 695- 2-UL Subject 94 at 960°C, flame retardant & self-extinguishing.
Degree of protection against mechanical load	IK 09 (10 Joule)
Toxic behaviour	Halogen free, Silicon free, conform to RoHS directive 2002/95/EC
Temperature resistant	-40°C to +120°C
Chemical resistant	Acid, Lye, Petrol, Mineral Oil & partially resistant from Benzene
Rated Insulated Voltage	AC/DC 690V
Cable entries	Shall have option for cable plate
Protection Class	Class II, totally insulated
Type test certificate	Should hold type test certificate with switchgear assemblies (TTA), according to IEC 60 439-1 (IS 8623)

Mounting Type	Wall / floor mounting.
---------------	------------------------

6.4.13 ELECTRICAL NETWORK PANELS

These Panels carry the components for network. The Network panels, installed inside the tunnel, are made of stainless steel of 316L grade. The dimensions of Network panels are as per standard or as per site conditions requirement for those situated in the Control Centre. The Network Panels will have a single door, to have only front accessibility for the Network equipment's installed. The Network Panels also have front panels made of glass, to see the electrical equipment inside. These will comply to IS standards.

6.4.13.1 **CIRCUIT BREAKER:** Circuit breakers shall have a rated breaking capacity of at least 36 kA / 50 kA at 433 VAC and a current limiting class 3. Some shall be executed inclusive switched neutral conductor (+N).

Residual-Current-Operated Circuit-Breaker: They shall be alternating current sensitive;

surge-proved up to 36kA / 50 Ka.

Residual-Current-Operated Circuit-Breaker with Integral Overcurrent Protection: They shall be alternating current sensitive; surge-proved up to 36kA/ 50kA; 2 or 4-pole switched and at least 1 or 3-pole protected (2 pole or 4 pole).

6.4.13.2 AIR CIRCUIT BREAKER

- a. ACB should be mechanically robust of compact moulded case design, air break horizontal and withdrawable type, conforming to IS / IEC / BS EN 60947-2. 24-240 V A.C shunt-trip coil shall be operable, within operational voltage range of 70% to 110% of rated voltage as per Clause 7.2.1.3 of IEC 60947-1.
- b) Maximum number of circuit breaker auxiliary switches, spare auxiliary switches to be equally divided between normally open and normally closed. Additionally, 4 spare pairs of N.O. and N.C. volt free contacts shall be provided.
- c) Indicating lamps for on, off, ready to close, tripped on fault with all necessary push buttons, panel wiring, bus wiring, terminals, fuses, etc.
- d) Power and control cable terminals with undrilled gland plates for outgoing power cables and multi-core cables.
- e) An interlock to prevent withdrawal when the breaker is closed.
- f) The automatic control shall be defeated when the selector switch is put at local or OFF position as per requirement.
- g) Remote indication and alarm facilities shall be provided for Circuit-breaker open, Circuit-breaker closed, Circuit Breaker is ready to close (UV release energized, Shunt release de-energized, spring charged, Breaker is not "ON", Breaker is not mechanically interlocked with other breaker and ACB is not racked in completely in service position) and Circuit-breaker tripped on fault.

- h) Automatic changeover and interlocking with the help of an external controller.
- i) Operation of emergency push button.

6.4.13.3 MOULDED CASE CIRCUIT BREAKERS (MCCB)

Moulded case circuit breakers shall be in accordance with IS: 2516 (Pt-I&II)/1977, IEC 60947, IEC 60664, IEC 61557-12 with degree of protection IP 20 and shall be of microprocessor based release having a quick break, quick make trips free mechanism and according to the relevant standards, which were mentioned herein. The electronic trip shall be adjustable.

The operating switch dolly shall provide a clear indication of "ON", "OFF" and "TRIPPED" positions and shall have provision for locking in the "OFF" position. They shall be equipped with time delay tripping on low overloads and high speed tripping on short circuits. Contacts shall be tipped and shall have a quick break and quick make wiping action. The case shall be moulded in non-hygroscopic material of arc resisting characteristics and shall incorporated- ionising type arc chutes.

MCCBs shall comprise a device, designed to trip the circuit-breaker in the event of high value short-circuit currents. This device shall be independent of the thermal-magnetic or electronic trip unit. The breaking will be carried out in less than 10ms for short-circuit currents above 25 In. MCCBs with ratings up to 250 A shall be equipped with fully interchangeable trip units in order to ensure the protection against overcharge and short-circuit. The trip units shall be either of:

- a. thermal-magnetic
- b. electronic

MCCBs with ratings over 250 A shall be equipped with electronic trip units. Electronic and thermal-magnetic trip units shall be adjustable and it shall be possible to fit lead seals to prevent unauthorised access to the settings

Thermo-magnetic trip units shall offer:

- a. Adjustable Thermal protection from 0.7 to 1.0 times the current rating.
- b. Fixed Magnetic protection for current ratings up to 200A.
- c. Adjustable (from 5 to 10 times the current rating) for current ratings greater than 200A.
- d. Adjustable (from 9 (or less) to 14 times) the current rating for magnetic only motor protection.

Electronic trip units shall offer:

- a. Electronic trip units shall be fitted with thermal memory
- b. It shall be possible to adjust basic protections with a knob without any power supply or when the main is off.
- c. It shall consist 2 LED for load indication, one lighted above 90% of I_r , and one lighted above 105% of I_r .
- d. A test connector shall be installed for checks on electronic and tripping mechanism operation using an external device.
- e. MCCBs shall be equipped with a self-test of the connection between the electronic trip unit, the current transformers and the actuator. The self-test will be of positive logic and visible through the flashing of a green LED in case the self-test occurred correctly and the extinction of the LED in case the self-test failed.

Each moulded case circuit breaker shall be equipped with auxiliary contacts to monitor its control state. An accumulated fault alarm (one per system, e.g. lighting, ventilation, etc.) shall be handed over to the SCADA system via local distributed unit and further to the PLC.

6.4.13.4 MINIATURE CIRCUIT BREAKERS (MCB)

Miniature circuit breakers shall be in accordance with a degree of protection IP 20 and shall be of magnetic and thermal trip type and according to the relevant standards of IEC 60898, IEC 60947, which were mentioned herein. For arc quenching, the breakers shall be equipped with magnetic blow out contacts.

Each miniature circuit breaker shall be equipped with an auxiliary contact to monitor its control state. An accumulated fault alarm (one per system, for example lighting, ventilation, etc.) shall be handed over to the SCADA system via local distributed unit and further to the PLC.

6.4.14 COMMUNICATION WITH CONTROL CENTRE

Following signals and control states shall be transmitted to the Control Centre by use of the Tele control system (SCADA). Therefore, all these signals and control states shall be based in / at the central connection element. Signals and control states to be transmitted are:

- a. Tripping of any isolating circuit breaker, moulded circuit breaker or miniature automatic circuit breaker, combined to one signal per network for niches substation / E & M Niches / E & M NICHEs (one signal for each distribution point and one for each network) for following but not limited to:
- b. Breakdown of the main power supply
- c. Power supply from the UPS
- d. Failure of the UPS
- e. Actual active power (kW) at the niche's substation / E & M Niches/ control room
- f. Transformers secondary voltage
- g. Cumulative fuse tripping
- h. as per data points (I / O points approved by Engineer).

Note: -The tunnel is situated in an area highly endangered by lightning and unstable power supply is expected. Therefore, all the electrical equipment installed shall have Over voltage protection, Under Voltage Protection and surge voltage protection as per standard and requirement.

6.5 PLUG SOCKETS & MAINTENANCE SOCKETS CABINET

The cabin of the plug sockets its size shall be about 200 x 178 mm (width x height) or as per drawing. The depth is about 150 mm or as per standard. The used material shall be stainless steel, material no. 1.4401, high-quality stainless-steel equivalent to SS-316L, degree of protection min IP 65. The Power Socket shall be made of High-quality Thermoplastic Polycarbonate (rust free, shock proof, corrosion free, fire retardant) with IP-67 protection, contact terminals made of high-quality copper alloy (brass) & all steel components (screws, springs, etc.) shall be zinc plated or nickel plated. The socket outlets shall be compatible to the rescue and maintenance equipment. Power sockets also shall be provided for emergency

and maintenance. These plug sockets shall consist of power sockets and standard electrical sockets. The power socket shall be supplied by standard power. In the Access-Tunnel, the plug socket and maintenance cabinets are different to those cabinets in the main tunnel tube. The ones in the Accesses shall not be equipped with plug sockets. These cabinets only shall provide space for spare / reserve. These plug sockets shall be provided every 50 meter on one side of tunnel wall having 3-Phase supply.

6.5.1 CABIN FOR PLUG SOCKETS, MOUNTED ON TUNNEL WALL

Housing: 260 mm x 210 mm x 168 mm (w x h x d) (max)

Material: Polycarbonate / Stainless steel Protection Class: min IP 65

The Maintenance Power Sockets should hold type test certificates as per IEC 60309, EN60529, DIN 4102-12. The Socket assembly should consist of proper Insulation bolt, Stainless steel screws / bolts and fasteners, MCB, Hinged Flap (optional), along with wiring accessories, Earth strips, Sleeves, etc. of standard specifications.

Single Phase Maintenance power socket should consist of 16 A DP 10 kA MCB with allowable cable sizing of 3Cx4 Sq.mm cable. Three Phase Maintenance Power Socket should consist of 16A FP 10 kA MCB with allowable cable sizing of 4Cx4 Sq.mm cable.

Allowable number of single phase sockets shall be 4 nos. and three phase sockets shall be 2 nos. per circuit or as per standard.

6.6 UNINTERRUPTIBLE POWER SUPPLY SYSTEM (EMERGENCY POWER SUPPLY SYSTEM): -

This covers the emergency power supply of all required equipment, materials, accessories, and all labour for the complete emergency power installation. All data required by the Control Centre shall be based at the central connection element. Contractor shall access the entire load for UPS and submit the same for Engineer's approval. If UPS of capacity more than 20 kVA is required than same shall be provided by the contractor and 20 kVA id the minimum capacity of UPS.

6.6.1 UNINTERRUPTIBLE POWER SUPPLY

The UPS units (Uninterruptible power supply) will be installed with two hours (120 minutes) autonomy period as required to guarantee that following plants/ equipments can be supplied power in case of main power failure:

- a. Tunnel emergency lighting
- b. Emergency call system
- c. Signs, escape route lighting and orientation signage, other sign guidance
- d. Public address & sound system (if Available)
- e. Integrated tunnel control system (SCADA)
- f. Other emergency requirement
- g. Fire detection and fire alarm system

The UPS system will be complete with inverter battery bank, rectifier charging unit, inverter units, protective devices, filter circuits, system static transfer switches/bypass switches, auxiliary equipments etc. All the characteristics of UPS (like THD, overload, etc.) shall be as per IEC/EN 62040.

The UPS has to be fed from the main power supply (433 V, 50 Hz) and shall supply the connected equipment via rectifier, battery and inverter.

In the event of a main power supply failure the equipment has to be fed from the battery and inverter system without any interruption.

The UPS shall be equipped inclusive bypass switch and an interface for Tele control System/ SCADA.

6.6.2 TECHNICAL SPECIFICATION (UPS COMPONENTS) BATTERY BANK

6.6.2.1 BATTERIES:

Sealed Maintenance-free (SMF) Lead-Acid Power Battery Voltage as required by the UPS-system. The battery capacity at all locations shall ensure supplying the full load for at least 120 minutes with elevated temperatures up to 40 Deg C. Batteries shall be of rugged design in order to provide a heavy-duty operation of at least 5 years with low internal resistance and minimal maintenance with minimal ventilation. Operational temperature range: + -5° to + 40° C with humidity up to 95% non-condensing

6.6.2.2 INTERCONNECTION BUS BARS:

The bus bars shall be made of copper according to the relevant standards, which were mentioned herein. Suitable size to provide a minimum voltage drop PVC clad to provide protection against accidental contact.

6.6.2.3 BATTERY STANDS / RACKS:

The batteries at the substation & control room shall be mounted on GI/stainless steel racks to provide a compact arrangement, with easy installation and access for servicing.

The racks shall be made of steel with electro statically deposited powder coating.

The coating shall be resistant against acid, saline and highly resistant against scratching and / or impact. All other required materials shall be highly resistant against environmental conditions as experienced in battery rooms .an electric ventilation and climate shall ventilate the battery room in niches substation/ control room as applicable. The complete air shall be changed a minimum of six times per hour. The acid proof tiles shall be provided on the floor and on all the walls upto height of 1.5 meter.

The ventilation has to be realized with all required facilities like ducts, louvers, installation of the fan with a switch beside the door. All wall ducts shall be closed and covered after the

ventilation is installed. The ventilation to comply with international / IS standards as per site requirements.

6.6.2.4 RECTIFIER / CHARGER UNIT

This unit has to be equipped with output current limiting, whereby the maximum output current shall be limited to 125 % of the nominal output current rating. The UPS unit shall have ammeter and voltmeters to indicate both charging and mains current / voltage and amps meter to indicate rate of charge and discharge of batteries. This current limit shall be adjustable from 100 % up to 125 %.

The output filter shall minimize the ripple of the current in the batteries. Under normal conditions the ripple of the current in the battery shall comply to 3 % RMS.

The filter shall be adequate to ensure that the DC output of each rectifier / charger shall meet the input requirements of the inverter.

The UPS shall have the capability of operating the inverter directly from the rectifier with the batteries being disconnected.

Quick charging equipment shall be capable of charging fully discharged batteries within six hours.

Input: 0.433 VAC, 3-phase, 4 wire, 50 Hz

INVERTER UNIT

Input: Output from the rectifier / charger unit (batteries).

Output: 433/ 240 V sinusoidal AC.

Maximum of total harmonic distortion: +/- 1 % at power factor 1 from No-load operation to full load. 50 Hz +/- 1 % at power factor 1 from no-load to full load.

Maximum dynamic Voltage deviation: +/- 5 % during power failure and +/- 10 % during major load change Recovery to a maximum deviation of +/- 3 % within 50 ms and to +/- 1 % within 100 ms.

Total harmonic Distortion: 2.5 % maximum

The rectifier shall be able to operate 10 minutes at 125 % overload at unity power factor after the working temperature has been stabilized at the nominal workload. Under normal conditions, the surrounding temperature will not exceed + 25 °C. A self-protecting current limiting circuit shall limit the inverter output to 125 % of the rated load or respectively in case of a short circuit. UPS system should consist of integrated Surge protection circuit.

Constant synchronisation of the oscillator shall define the converter frequency and its stability during stand-alone operation. During normal operation, the inverter shall be synchronised by

the main supply. In case of mains failure or frequency-deviation larger than +2 % / -1 %, the inverter shall automatically switch-over to its interior oscillator.

Upon return of main supply, resynchronisation shall be started automatically. Resynchronisation at full load and / or full voltage shall be achieved within 30 seconds.

The deviation from 50 Hz shall never exceed +/- 1 Hz. The power semiconductors of the inverter shall be fused with fast blowing fuses to prevent cascading failures.

Each fuse shall be controlled by fuse monitoring circuit leading to an indicator light on the UPS's control panel as well as to a common fault indication.

6.6.2.5 PROTECTIVE DEVICES AND FILTER CIRCUITS

A DC (direct current) smoothing equipment shall enable the system to achieve a total harmonic distortion, which isn't larger than 2.5 % RMS of the output. Protective devices shall avoid any damage or failure on the UPS caused by excessive overload, short circuits, surges, high voltages caused by lightning activity and/or other conditions.

6.6.2.6 DC CIRCUIT BREAKER

The UPS shall contain a DC circuit breaker. If open, the battery shall be completely disconnected from the rectifier / charger and the inverter.

6.6.2.7 SYSTEM BYPASS SWITCH

The UPS system shall be by-passed automatically in case of overload.
The static switch detection and transfer time shall not exceed 5 ms.

6.6.2.8 STATIC TRANSFER SWITCH

The static transfer switch shall be equipped with a manual selector switch to allow manually controlled switching between the UPS and the bypass source for maintenance and service purposes. The static transfer switch shall be rated higher (power, respectively current) than the inverter current limiting rate and shall have a short circuit current and time rating equivalent to the fault level of the bypass source at the static transfer switch. Control interlocks shall be provided in order to prevent the inverter from being manually switched back to the essential bus (main power) without synchronisation.

6.6.2.9 ISOLATING TRANSFORMER

In-built Isolation transformers should be provided for galvanic isolation and are used to protect against electric shock, to suppress electrical noise in sensitive devices, or to transfer power between two circuits which must not be connected.

6.6.2.10 AUXILIARY EQUIPMENT

- a. Emergency flash light with battery charger installed in the battery room.
- b. All facilities required for handling of acids and gasses.

- c. Warning notices concerning the handling of the whole UPS system in English and Hindi language.
- d. Working instructions for UPS Warning notices and working instructions shall be in two separate and properly indicated pockets on the inside of the UPS switchboard as well inside the battery room. Cable dimensioning shall be in accordance to the relevant standards and shall have a diameter that the voltage drop is not more than 4 % to the nominal voltage from the transformer to the furthest supplied electrical facility. Also, the cables shall have such a diameter that, if there is a short circuit at the furthest point to the circuit breaker, the circuit breaker cuts off without the cable exceeding its rated temperature.

6.6.2.11 MAINTENANCE

The emergency power supply shall be designed for continuous reliable operation such that the "Mean-Time-Between-Failures" (MTBF) for individual modules of the UPS through the rectifier / charger unit, inverter unit and static switch etc., shall be more than 80 000 hours. To ensure a minimum down-time, the "Mean-Time-To-Repair" (MTTR) of the emergency power supply shall not exceed 24 hours for the UPS.

The MTTR shall be the time, excluding travel time, required to diagnose the fault and restore the emergency power supply to normal working condition by means of modular replacement at the tunnel site. The travel time must not exceed 12 hours to keep down time to bare minimum.

6.6.2.12 TECHNICAL DATASHEET FOR UPS (20 kVA)

	SPECIFICATIONS	REQUIREMENT
1	TECHNOLOGY & CAPABILITY	
	UPS should have its own DSP controller and contains a full rated rectifier, full rated inverter and battery charging circuit	
	UPS should be with inbuilt Isolators for Input, Output, static & maintenance bypass.	
	There should be isolating transformer at UPS output.	
	Integrated Surge Arrestor must be included in UPS system.	
2	INPUT	
	Input facility -Phases / Wires	3-Phase / 4-Wire & Ground (R, Y, B -Phases & Neutral + Ground)
	Input Voltage	433 V AC
	Nominal Input Frequency	50 Hz
	Input Frequency	50 Hz \pm 3%
	Input Power Factor	0.9 on rated load
	Generator Compatibility	Compatibility to genset supply required
3	OUTPUT	
	Nominal Output Voltage	380 / 400 / 433V AC (Selectable)

	Output Voltage Regulation	+/- 1%
	Nominal Output Frequency	50 Hz
	Output Frequency Regulation	+/- 0.05 Hz (Free Running / Self Clocked Mode) + / - 5 % (Synchronized to Mains Mode, Selectable)
	Output Frequency Slew Rate	1 Hz / s
	Output Wave Form	Pure sine wave
	Output Voltage Distortion	<=2.5% (For 100% Linear) <= 5 % (For 100% Non-Linear)
	Crest Factor	3: 1 On Full Load
	Unbalanced load on phases	100% unbalanced load should be allowed
	Voltage symmetry with 100% Unbalanced Load	+/- 2 %
	Displacement angle for 100% balanced Load	120 deg +/- 2 deg
	Transient Response / Recovery	
	Dynamic Regulation for 0% to 90% step load	+/- 5 %
4	EFFICIENCY (at nominal voltage & Resistive load upto KW rating of UPS)	
	Overall Efficiency (AC to AC) – Online	>85 % @ 100 % load
5	Alarms	
	Audible Alarms	Mains Failure / Battery Low Alarm / UPS Overload / Fault / Shutdown / Charger Fails Alarm / Battery High / Battery Temperature Cut off Alarm
6	Battery Backup / Battery Bank & Charger	
	Backup Required	2 hours (120 minutes)
	Battery Bank V Ah (Vendor to include battery sizing calculations with tender)	
	Batteries Type	Inbuilt Sealed Maintenance Free (SMF) Lead-Acid batteries- 12V Cells
	Minimum Charger Rating (Including internal / external)	10% of Battery Ah rating offered

hanger type / Charging Method & Charging Voltages	Constant Voltage Constant Current Solid state SMPS charger designed for at least 10% of Battery Ah offered Float Voltage: 2.25 VPC Boost Voltage: 2.32 VPC
Battery recharge time (After complete discharge) to 90% capacity	8 to 10 hours to 90% capacity
Quick Charge System	6 Hours after complete discharge of system (optional)
Battery Housing (Vendor to provide the GA drawings of the offered Battery open Rack)	
Battery End Cell Voltage	1.7 V / Cell
Interfaces	
Serial Communication Port	RS232: Should be provided as standard
REPO (Remote Emergency Power Off)	Provided in-built in the UPS
Interface to SCADA System	Modbus Card for connecting to UPS to SCADA through RS485 & monitoring thru SCADA
Restart / Testing Capability	
Automatic Restart	UPS should start up automatically on mains resumption after battery low shutdown
Battery Self-Test	Manual / Scheduled battery test to ensure healthiness of batteries. However, in event of weak batteries, test should be aborted and fault reported to the user thru replace battery warning
Physical	
Operating Temperature	0 to 40 deg C
Storage Temperature	-25 to 55 deg C
Operating Humidity	0 to 95% RH (Non-condensing)
Ambient Relative Humidity	20% to 80%
Operating Altitude	< 1000 m above sea level
Protection Class	IP – 20

Type of Cooling	Forced Air
Noise Level	< 65 dbA at 1 meter distance
Form Factor	Free Standing Floor Mounted UPS
Dimension (w x d x h) in mm	To be furnished by the vendor
Weight - in kg	To be furnished by the vendor
Packaging Material	Recyclable (No CFC)
Connections - Rectifier Input / Output / Bypass Input / Battery	Hardwired
Conformity and Standards	
General and safety requirements for UPS used in operator access areas	EN50091-1-1/IEC62040-1-1/AS 62040-1-1/IS-16242 (Part-1):2014
Electromagnetic compatibility (EMC) requirements for UPS	EN50091-2/IEC62040-2/AS 62040-2 (C3) /IS-16242 (Part-1):2014
Method of specifying the performance and test requirements of UPS	EN50091-3/IEC62040-3/AS 62040-3 (VFI SS 111) /IS-16242 (Part-1):2014

6.6.2.13 Deleted

6.7 Escape Route Orientation sign and Fire Extinguisher glow signage

These signs indicate the escapees the direction of escape route into the cross passage or out of the tunnel. Those signs shall be mounted at both sides of the main tunnel. The signs shall fulfil following conditions: -

Degree of protection: min. IP 65

Protection class: II

Static symbol: LED ≥ 200 cd/m²

Dynamic symbol: LED with minimum 5 arrows for each direction

The escape route indication is giving escape route orientation with signs which are installed throughout the entire tunnel and shall increase the level of visibility of the escape route during fire.

Therefore, the escape route orientation signs shall be mounted in a distance of 50 meters or as per standard on both tunnel walls (next to the railway track and walkway path) throughout the tunnel at a height (lower edge) of 1 m above the path respectively the rail track.

The escape route indication shall consist of two parts; the upper part is a static sign which is illuminated by LED-lamps and shows an escaping person. The lower part of the sign shows flashing LED-arrows which shall display the direction (north or south) of the escape route by flashing.

Dimensions of the static symbol (h x w), approx.: 400 x 400 x 80 mm (h x w x d)

Dimensions of the LED symbol (h x w), approx.: 150 x 400 x 80 mm (h x w x d)

The dimensions are approx. values only; they can vary depending on the manufacturer.

The luminance of the static part of the symbol shall be ≥ 200 cd/m².

The controlling of the escape route orientation signs shall be realized by a main control unit. This control unit shall be placed in the control room.

In emergency case the distributed I/O Unit in the control Room shall transmit the data to the Escape Route Orientation Sign Control Unit (EROSCU), which shall switch on the signs with the correct direction. Every escape route orientation sign shall be adjusted separately with determined patterns. For example, when the pattern "one" will be activated, all signs will be switched on and the LED symbols shall display the direction "right". The pattern "two" indicates the direction "left". The escape route orientation signs also shall have the function of indicating both directions simultaneous. The contractor shall design the program of the sign in accordance with Engineer. (when/ which directions are shown).

The data connection from the EROSCU to the signs shall be realized by OFC (optical fibre cabling).

6.7.1 ESCAPE ROUTE SIGNS

The illuminated signs (escape route orientation-, emergency- and escape route sign) shall be illuminated with LEDs.

- a) Degree of protection: IP 65
- b) Luminance: ≥ 200 cd/m²
- c) Housing material: Stainless steel (material No. 1.4401 = "AISI 316"), thickness 2 mm, with powder coating. The swing-out bezel shall be fixed with hinges made of stainless steel
- d) Support: Stainless steel (material No. 1.4401)

6.7.2 EMERGENCY SIGN

This sign indicates the people the situation of an emergency telephone. Those signs shall be mounted above all panels.

The signs shall fulfil following conditions:

- a) Degree of protection: min. IP65
- b) Protection class: II
- c) Static symbol: LED ≥ 200 cd/m²
- d) Dimensions: approx. 470 mm x 470 mm
- e) Front sheeting: on both side(s) 3 mm Acryl glass with emergency telephone
- f) Symbol, dimensions and colours according to Indian standards.

6.7.3 Visibility Sensors

Visibility is monitored in Infrared units with necessary reflector which monitor the density of smoke between the IRU and the reflector. It indicates the % level/status of visibility to present values on SCADA station. Alarm will sound in the control room along with indication when visibility falls below the present prescribed limit.

6.7.3.1 Technical Data of Visibility Sensors

a) Features Parameters

- i. Measuring units' ppm for CO & NO, m-1 or m for visibility
- ii. Path Length - 3m (6m folded beam)
- iii. Calibration - Automatic zero calibration - manual span check by check cell
- iv. Measurement - Visibility (Opacity)
- v. Measurement Technique – Optical Transmissivity
- vi. Measurement range - 0.015 m-1
- vii. Accuracy - ± 0.0002 m-1
- viii. Resolution -- ± 0.0001 m-1
- ix. Response Time - 10 sec to 2 min.
- x. Analogue outputs - 3 x 4-20mA current outputs as standard, isolated, 500 Ω maximum load.
- xi. Relay Outputs - 3 x volt-free SPCO contacts, 50V/1A maximum load, configurable as alarm contacts
- xii. Communications Port - RS485 interface
- xiii. Power supply - to be derived from available UPS supply
- xiv. Construction - Corrosion resistant epoxy coated aluminium housing sealed to IP65

b) Calibration Accessories:

Flow Through Check Cell - CO/NO span check using bottled audit gases
Check Cell - Visibility span check optical cell

- c) Temperature Sensors:** -Tunnel temperature monitoring equipment are used for monitoring the tunnel ambient temperature with sensors placed at suitable locations inside the tunnel. When the tunnel ambient temperature rises beyond a pre-set limit (>40°C), an audio-visual alarm shall be activated in the control room as per site requirement.

6.8 SITC OF STAINLESS STEEL CABLE TRAY (LADDER AND PERFORATED TYPE) : -

The cable tray in the tunnels will mainly be used to carry the power cabling of the tunnel's safety equipment. If necessary, also the control cabling of safety equipment shall be laid in the cable tray. Following size of cable tray will be in the scope of work but not limited to: -

- 6.8.1 SITC of Stainless Steel Cable Tray for HT and LT cables, Ladder type of size 150 x 50 x 2 mm thick**, wall mounted on suitable supporting arrangement, throughout the tunnel and both side of wall tunnel made of material no. 1.4404, continuously connected including reducers, tees, coupling plate and nut bolts, washers, etc. made of stainless steel material no. 1.4401 conforming to specifications complete as per requirement.

- 6.8.2 SITC of Stainless Steel Cable Tray for Lighting cables, Perforated type of size 150 x 50 x 2 mm thick**, wall mounted on both sides on suitable supporting arrangement, throughout the tunnel, made of material no. 1.4404, continuously connected including reducers, tees, coupling plate and nut bolts, washers, etc. made of stainless steel material no. 1.4401 conforming to specifications complete as required, as per the specification.

The cable tray shall be mounted on the tunnel wall, next to the walkway path side. In front of the EM-Niches, the cable tray shall be mounted on the ceiling (height of down-hanging between 150-200 mm). The height of lower edge shall be as per standard. For fixing the cable tray on the tunnel wall, substructures shall be needed. The substructure shall have a L-profile and shall be made of one piece.

The cable trays shall consist of U-section sheets made of stainless steel, material no. 1.4401, with a width as per Engineer approval. The fixing arrangement (including support arm/ angle) shall be "hot dip galvanized heavy duty steel".

Note: -

- 1. The Contractor should refer cable tray size for reference only. Detailed size and fixing arrangement shall be furnished by EPC contractor after award of work for approval by Engineer.**
- 2. The contractor will have to ensure that the HT and LT cable is placed on separate trays.**

Depending on the used cable tray, expansion joints shall be required. These expansions joints shall be included in the price of cable tray. The fastening bolts for mounting the substructure on the tunnel wall also shall be made of stainless steel, material no. 1.4401.

Each Cable tray section should be properly connected to the adjacent trays to maintain the earth continuity of the cable tray. The cable tray's substructure normally shall be mounted in a span of about 1.0 m / as per drawing. Due to the fact that in the areas of Electrical Niches and of the Access-Tunnel, the cross section of tunnel is different to the other sections, so there the cable tray cannot be mounted in a height of 3.5 m lower edge. The cables shall be laid along the tunnel wall up to upper edges of Electrical- Niches. For leading the cables along the tunnel wall there, cable ladders shall be used.

The substructures of the cable trays above the Electrical-Niches and cross passage have to be different to the remaining tunnel. That means, the substructures shall not be mounted at the tunnel walls, but hanging down from ceiling, above the walkway path side.

The material also shall be stainless steel. The length of the suspension is determined as per standard.

The EPC contractor has to guarantee, that the cable tray shall be laid in one level.

6.9 ELECTRIFICATION OF SUB-STATION AND OTHER SERVICE BUILDING/ROOMS WITH ALLIED FACILITIES

- a) Wiring for light/ceiling fan/exhaust fan/call bell etc. points including circuit wiring, sub-main wiring with Fire Retardant (FR), XLPE insulated, multistranded, copper conductor (3x1.5sqmm,3x2.5sqmm,3x4sqmm and 3x6 sqmm single core cable) on surface/in recessed PVC conduits, distribution boards, sub distribution boards, earthing and suitable number of modular switch & socket and single phase/ Three phase DB complete in all respect as per requirement specification and standard Railway practices. Cables/Wiring shall be laid down in metallic/rigid fire resistant PVC conduits. PVC conduits shall be used in concealed wiring only.
- b) SITC of LED tube light fittings, LED flood light fittings, ceiling fan, Exhaust fan with lower shutter and other Electrical equipment as per requirement and standard Railway practices.
- c) SITC of 150 Ltrs water cooler – 01 Nos and 1.5 Ton heavy duty, 5-star inverter type split air conditioner with required suitable size nuts, bolts, fasteners, cu pipe & petty hard ware in all respect. Top up the required refrigerant & maintain the pressure (If required) as per company recommendation or latest Eco-friendly refrigerant for Control room or any other service building as per decision of Engineer.

6.10 NEW CONNECTION OF ELECTRIC POWER SUPPLY (3 PHASE, 11 KV) FOR BOTH SUBSTATIONS OF HORC TUNNEL AND ALL ASSOCIATED WORKS:

Reliable Electrical Power Supply (3 phase, 11 kV) for both sub-stations (Separate feeder circuit for each substation) of tunnel and associated works including all liaison work from State DISCOM. The Contractor shall assess the load requirement and connected load of each substation after load calculation for each tunnel and obtain approval of the Engineer for getting new connection.

The cost Include (for each substation) copper cable laying/Overhead Line with H-pole

from DISCOM substation to HRIDC HT panel, Metering arrangement, protection, earthing connection of DISCOM end and connection at HRIDC substation including payment for application fees, charges etc. for 2000 kVA load for each substation. Necessary clearance from statutory authorities.

6.11 DESIGN, SUPPLY, INSTALLATION, TESTING AND COMMISSIONING OF EARTHING SYSTEM BY USING OF: -

- a) The earthing shall be done with 3 meters long 50 mm dia. 'B' class G.I. Pipe earth electrode with 12 mm dia. holes around the pipe at distance of 30 cm, downside tapered. Earth electrode to be put vertically 3-meter-deep with alternate layer of salt & charcoal approx. 50 kg charcoal and 10 kg salt. 8 SWG hot dip G.I. or 7/4 mm dia. galvanized steel stranded earth wire shall be connected from earth electrode top with 12 mm dia. G.I. nut bolt to main board / equipment with masonry / RCC earth enclosure of size 300x300x300 mm (In side to inside) with I25 mm wall thickness & suitable size MS/RCC pull out cover. The G.I. wire shall run in 12 mm 'B' class G. I. Pipe along with wall / pole up to height of 1.5 meter. The depth of 8 SWG hot dip G. I. or 7/4 mm dia galvanized steel stranded earth wire including connections from earth pipe to main board / equipment /H pole etc in ground shall be 30 cms.
- b) Supply, Erection and commissioning of maintenance free earthing (chemical to enhance earth bonding improving compound) using 80 mm Dia. Copper earth electrode of tube/ rod of 3 Mtr. Length including inspection chamber, CI funnel with 20 gauge G.I wire mesh, RCC chamber 300X300 mm with concrete base, Cast Iron / heavy plate manhole cover with frame.
- c) Supply, Installation, testing & Commissioning of Copper Bonded Steel Earth Rod of 3-meter length, 17.2 mm dia with Exothermically welded busbar along with 50 kg Earth Enhancement Compound in each pit. With pit covers made up of Poly plastic with SITC of 10 mm Copper Clad Steel Round Conductor laid at 600mm below the ground, as per specification and code of practice.
- d) SITC of Earthing Grid of 11/0.433kV portal substation: -

An earthing grid with a combination of 17.2mm dia. horizontal copper bonded steel earth conductor and 17.2 mm dia. 3 meter length vertical copper bonded steel rod conductors along with 50 kg Earth Enhancement Compound and exothermic welding joints shall be laid in a grid foundation layout of 15x6 meter at a depth of 0.5 meter below the ground for 25kA of fault current at each substation. Both substation of 11/0.433kV shall be interconnected with each other using 150 sq. mm Copper Clad Steel Stranded Conductor. This conductor shall be laid throughout the tunnel. The calculations shall be done as per IEEE 80:2013. The earth resistance for the portal/external **station grid shall be less than 1 ohm**. The interconnection of 11/0.433 kV grid shall be done using 150 sq. mm copper bonded steel conductor along with ISG.

Note: - Earth resistance value of each type of earth should be within limit and as per standard issued by RDSO/Railway Board.

6.11.1 EARTHING DESIGN FOR ELECTRICAL SUBSTATION AT CENTER OF TUNNEL

Two isolated maintenance free earth pits with 17.2mm dia, copper bonded steel rod of 3-meter length along with 50 kg Earth Enhancement Compound shall be installed for Transformer Neutral in order to avoid floating Neutral. For Transformer Body two separate earthing pits shall be installed with same specification and both these pits shall be interconnected with the main earthing conductor (150 sq.mm) coming from the portal stations.

For PLC Panels, an Isolation Spark Gap shall be connected before connecting it through the main earthing busbar.

6.12 SUPPLY & INSTALLATION OF EARTHING AND POTENTIAL EQUALIZATION SYSTEM FOR INSIDE TUNNEL WITH CROSSINGS

6.12.1 Earthing Design for Main Conductor and Equipment Installed In The Tunnel: -

A stainless steel conductor main potential equaliser of 150 sq. mm shall be laid through the overall length of the tunnel on both the sides. At every crossing, the conductor on the opposite sides shall be interconnected with each other for equi-potential bonding. Also, an equi-potential bus-bar shall be installed at every crossing, which will again connect through these conductors. All the electrical equipment shall be connected to these bus-bars for the earthing and equipotential bonding.

For the tunnel body earth, the EPC contractor needs to leave a point at every crossing for connecting the reinforcement of the tunnel with the earthing conductor for proper equipotential bonding and for cathodic protection. The tunnel body reinforcement earthing shall be provided at every 200 m at both the tunnels. Contractor shall ensure from calculation that the reinforcement earthing at every 200 m is safe and if spacing of less than 200 m is required then less spacing shall be provided.

All equipment, which is placed outside of the tunnel also shall be included to the potential equalization.

All metal constructions, although they are not current-carrying, for example cable trays, E & M niches, distributors, doors and others shall be included to the potential equalization.

The fire main also shall be connected with the earthing system at every 100 m or as per standard. The insulation of these potential equalization connections in the tunnels in the niches shall be free of halogen or as per design requirement. The connections of earthing and bonding shall be stud- or clamp-type. These requirements shall apply irrespective of

the operating voltage and purpose of the equipment. All necessary suppression chokes / filters shall be included and shall be capable of withstanding fault conditions. All cable shields shall be bonded together and connected to the ground rod. Particular attention shall be paid on the correct bonding and grounding of single core cable shields.

The design of the system shall include protection against lightning, all effects of stray current and else due to faults in adjacent circuits, which may cause damage or incorrect performance of the equipment.

6.12.2 Potential Equalization Bus Bar/ Main Earthing Terminal (MET):

In Niches potential equalization bus bars shall be erected. The materials of the bus bars are:

Main Tunnel Tube (E & M NICHE, etc.): Tinned Copper

Cross passages: Tinned Copper

Buildings (Control Centre): Tinned Copper

The bus bars shall be insulated (this shall be calculated into the price of the PE bus bars).

6.12.3 Electrochemical Reaction:

A connection of two different metals, affects by electrolytes (e.g. tunnel wash water), causes a chemical reaction. To avoid these reactions, precautions have to take place. If required, the connections to the potential equalization bus bars shall be made with a two-metal conductor, for avoiding electrochemical reaction. Before the contractor connects the potential equalization to the earthing, he shall measure the resistance of the earthing. Metallic pipes, conduits and cable tray sections for cable installation shall be bonded to ensure electrical continuity and connected to earthing conductors at regular interval. Apart from intermediate connections, beginning points shall also be connected to earthing system.

6.12.4 Tinned Copper MET:

Copper earth terminal 500mm long and 50mm wide and 6mm thickness with 8 no. of factory drilled holes mounted inside the enclosure boxes, for terminating incoming / outgoing earth conductors mounted with nylon insulated supports with brass threaded inserts, entire assembly supported on galvanized steel channel suitable for mounting on tunnel wall / Electrical niche wall. Suitable disconnecting link(s) shall be provided to facilitate earthing measurement. A transparent enclosure shall be given for more protection.

6.12.5 LIGHTNING PROTECTION SYSTEM SCOPE:

The scope of work under this section covers the Engineering / Design, supply, installation, connection, testing and commissioning of lightning protection system. The lightning protection system shall be designed and installed as per IS / IEC 62305 and additional requirements (if any) of this specification. General arrangement of the

protection system shall be as indicated in the drawings and consisting of the following:

- Air termination network.
- Down conductors.
- Joint and Bonds.
- Conductor Holders
- Expansion Piece
- Testing Links.
- Earth termination network.

CODES AND STANDARDS:

The Component and accessories covered by this specification shall be designed, manufactured and tested in compliance with the latest relevant standards published by the Indian Standards institution wherever available in order that specific aspects under Indian conditions are taken care of.

The Component and accessories for which Indian Standards are not available shall be designed, manufactured and tested in accordance with the latest and relevant IEC.

The component and installation shall also conform to the latest Indian Electricity Rules and requirement of Indian Electricity Act. Nothing in this specification shall be constructed to relieve the Contractor of his responsibilities.

Generally, the Lightning protection system shall conform to IS/IEC: 62305 unless otherwise stated. Following standards shall also be applicable: -

- | | |
|-------------------------------------|---|
| • IS/IEC 62305-1
: | Protection against lightning – General Principles. |
| • IS/IEC 62305-2
: | Protection against lightning – Risk Management. |
| • IS/IE 62305-3
C: | Protection against lightning – Physical Damage to the structure and life hazard |
| • IS/IEC 62305-4
: | Protection against lightning– Electrical and system within structure |
| • IEC: 62561-1
– | Lightning Protection components

Requirements for connection components. |
| • IEC: 62561-2
– Requirementsfor | Lightning Protection components

conductors and earth electrodes. |
| • IEC: 62561-3
– Requirementsfor | Lightning Protection components

isolating spark-gaps. |
| • IEC: 62561-4
– Requirementsfor | Lightning Protection components

conductor fasteners. |

- IEC: 62561-5 Lightning Protection components
– Requirements for Earth electrode inspection housing and earth electrode seals.
- IEC: 62561-6 Lightning Protection components
– Requirements for Lightning strike counters.
- IEC: 62561-7 Lightning Protection components
– Requirements for Earth enhancement compounds.
- NBC – 2016 National Building Code 2016

EXTERNAL LIGHTNING PROTECTION SYSTEM:

- i. As air terminals shall be installed on the highest roof of the building, the air terminals shall be joined to horizontal roof conductor by means of proper clamps & connectors.
- ii. Roof conductor shall be laid horizontally on the roof.
- iii. Down conductor shall be installed on the vertical surface of the building. The down conductor shall be joined with roof conductors in the method as prescribed by the code.
- iv. The down conductor shall be joined with earth termination network or to the earthing station as indicated on the drawing.
- v. At every 1 mtr, the roof conductor holder for mesh and wall conductor holder for down conductor should be used.
- vi. At every 20 mtr, an expansion piece should be connected in order to avoid unnecessary contraction and expansion of conductor due to change in weather conditions.
- vii. At the connection of the earth-termination, a test joint should be fitted on each down conductor.
- viii. A test joint shall be provided in the down conductor 1000 mm above the ground level at a place which is easily accessible for testing.

COMPONENT / PARTS:

Vertical Air Terminal at Portal Stations

The probability of structure penetration by a lightning current is considerably decreased by the presence of a properly designed air-termination system as per IS/IEC 62305 and NBC 2016.

Air termination systems can be composed of any combination of the following elements-

- a) Rods (including free-standing masts)
- b) Catenary Wires
- c) Meshed Conductors

The individual air-terminations rods should be connected together at roof level to ensure current division.

Vertical air terminals shall be provided for the Air Termination network, at the highest points, corners, and edges and at connection to down conductor, as per approved drawing. The Contractor shall co-ordinate the installation detail to allow for bonding of the network with the external façade elements, to comply with the

requirement of IEC 62305-

3. All fixing accessories, installation materials etc. as required, shall be included in the Contract. Roof mounted electrical/electronic equipment (for example, chillers, antennas, cameras etc.) need vertical air-termination to avoid direct flashover.

All metallic projections, ducts, vent pipe, railings, gutters etc., on or above the main surface of the roof of the structure shall be bonded to and form part of the air termination network.

The air terminal of 15 mm dia., 1 meter length made up of copper bonded steel material shall be installed at every corner of the building.

Horizontal Conductor/ Mesh Conductor

Copper bonded steel conductor of 8mm (min.) dia. can be used. The conductor shall be made of high tensile low carbon steel, molecularly bonded with copper on outer surface to comply the requirements of IS/IEC 62305. The minimum thickness of copper bonding shall be 250 microns.

The conductors shall be installed at locations in compliance with the code requirement and as per approved Drawings. The conductor and Air terminals shall be securely fixed in place with suitable clamps and hardware, to the building structure. The clamps / hardware used for jointing Air terminal to the roof conductor and for fixing of roof conductor to the metallic / Masonry / glass surface of facade, shall be according to the relevant part of IS/IEC 62305.

Wherever possible, the horizontal conductors shall be of continuous lengths. Where saddled to masonry the fixing screws shall be set in expansion type plugs contained in properly formed holes. All roof conductors are to be secured by roof conductor holders at intervals of 1000mm.

Drawings showing the various roof levels of the building indicating the general arrangement and layout of the air termination system. The Contractor shall ensure that air termination system, installed over its total route of the roof shall maintain absolute electrical continuity. Provision shall be made with suitable fittings to allow for expansion and contraction of the horizontal conductors at every 20 meter.

Down Conductor:

The Down Conductors shall be in compliance with the IEC 62561-2. Copper bonded steel rods of 8mm (min.) dia. can be used. The rod/ conductor shall be made of high tensile low carbon steel, molecularly bonded with copper on outer surface to comply the requirements of IEC 62561. The minimum thickness of copper bonding shall be 250 microns.

The down conductor shall be distributed around the outside wall / façade of the structure. Minimum Spacing between the down-conductors shall be as per designed level of protection and as per IS/IEC 62305-3. Down-Conductors are to be secured at intervals of 1000mm.

Any external metal running vertically through the structure shall be bonded to the down conductors. A down conductor shall follow the most direct path possible between the air terminals and the earth termination. Separation distance needs to be calculated and maintained from live parts/services while routing the down-conductors.

At the structures, which cannot be punctured for holding the down-conductors, like

tin roofs, glass façade etc., the down-conductors should be supported with adhesive type clamps tested for weather durability, wind speed and for withstanding lightning currents as per designed Lightning Protection Level.

Joints and Bonds/ Connectors

- a) The lightning protection system shall have minimum joints as possible. Joints and bonds shall be mechanically and electrically effective. Joints exposed to the atmosphere/open air can be clamped, screwed, bolted, riveted or exothermically welded joints. Joints and bonds made below earth and in concrete shall be through exothermic welding only.
- b) With overlapping joint, the length of overlapping shall not be less than 25mm for all types of conductor. Contact surfaces shall be first cleaned, and then inhibited from oxidation with a suitable non-corrosive compound. Joints of dissimilar metals shall be protected from moisture by an inert, tenacious material.

Fixing Accessories/Conductor Holders

Suitable fixing accessories to be considered to support Roof conductor as well as down conductor at every 1 meter as per IS/IEC 62305-3. The fixing accessories and the conductor holders shall be complying IEC 62561.

Lightning Strike Counter

The Lightning systems shall be installed complete with the lightning strike recorder. The lightning strike recorder shall contain a mechanical 6-digit display which will register all lightning discharges. The lightning strike recorder shall be housed in an IP 67 rated enclosure and operate without reliance on batteries or on any other external power source.

Test Clamp

Each down conductor shall be provided with a testing joint in such a position that, it is convenient for testing (about 1000 mm above Ground level). It shall be made of copper and shall be connected at every down conductor for connection and disconnection purpose.

Earth termination Network

The resistance from any part of the lightning protection system to earth shall not exceed 10 Ohm before any bonding has been affected to metal in or on a structure or to services below ground. If the value obtained exceeds the specified 10 Ohm it shall be reduced by adding to the number of earth electrode.

An earth termination network shall consist of vertical and horizontal conductor comprising of ring earthing at a min. distance of 3.0 meter from the structure.

6.12.6 Isolation Spark Gap (ISG):

An isolation spark gap shall be used with every transformer neutral at substations and with every PLC & SCADA Connection when connecting them with a common Earthing

Grid. Also, when interconnecting 11/0.433kV station, an ISG shall be installed. Inside the tunnel also, at every crossing the ISG shall be considered with PLC panels, Transformer Neutrals and with other sensitive equipment.

Note: -

- a) All materials used in the work shall be procured from RDSO approved sources or ISI marked only and of the best quality and of the class suited for the purpose specified.
- b) Design codal life of all type of material/equipment should be as per RDSO codal life standard.
- c) The contractor shall be solely responsible for the correctness of the position, levels and dimensions of the works according to approved drawings, notwithstanding that he may have been assisted by the Engineer or his men in setting out the same.
- d) Notwithstanding anything given anywhere else all work execution shall be as per latest design and drawing of RDSO and latest guideline issue by Railway Board.
- e) The contractor should follow all the clearances as per latest CEA regulation.
- f) Meet the all protective provisions relating to electrical safety.

XXXXX

Tender No. HORC/HRIDC/C-4/2022

Attachment 8 to Corrigendum No. 3

Section VII-8: Tender Drawings and Documents

A- Tender Drawings

Revised and New Tender Drawings

Section VII-8

A: Tender Drawings

List of Drawings



-Black colour shows Tender drawings which have not been revised in Corrigendum No.3



-Blue colour shows Tender drawings which have been revised in Corrigendum No. 3



-Red colour shows New Tender drawings added with Corrigendum No. 3

Notes:

1. Tender Drawings are available for downloading on HRIDC website under Active Tender Section (<https://hridc.co.in/active-tender.php>).
2. Only revised and new drawings added after issue of Corrigendum No. 2 are attached in this Corrigendum No. 3

S. No	TITLE	DRAWING NO.
1 CONCEPTUAL PLAN AND LONGITUDINAL SECTION:		
1.	Conceptual plan and longitudinal section from chainage 10.0KM to chainage 15.185KM (tunnel)	GC-HRIDC-ALL-DRW-ALN-P&P-10-15KM_A1
2.	Conceptual plan and longitudinal section from chainage 15.185KM to chainage 20.0KM	GC-HRIDC-ALL-DRW-ALN-P&P-15-20KM_A1
3.	Conceptual plan and longitudinal section from chainage 24.0KM to chainage 30.0KM (tunnel)	GC-HRIDC-ALL-DRW-ALN-P&P-24-30KM_A1
2 TUNNEL		
1.	Conceptual drawing for Single track tunnel cross section (Rock)	GC-HRIDC-C4-DRW-TTL-CLT-01001_A1
2.	Conceptual drawing for Single track tunnel cross section (Soil)	GC-HRIDC-C4-DRW-TTL-CLT-01002_A1
3.	Conceptual drawing for Support class III from CH: 24940 to CH: 26000	GC-HRIDC-C4-DRW-TTL-CLT-01003_A0
4.	Conceptual drawing for Support class IV from CH: 24880 to CH: 24940	GC-HRIDC-C4-DRW-TTL-CLT-01004_A0
5.	Conceptual drawing for Support class VI (i) from CH: 26000 to CH: 28420	GC-HRIDC-C4-DRW-TTL-CLT-01005_A0
6.	Conceptual drawing for Support class VI(ii) from CH: 28420 to CH: 28480	GC-HRIDC-C4-DRW-TTL-CLT-01006_A0
7.	Conceptual drawing for Tunnel typical detail of lattice girder	GC-HRIDC-C4-DRW-TTL-CLT-01007_A0
8.	Conceptual drawing for Cut & cover section of tunnel	GC-HRIDC-C4-DRW-TTL-CLT-01008_A1

S. No	TITLE	DRAWING NO.
9.	Conceptual drawing for Cross passage junction with main tunnel	GC-HRIDC-C4-DRW-TTL-CLT-01009_A1
10.	Conceptual drawing for Permanent Ventilation shaft junction with main tunnel	GC-HRIDC-C4-DRW-TTL-CLT-01010_A2 (Sheet 1 of 3)
		GC-HRIDC-C4-DRW-TTL-CLT-01010_A2 (Sheet 2 of 3)
		GC-HRIDC-C4-DRW-TTL-CLT-01010_A2 (Sheet 3 of 3)
11.	Conceptual drawing for Construction cum utility shaft	GC-HRIDC-C4-DRW-TTL-CLT-01011_A2
12.	Conceptual drawing for Portal-1 & Abutment A2 of viaduct with drainage excavation plan & sections	GC-HRIDC-C4-DRW-TTL-CLT-01012_A1
13.	Conceptual drawing for Portal-2 & open cutting area with 100m ballastless track	GC-HRIDC-C4-DRW-TTL-CLT-01013_A1
3 BRIDGES		
3.1 MINOR BRIDGES		
1.	Conceptual general arrangement drawing for Balancing culvert Bridge no. 047 Span 1.0x2.0x2.0 RCC box at Ch: 12208.018	GC-HRIDC-C4-DRW-BRD-GAD-01047_A1
2.	Conceptual general arrangement drawing for Drain + Road Bridge no. 048 span 1x4.0x5.0+1x5x5 RCC box at Ch: 12298.962	GC-HRIDC-C4-DRW-BRD-GAD-01048_A1
3.	Conceptual general arrangement drawing for pipe culvert Bridge no. 049 span 1.0x1.80ø Pipe culvert at Ch: 12341.836	GC-HRIDC-C4-DRW-BRD-GAD-01049_A1
4.	Conceptual general arrangement drawing for Balancing culvert Bridge no. 050 Span 1.0x2.0x2.0 RCC box at Ch: 12645.715	GC-HRIDC-C4-DRW-BRD-GAD-01050_A1
5.	Conceptual general arrangement drawing canal Bridge no. 051 span 1.0x3.0x3.0 RCC box at Ch: 13114.998	GC-HRIDC-C4-DRW-BRD-GAD-01051_A1
6.	Conceptual general arrangement drawing for Balancing culvert Bridge no. 052 Span 1.0x3.0x3.0 RCC box at Ch: 13903.112	GC-HRIDC-C4-DRW-BRD-GAD-01052_A1

S. No	TITLE	DRAWING NO.
7.	Conceptual general arrangement drawing for canal Bridge no. 054 1.0x3.0x3.0 RCC box at Ch: 14601.627	GC-HRIDC-C4-DRW-BRD-GAD-01054_A1
8.	Conceptual general arrangement drawing for Road under bridge, Bridge no. 055 Span 1x5.0x5.0 RCC box at Ch: 14756.727	GC-HRIDC-C4-DRW-BRD-GAD-01055_A1
9.	Conceptual general arrangement drawing for Balancing culvert Bridge no. 056 Span 1.0x2.0x2.0 RCC box at Ch: 15100.163	GC-HRIDC-C4-DRW-BRD-GAD-01056_A1
10.	Conceptual general arrangement drawing for Road under bridge, Bridge no. 057 Span 1x5.0x5.0 RCC box at Ch: 15944	GC-HRIDC-C4-DRW-BRD-GAD-01057_A1
11.	Conceptual general arrangement drawing proposed RUB no. 060 Span 2x7.0x5.6 RCC box at Ch: 16827	GC-HRIDC-C4-DRW-BRD-GAD-01060_A2
3.2 MAJOR BRIDGES		
1.	Conceptual general arrangement drawing for stream bridge no.53 2x24.4 CG at Ch: 14472.112m	GC-HRIDC-C4-DRW-BRD-GAD-01053_A2
2.	Conceptual general arrangement drawing for Canal Br.no. 058 1 x 5 x 5.4m + 1 x 12.2m + 1 x 5 x 5.4m PSC U slab Ch: 16127	GC-HRIDC-C4-DRW-BRD-GAD-01058_A2
3.	Conceptual general arrangement drawing proposed RUB no. 059 2 x 12.2m PSC U slab Ch: 16727	GC-HRIDC-C4-DRW-BRD-GAD-01059_A2
4.	Conceptual general arrangement drawing proposed Canal Br. No. 061 1x5x5.4+1x12.2+1x5x5.4m PSC U slab Ch: 16917	GC-HRIDC-C4-DRW-BRD-GAD-01061_A2
5.	Conceptual general arrangement drawing proposed RUB no. 062 1 x 12.2m PSC U slab Ch: 17500	GC-HRIDC-C4-DRW-BRD-GAD-01062_A2

S. No	TITLE	DRAWING NO.
4 MISCELLANEOUS DRAWINGS (CONCEPTUAL PLANS)		
1.	Jurisdictional sketch of C-4 package	GC-HRIDC-C4-SK-CIVIL-001_A1
2.	Schematic diagram of HORC tunnel	GC-HRIDC-C4-SK-TUNNEL-001_A1
3.	Conceptual Plan Typical embankment/cutting profile	GC-HRIDC-SK-GEN-001_A2
4.	Conceptual Plan Drains for Embankment	GC-HRIDC-SK-GEN-008_A2
5.	Conceptual Plan Steel barricade	GC-HRIDC-SK-GEN-009
6.	Conceptual Plan Interfacing location bank benching	GC-HRIDC-C4-SK-012_A2
7.	Conceptual Plan CC Toe wall	GC-HRIDC-SK-GEN-014_A2
8.	Conceptual Plan Typical details of protection work	GC-HRIDC-SK-GEN-015_A1
9.	Conceptual Plan Barbed wire fencing	GC-HRIDC-SK-GEN-016_A1
10.	Conceptual Plan for Transition system of bridge approaches	GC-HRIDC-SK-GEN-019_A1
11.	Conceptual plan for Trolley Refuge in embankment	GC-HRIDC-SK-GEN-022
12.	Conceptual plan for Trolley Refuge in cutting	GC-HRIDC-SK-GEN-023
13.	Conceptual sketch for NP4 pipe of 450mm Dia	GC-HRIDC-SK-GEN-028_A1
14.	Conceptual sketch for precast RCC box 500 x 500 mm size	GC-HRIDC-SK-GEN-029_A1
15.	Conceptual general arrangement drawing crossing of HORC rail line below Vadodara expressway	GC-HRIDC-SK-GEN-030_A0
16.	Typical sketch for approach road of RUBs.	GC-HRIDC-SK-GEN-031_A0
17.	Conceptual sketch for details of stairs from cutting in formation to ground	GC-HRIDC-C4-SK-TUNNEL-002_A0
5 GENERAL ELECTRICAL SERVICES DRAWINGS		
1.	Indicative layout plan of Sub-station 11/0.433KV near utility shaft	GC-HRIDC-C4-DRW-TTL-ELE-001_A2
2.	Indicative layout plan of Sub-station 11/0.433KV	GC-HRIDC-C4-DRW-TTL-ELE-002_A2
3.	Power supply for lighting arrangement (indicative)	GC-HRIDC-C4-DRW-TTL-ELE-003_A2
4.	Power supply arrangement for emergency and maintenance power socket diagram (indicative)	GC-HRIDC-C4-DRW-TTL-ELE-004_A2
5.	Single line diagram of HT system in tunnel (indicative)	GC-HRIDC-C4-DRW-TTL-ELE-005_A1

S. No	TITLE	DRAWING NO.
6	LAND AREA FOR TUNNEL	
1.	Land area near Portal-1	HRIDC-C4-SK-LANDPLAN-001_A1
2.	Land area near permanent Ventilation shaft 1 & 2	HRIDC-C4-SK-LANDPLAN-002_A1
3.	Land area near Construction cum utility shaft	HRIDC-C4-SK-LANDPLAN-003_A1
4.	Land area near permanent Ventilation shaft 3 & 4	HRIDC-C4-SK-LANDPLAN-004_A1
5.	Land details from Ch: 28341m to 29680m	HRIDC-C4-SK-LANDPLAN-005_A1

Tunnel

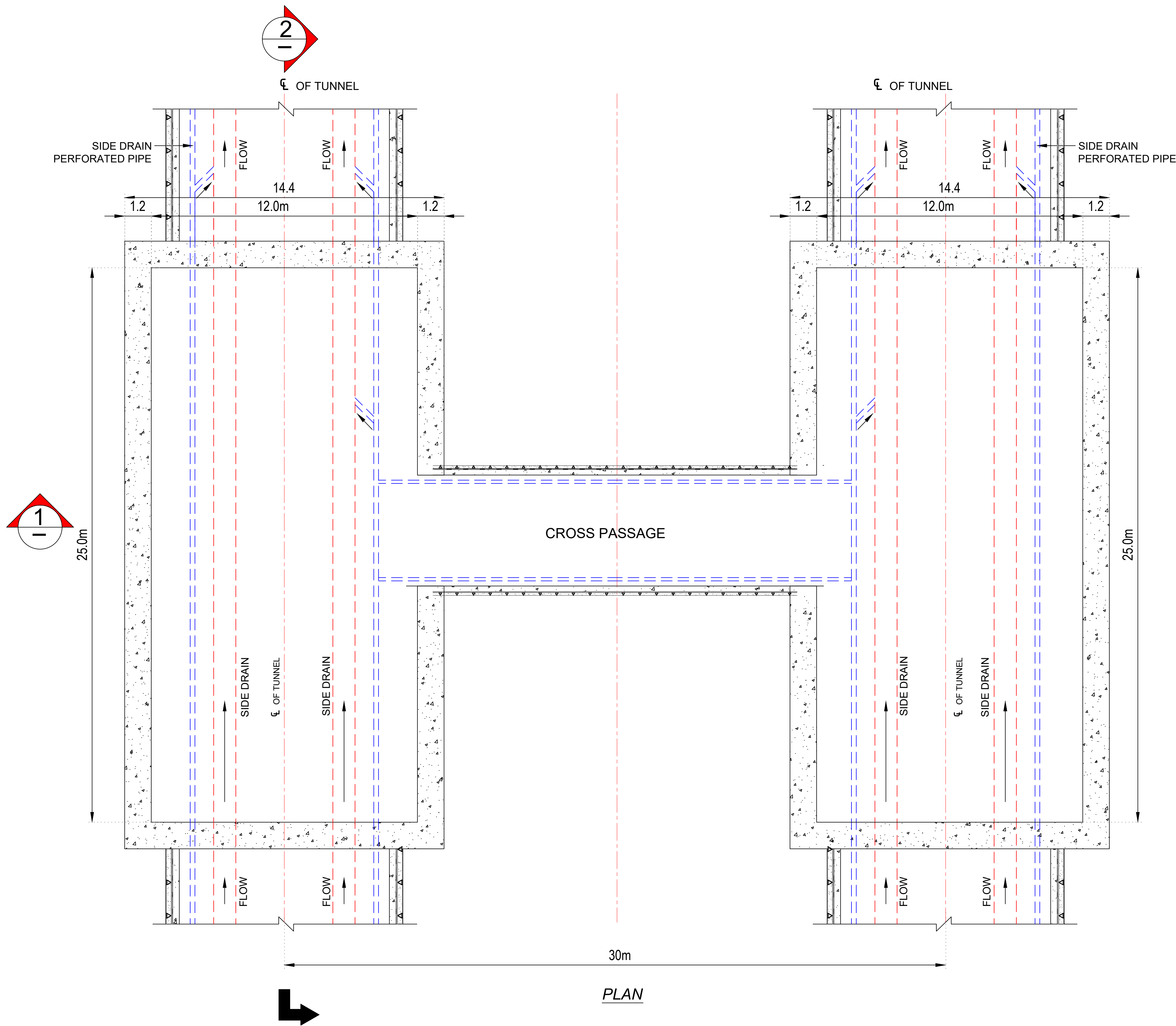

PLAN

- NOTES:-**
1. ALL DIMENSIONS, NORTHING & EASTING AND LEVELS ARE IN METER, UNLESS OTHERWISE SPECIFIED.
 2. NO DIMENSIONS SHALL BE MEASURED FROM DRAWING.
 3. TUNNEL EXCAVATED BY HEADING, BENCHING / MULTI DRIFT METHOD (NATM).
 4. THE GRADE OF SHOTCRETE WITH SFERS AS PER DETAIL DESIGN.
 5. PROPOSED SUPPORT SYSTEM IS BASED ON GIR PROVIDED BY GEOLOGIST. ACTUAL SUPPORT SYSTEM MAY BE REVISED BASED ON ACTUAL RESPONSE OF STRATA DURING EXCAVATION.
 6. DRAINAGE PIPE SHALL BE 150mmØ, PERFORATED PVC PIPE WRAPPED WITH NON-WOVEN GEOTEXTILE FABRIC AS PER IS-4989
 7. EXCAVATION SEQUENCE WILL BE PROVIDED BASED ON GFC.
 8. PIPE ROOFING/FOREPULING OF 114 MM DIA SHALL BE PROVIDED WHERE EVER IT IS REQUIRED.
 9. SELF DRILLING ANCHOR OF CAPACITY 190 KN SHALL BE PROVIDED FOR PRIMARY SUPPORT DURING EXCAVATION.
 10. LATTICE GIRDER 25-25-32 OF DEPTH 187 MM/ ISMB 200 MM SHALL BE INCASSED IN SFERS OF MINIMUM THICKNESS 250 MM.
 11. DIMENSION OF PRIMARY SUPPORT & CONCRETE ARE TENTATIVE.
 12. INSERT PLATES SHALL BE PROVIDED IN THE WALL FOR PROVISION OF SS STAIRS OF MINIMUM WIDTH OF 1.5M.
 13. ROOFING SYSTEM OVER SHAFTS SHALL BE PROVIDED AS PER DBR.

LOCATION	
SHAFT-1	CH:26080
SHAFT-2	
SHAFT-3	CH:27680
SHAFT-4	

PROJECT:- HARYANA ORBITAL RAIL CORRIDOR
 CONNECTING PALWAL TO SONIPAT BYPASSING DELHI AREA BY LINKING ASAOOTI-PATLI-SULTANPUR-ASAUDAH BY NEW ELECTRIFIED BG DOUBLE LINE

CLIENT:- HARYANA RAIL INFRASTRUCTURE DEVELOPMENT CORPORATION LIMITED.

GENERAL CONSULTANT:- GENERAL CONSULTANT FOR HARYANA ORBITAL RAIL CORRIDOR
 RITES Limited in consortium with SMEC International Pty. Ltd.



GCHORC DRG. NO:- GC-HRIDC-C4-DRW-TTL-CLT-01010_A2 SHEET: 1 OF 3

DRAWING NAME: CONCEPTUAL DRAWING FOR PERMANENT VENTILATION SHAFT JUNCTION WITH MAIN TUNNEL

ISSUE DATE: 07.11.2022 REVISED DATE: 09.01.2023

SCALE: AS SHOWN

SMC DRG. NO:- S.M. CONSULTANTS AN ISO 9001 Company

CONSULTANT: SIVENDRA KUMAR TUNNEL DESIGNER, B. R. SHARMA SFC CONSULTANT / TUNNEL, A. A. SAMANT PROJECT INCHARGE

GC/HORC		HRIDC	
NAME / DESIGNATION	SIGN	NAME / DESIGNATION	SIGN
CHAHATEY RAM PD	<i>Chahatey Ram</i>	SHIV OM DWIVEDI CPM/HRIDC	<i>Shiv</i>
SUDHIR AGRAWAL DPD/CIVIL	<i>MS</i>	RAJU SOLANKI DGM/CIVIL/S	<i>Raju</i>
		AM/S&T	
REETU PATIAL CDE / CIVIL	<i>Reetu</i>		
AMARNATH SINGH CRE/S&T	<i>Amarnath Singh</i>	AM/Civil/Plg.	<i>Amarnath</i>
STIPHEN SAHOO SRE/Elect.	<i>Stephen</i>	JGM/L&U	<i>Stephen</i>

RELEASED FOR: PRELIMINARY FOR APPROVAL TENDER CONSTRUCTION

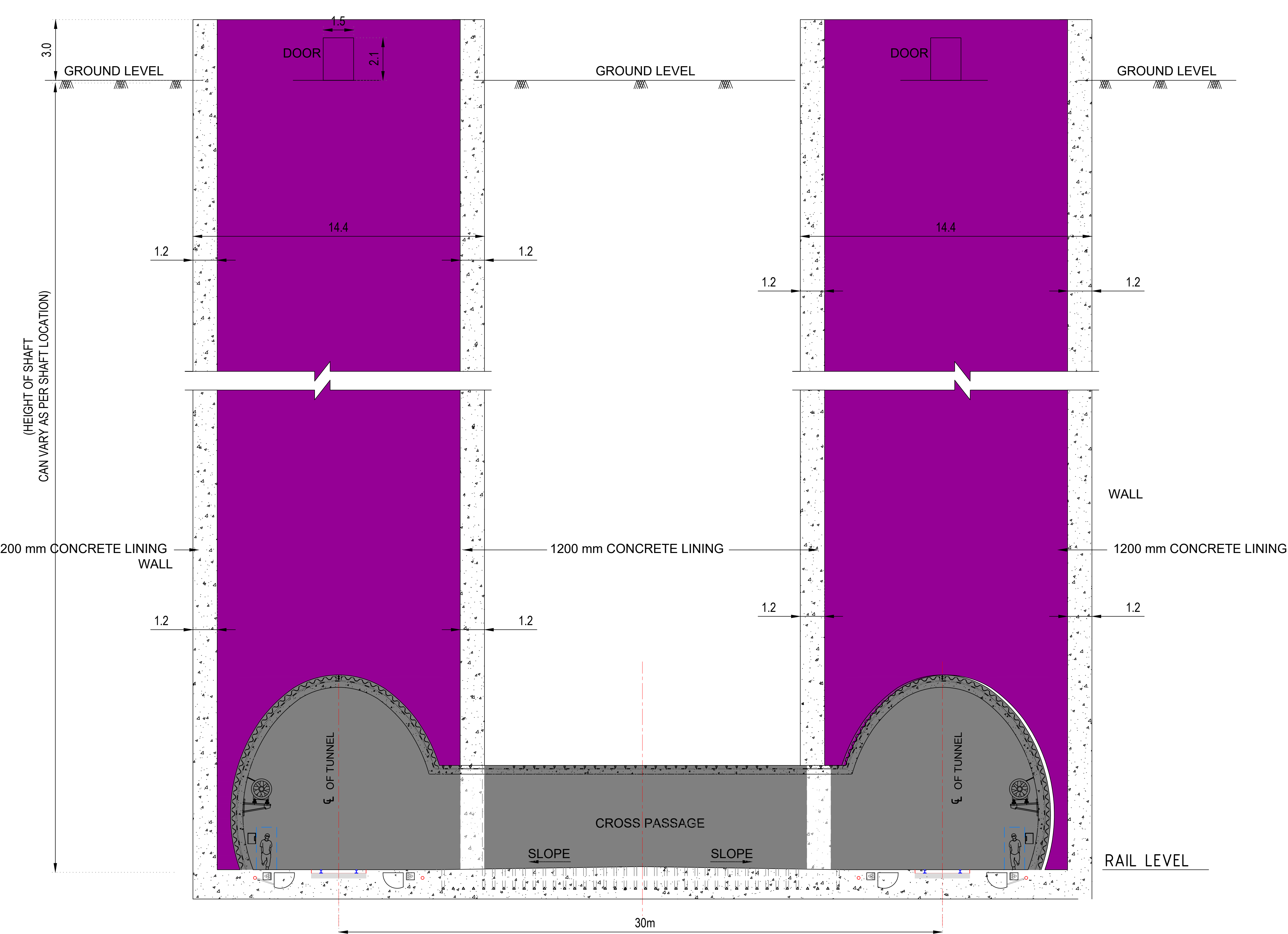

SECTIONAL ELEVATION 1-1

- NOTES:-**
1. ALL DIMENSIONS, NORTHING & EASTING AND LEVELS ARE IN METER, UNLESS OTHERWISE SPECIFIED.
 2. NO DIMENSIONS SHALL BE MEASURED FROM DRAWING.
 3. TUNNEL EXCAVATED BY HEADING, BENCHING / MULTI DRIFT METHOD (NATM).
 4. THE GRADE OF SHOTCRETE WITH SFRS AS PER DETAIL DESIGN. PROPOSED SUPPORT SYSTEM IS BASED ON GIR PROVIDED BY GEOLOGIST. ACTUAL SUPPORT SYSTEM MAY BE REVISED BASED ON ACTUAL RESPONSE OF STRATA DURING EXCAVATION.
 5. DRAINAGE PIPE SHALL BE 150mmØ, PERFORATED PVC PIPE WRAPPED WITH NON-WOVEN GEOTEXTILE FABRIC AS PER IS-4989
 6. EXCAVATION SEQUENCE WILL BE PROVIDED BASED ON GFC.
 7. PIPE ROOFING/FOREPULPING OF 114 MM DIA SHALL BE PROVIDED WHERE EVER IT IS REQUIRED.
 8. SELF DRILLING ANCHOR OF CAPACITY 190 KN SHALL BE PROVIDED FOR PRIMARY SUPPORT DURING EXCAVATION.
 9. LATTICE GIRDER 25-25-32 OF DEPTH 187 MM/ ISMB 200 MM SHALL BE INCASERD IN SFRS OF MINIMUM THICKNESS 250 MM.
 10. DIMENSION OF PRIMARY SUPPORT & CONCRETE ARE TENTATIVE.
 11. INSERT PLATES SHALL BE PROVIDED IN THE WALL FOR PROVISION OF SS STAIRS OF MINIMUM WIDTH OF 1.5M.

LOCATION	
SHAFT-1	CH:26080
SHAFT-2	
SHAFT-3	CH:27680
SHAFT-4	

PROJECT:- HARYANA ORBITAL RAIL CORRIDOR
 CONNECTING PALWAL TO SONIPAT BYPASSING DELHI AREA BY LINKING ASAOOTI-PATLI-SULTANPUR-ASAUDAH BY NEW ELECTRIFIED BG DOUBLE LINE

CLIENT:- HARYANA RAIL INFRASTRUCTURE DEVELOPMENT CORPORATION LIMITED.

GENERAL CONSULTANT:
 GENERAL CONSULTANT FOR HARYANA ORBITAL RAIL CORRIDOR
 RITES Limited in consortium with SMEC International Pty. Ltd.



GC/HORC		HRDC	
NAME / DESIGNATION	SIGN	NAME / DESIGNATION	SIGN
CHAHATEY RAM PD	<i>Chahatey Ram</i>	SHIV OM DWIVEDI CPM/HRDC	<i>Shiv</i>
SUDHIR AGRAWAL DPD/CIVIL	<i>MS</i>	RAJU SOLANKI DGM/CIVIL/S	<i>Raju</i>
		AM/S&T	
REETU PATIAL CDE /CIVIL	<i>Reetu</i>		
AMARNATH SINGH CRE/S&T	<i>Amarnath Singh</i>	AM/Civil/Pig.	<i>Amarnath</i>
STIPHEN SAHOO SRE/Elect.	<i>Stephen</i>	JGM/L&U	<i>Stephen</i>

GCHORC DRG. NO:- GC-HRIDC-C4-DRW-TTL-CLT-01010_A2 SHEET: 2 OF 3

DRAWING NAME: CONCEPTUAL DRAWING FOR PERMANENT VENTILATION SHAFT JUNCTION WITH MAIN TUNNEL

ISSUE DATE: 07.11.2022 REVISED DATE: 09.01.2023

SCALE: AS SHOWN

SMC DRG. NO:- SMC/HRDC/TUNCS-7

CONSULTANT: S.M. CONSULTANTS

PRELIMINARY FOR APPROVAL TENDER CONSTRUCTION

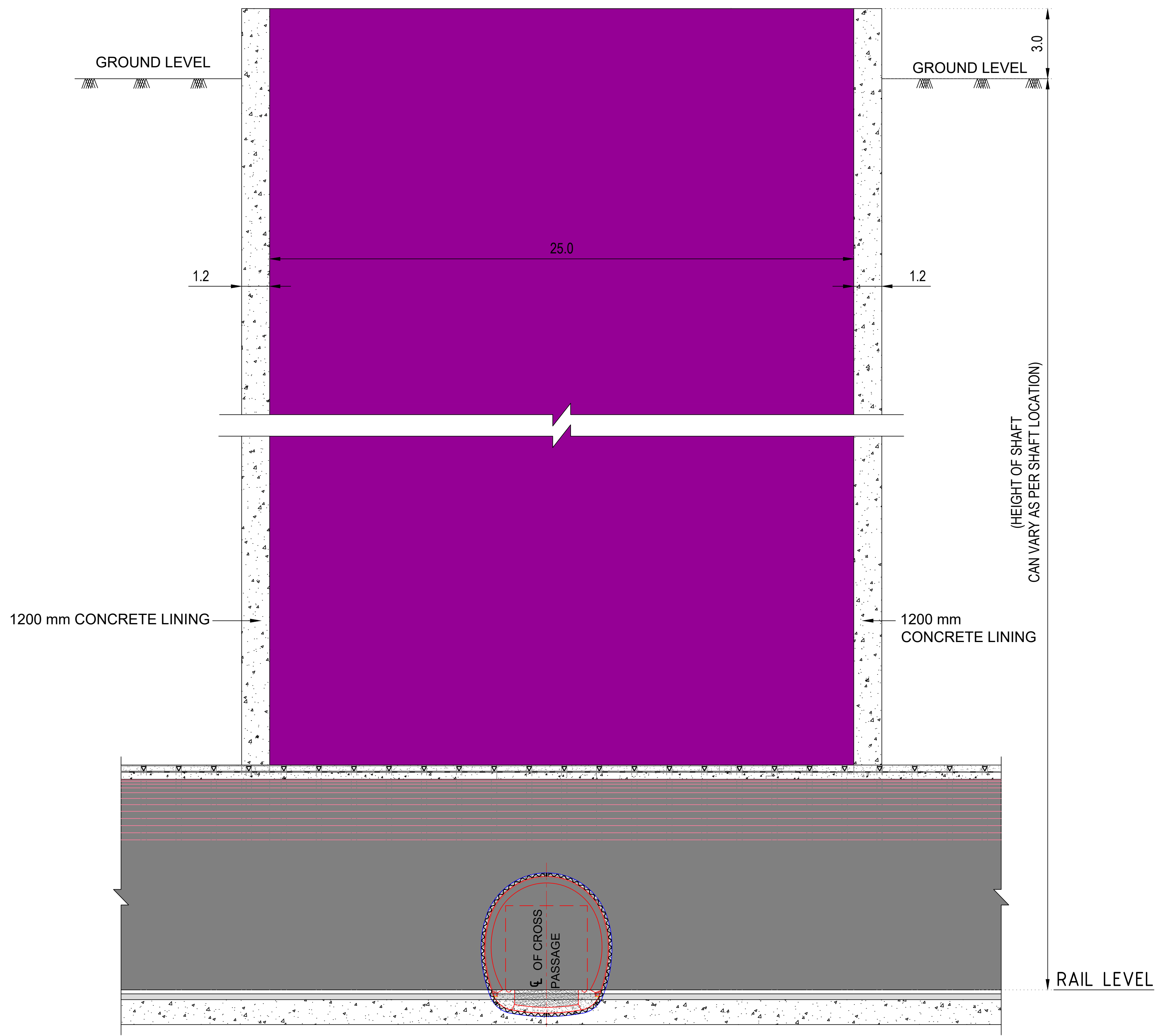

SECTIONAL ELEVATION 2-2

- NOTES:-**
1. ALL DIMENSIONS, NORTHING & EASTING AND LEVELS ARE IN METER, UNLESS OTHERWISE SPECIFIED.
 2. NO DIMENSIONS SHALL BE MEASURED FROM DRAWING.
 3. TUNNEL EXCAVATED BY HEADING, BENCHING / MULTI DRIFT METHOD (NATM).
 4. THE GRADE OF SHOTCRETE WITH SFRS AS PER DETAIL DESIGN.
 5. PROPOSED SUPPORT SYSTEM IS BASED ON GIR PROVIDED BY GEOLOGIST. ACTUAL SUPPORT SYSTEM MAY BE REVISED BASED ON ACTUAL RESPONSE OF STRATA DURING EXCAVATION.
 6. DRAINAGE PIPE SHALL BE 150mmØ, PERFORATED PVC PIPE WRAPPED WITH NON-WOVEN GEOTEXTILE FABRIC AS PER IS-4989
 7. EXCAVATION SEQUENCE WILL BE PROVIDED BASED ON GFC.
 8. PIPE ROOFING/FOREPULING OF 114 MM DIA SHALL BE PROVIDED WHERE EVER IT IS REQUIRED.
 9. SELF DRILLING ANCHOR OF CAPACITY 190 KN SHALL BE PROVIDED FOR PRIMARY SUPPORT DURING EXCAVATION.
 10. LATTICE GIRDER 25-25-32 OF DEPTH 187 MM/ ISMB 200 MM SHALL BE INCASED IN SFRS OF MINIMUM THICKNESS 250 MM.
 11. DIMENSION OF PRIMARY SUPPORT & CONCRETE ARE TENTATIVE.
 12. INSERT PLATES SHALL BE PROVIDED IN THE WALL FOR PROVISION OF SS STAIRS OF MINIMUM WIDTH OF 1.5M.

LOCATION	
SHAFT-1	CH:26080
SHAFT-2	
SHAFT-3	CH:27680
SHAFT-4	

PROJECT:- HARYANA ORBITAL RAIL CORRIDOR
 CONNECTING PALWAL TO SONIPAT BYPASSING DELHI AREA BY LINKING ASAOTI-PATLI-SULTANPUR-ASAUDAH BY NEW ELECTRIFIED BG DOUBLE LINE

CLIENT:- HARYANA RAIL INFRASTRUCTURE DEVELOPMENT CORPORATION LIMITED.

GENERAL CONSULTANT:
 GENERAL CONSULTANT FOR HARYANA ORBITAL RAIL CORRIDOR
 RITES Limited in consortium with SMEC International Pty. Ltd.



GC/HORC		HRDC	
NAME / DESIGNATION	SIGN	NAME / DESIGNATION	SIGN
CHAHATEY RAM PD	<i>Chahatey Ram</i>	SHIV OM DWIVEDI CPM/HRDC	<i>Shiv</i>
SUDHIR AGRAWAL DPD/CIVIL	<i>Sudhir</i>	RAJU SOLANKI DGM/CIVIL/S	<i>Raju</i>
		AM/S&T	
REETU PATIAL CDE /CIVIL	<i>Reetu</i>		
AMARNATH SINGH CRE/S&T	<i>Amarnath Singh</i>	AM/Civil/Plg.	<i>Amarnath</i>
STIPHEN SAHOO SRE/Elect.	<i>Stephen</i>	JGM/L&U	<i>Stephen</i>

GOHORC DRG. NO:- GC-HRIDC-C4-DRW-TTL-CLT-01010_A2 SHEET: 3 OF 3

DRAWING NAME: CONCEPTUAL DRAWING FOR PERMANENT VENTILATION SHAFT JUNCTION WITH MAIN TUNNEL

ISSUE DATE: 07.11.2022 REVISED DATE: 09.01.2023

SCALE: AS SHOWN

SMC DRG. NO:- S.M. CONSULTANTS

CONSULTANT: S.M. CONSULTANTS

RELEASED FOR: PRELIMINARY FOR APPROVAL TENDER CONSTRUCTION

SIVENDRA KUMAR TUNNEL DESIGNER

B. R. SHARMA S.M. CONSULTANT / TUNNEL

A. A. SAMANT PROJECT INCHARGE

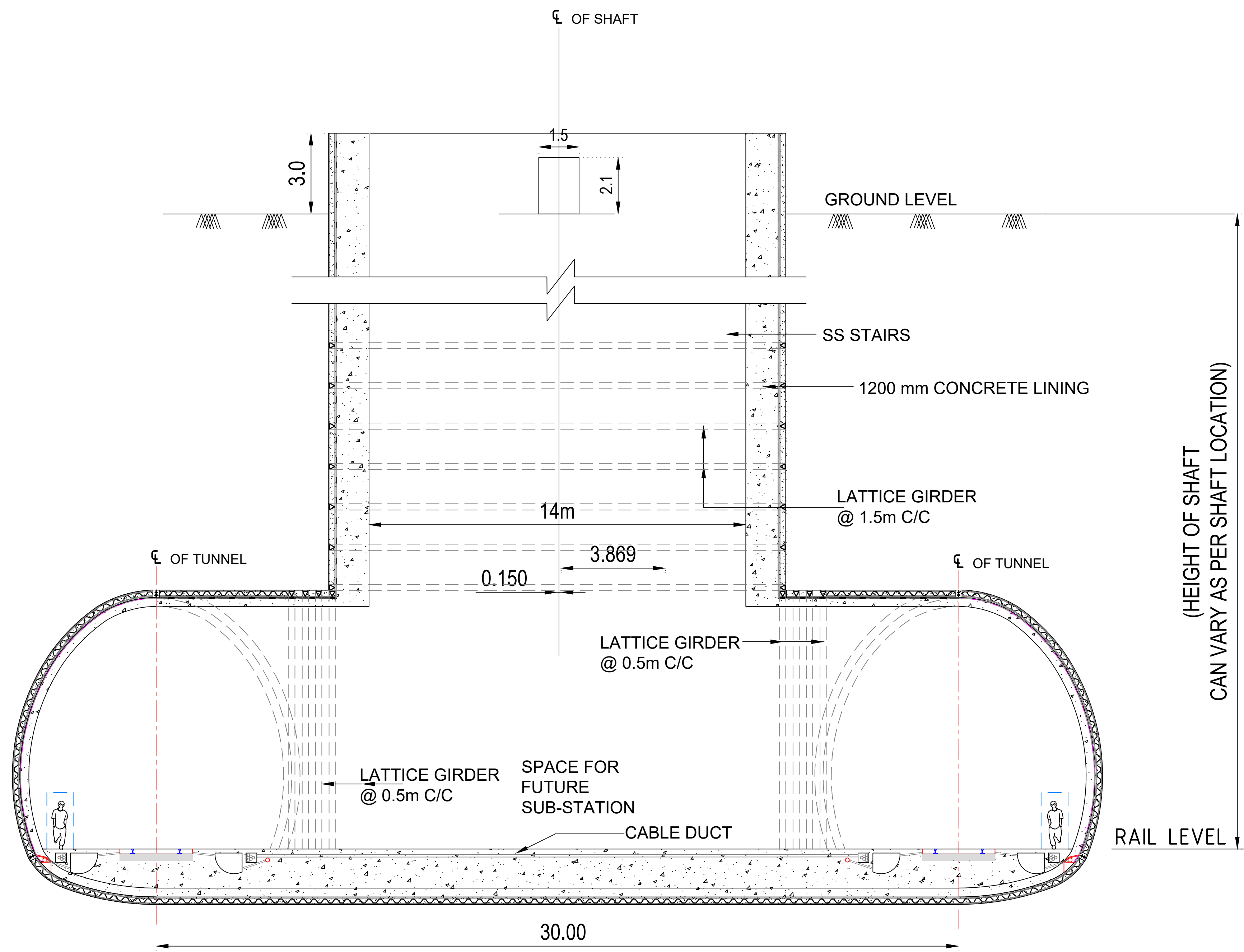

HEIGHT OF SHAFT
CAN VARY AS PER SHAFT LOCATION

SECTIONAL ELEVATION

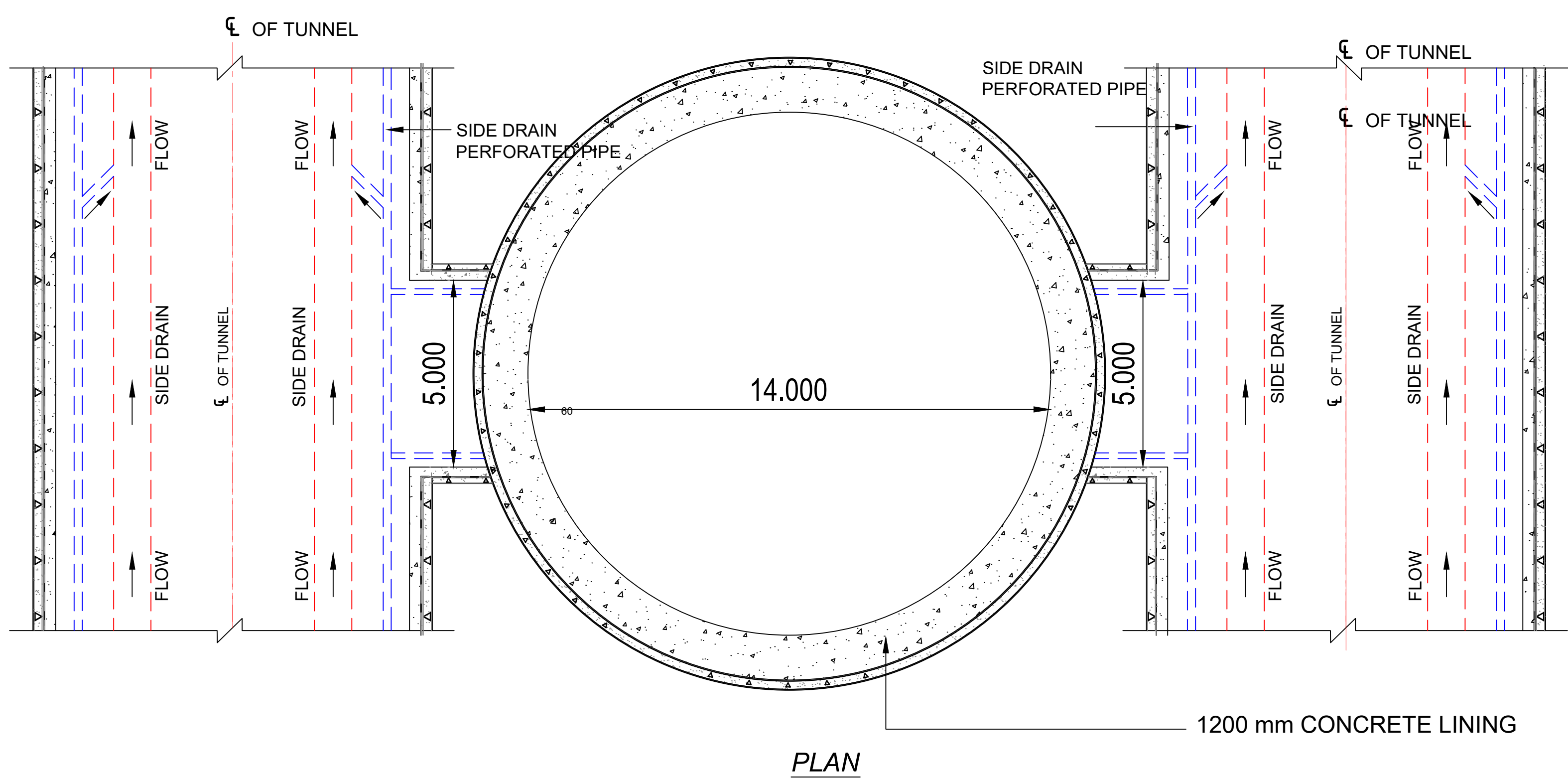

PLAN

- NOTES:-**
1. ALL DIMENSIONS, NORTHING & EASTING AND LEVELS ARE IN METER, UNLESS OTHERWISE SPECIFIED.
 2. NO DIMENSIONS SHALL BE MEASURED FROM DRAWING.
 3. TUNNEL EXCAVATED BY HEADING, BENCHING / MULTI DRIFT METHOD (NATM).
 4. THE GRADE OF SHOTCRETE WITH SFRS AS PER DETAIL DESIGN. PROPOSED SUPPORT SYSTEM IS BASED ON GIR PROVIDED BY GEOLOGIST. ACTUAL SUPPORT SYSTEM MAY BE REVISED BASED ON ACTUAL RESPONSE OF STRATA DURING EXCAVATION.
 5. DRAINAGE PIPE SHALL BE 150mmØ, PERFORATED PVC PIPE WRAPPED WITH NON-WOVEN GEOTEXTILE FABRIC AS PER IS-4989 EXCAVATION SEQUENCE WILL BE PROVIDED BASED ON GFC.
 6. PIPE ROOFING/FOREPULPING OF 114 MM DIA SHALL BE PROVIDED WHERE EVER IT IS REQUIRED.
 7. SELF DRILLING ANCHOR OF CAPACITY 190 KN SHALL BE PROVIDED FOR PRIMARY SUPPORT DURING EXCAVATION.
 8. LATTICE GIRDER 25-25-32 OF DEPTH 187 MM/ ISMB 200 MM SHALL BE INCASED IN SFRS OF MINIMUM THICKNESS 250 MM.
 9. DIMENSION OF PRIMARY SUPPORT & CONCRETE ARE TENTATIVE.
 10. INSERT PLATES SHALL BE PROVIDED IN THE WALL FOR PROVISION OF SS STAIRS OF MINIMUM WIDTH OF 1.5M.
 11. ROOFING SYSTEM OVER SHAFTS SHALL BE PROVIDED AS PER DBR.

GC/HORC		HRDC	
NAME / DESIGNATION	SIGN	NAME / DESIGNATION	SIGN
CHAHATEY RAM PD	<i>Chahatey Ram</i>	SHIV OM DWIVEDI CPM/HRDC	<i>Shiv</i>
SUDHIR AGRAWAL DPD/CIVIL	<i>MS</i>	RAJU SOLANKI DGM/CIVIL/S	<i>Raju</i>
		AM/S&T	
REETU PATIAL CDE / CIVIL	<i>Reetu</i>		
AMARNATH SINGH CRE/S&T	<i>Amarnath Singh</i>	AM/Civil/Pig	<i>Amarnath</i>
STIPHEN SAHOO SRE/Elect.	<i>Stephen</i>	JGM/L&U	<i>Stephen</i>

PROJECT:- HARYANA ORBITAL RAIL CORRIDOR
CONNECTING PALWAL TO SONIPAT BYPASSING DELHI AREA BY LINKING ASAOPTI-PATLI-SULTANPUR-ASAUDAH BY NEW ELECTRIFIED BG DOUBLE LINE

CLIENT:- HARYANA RAIL INFRASTRUCTURE DEVELOPMENT CORPORATION LIMITED.

GENERAL CONSULTANT:- RITES Limited in consortium with SMEC International Pty. Ltd.

GC/HORC DRG. NO:- GC-HRIDC-C4-DRW-TTL-CLT-01011_A2

DRAWING NAME: CONCEPTUAL DRAWING FOR CONSTRUCTION CUM UTILITY SHAFT

ISSUE DATE: 07.11.2022 | REVISED DATE: 09.01.2023

SCALE: AS SHOWN

SMC DRG. NO:- SMC/HRIDC/TUNCS-7

CONSULTANT: S.M. CONSULTANTS AN ISO 9001 Company

PRELIMINARY FOR APPROVAL: TENDER: CONSTRUCTION:

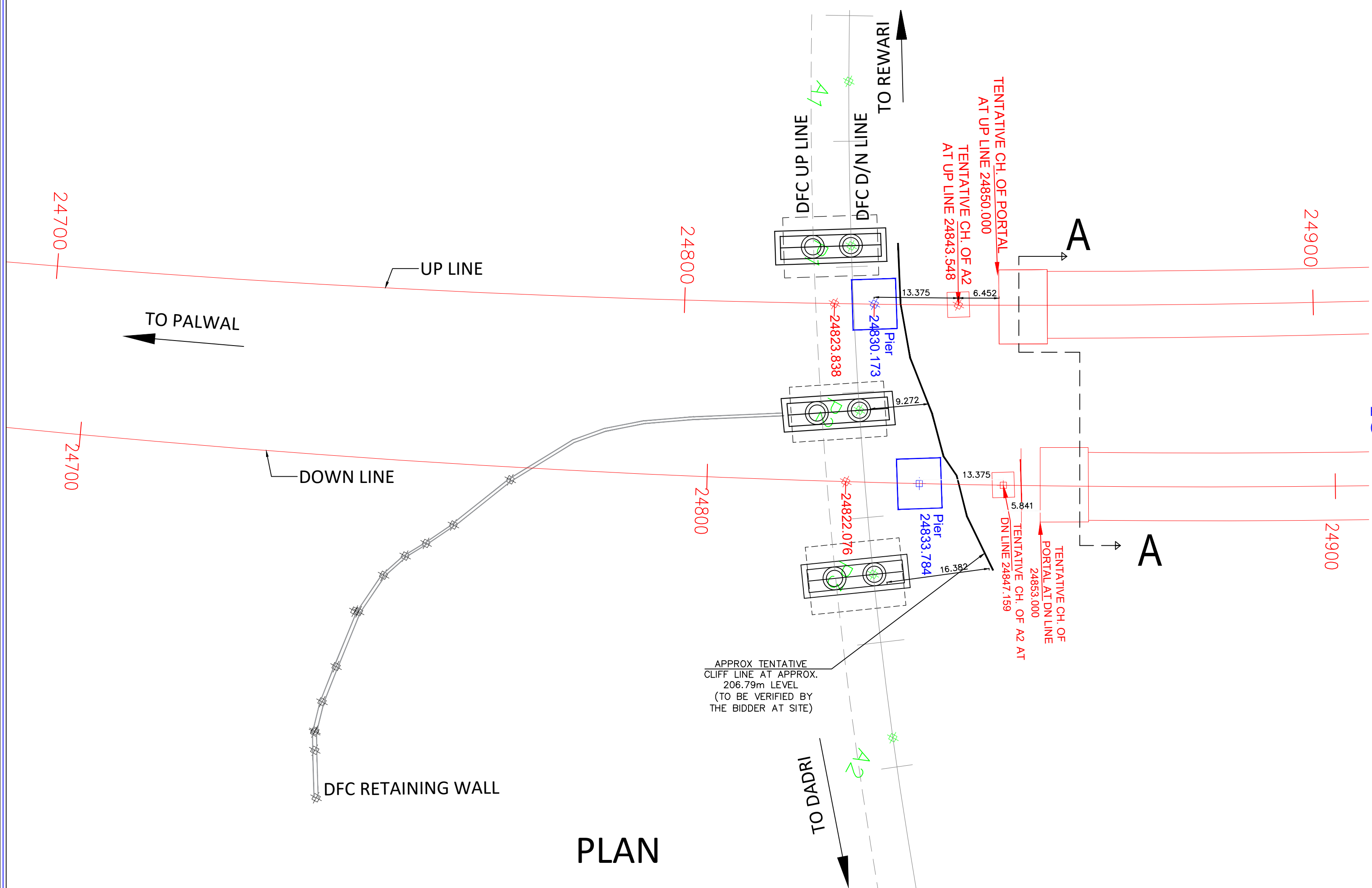

C/L OF DFC BR-87 (VIADUCT)
4x26.1 m PSC GIRDER

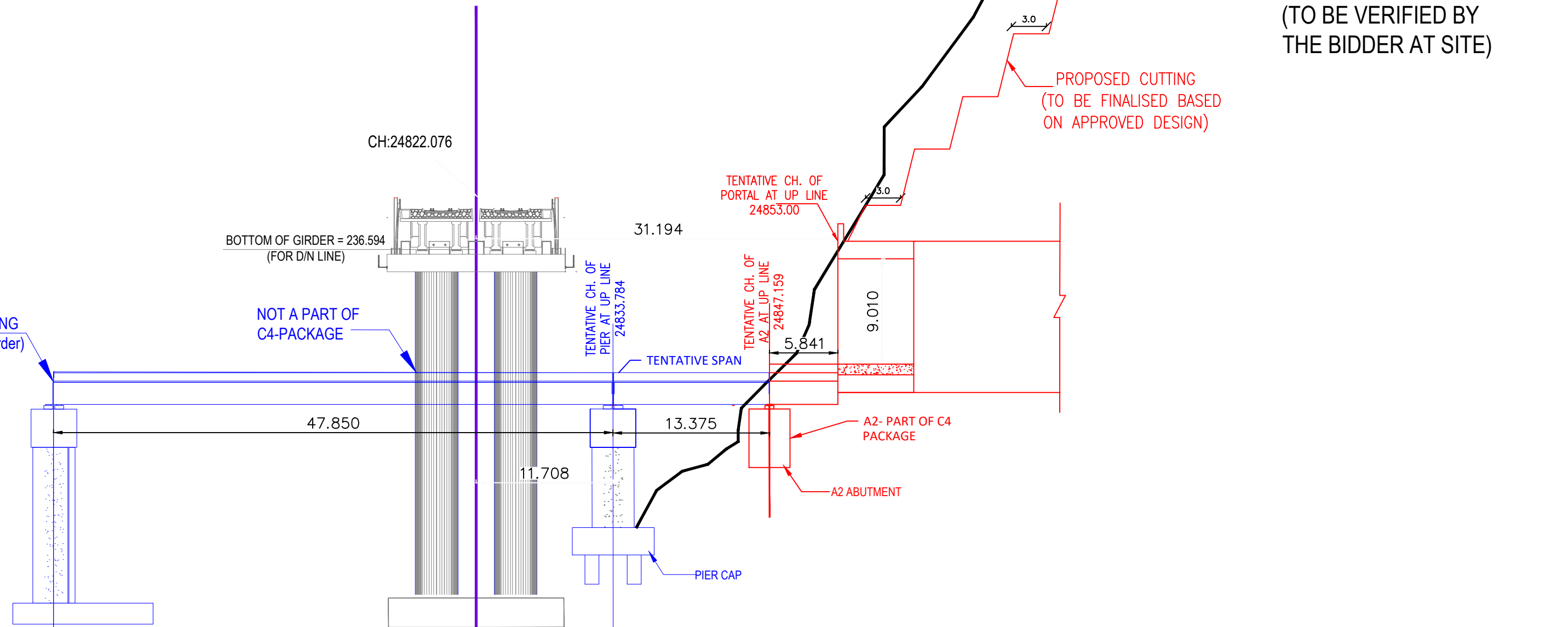

C/L OF DFC BR-87 (VIADUCT)
4x26.1 m PSC GIRDER

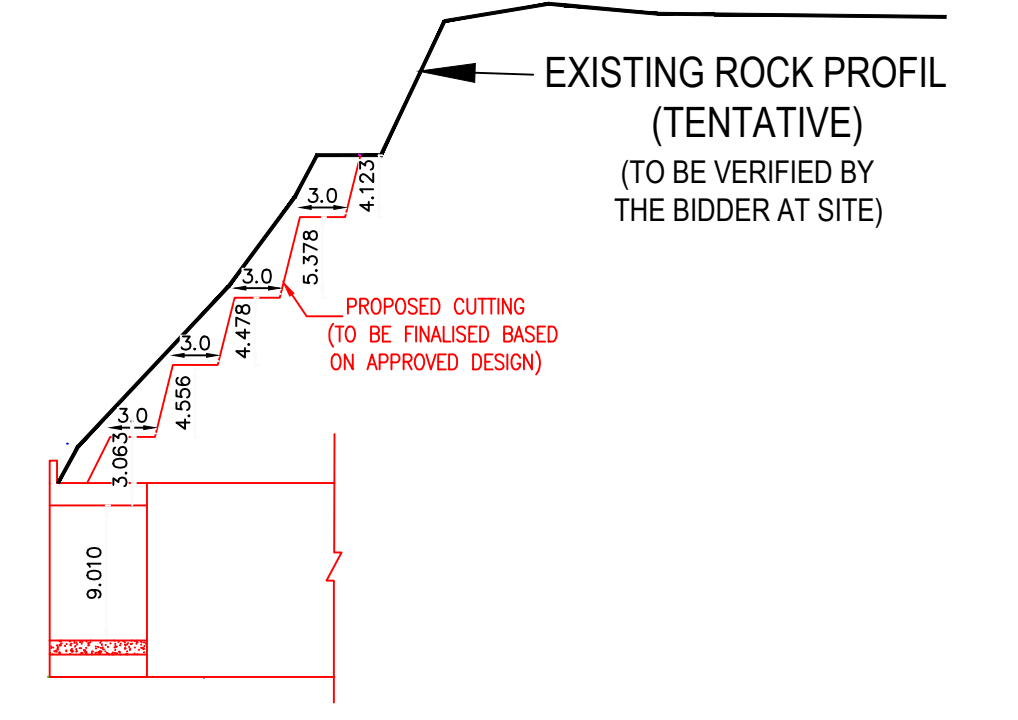
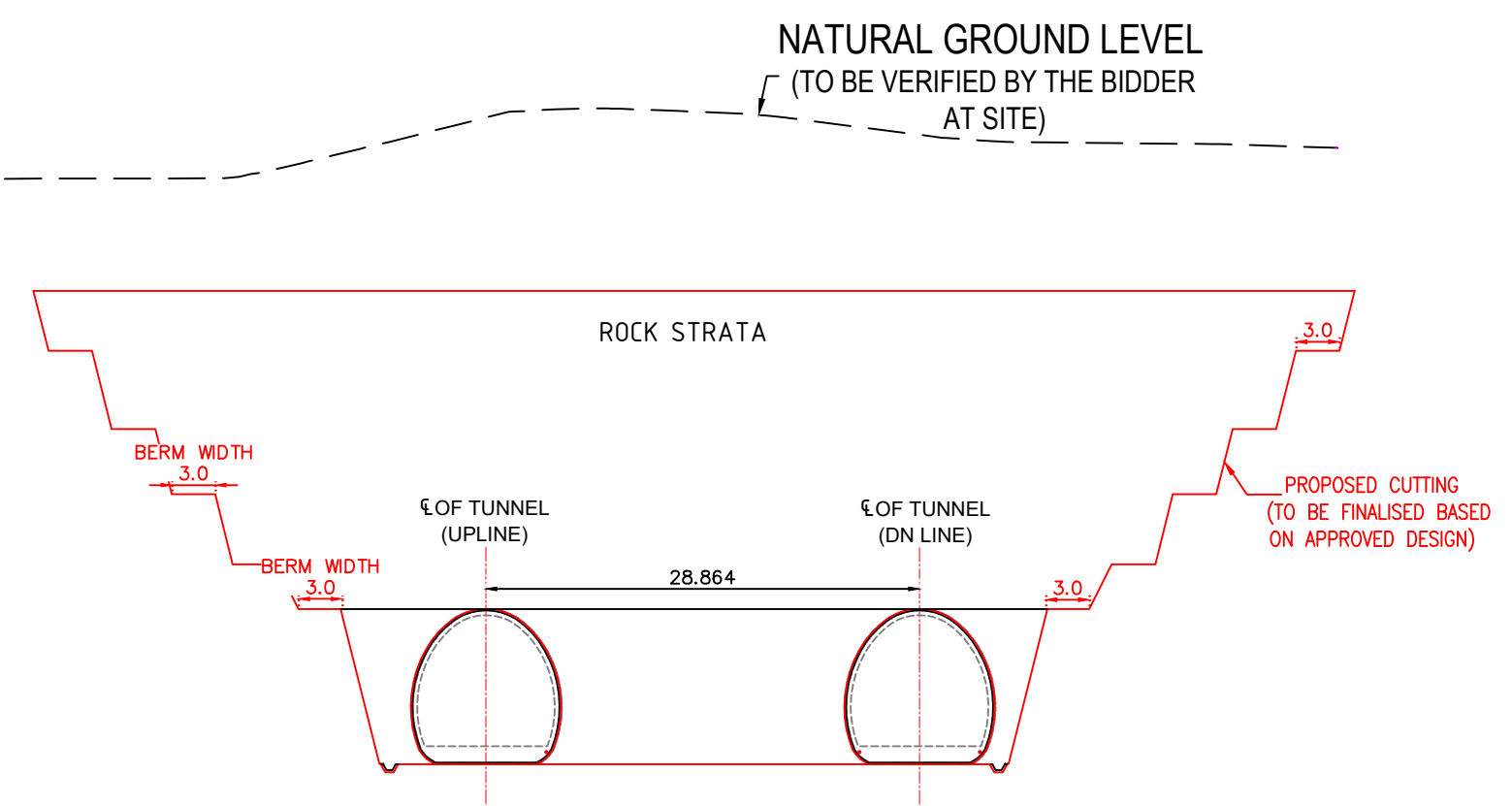
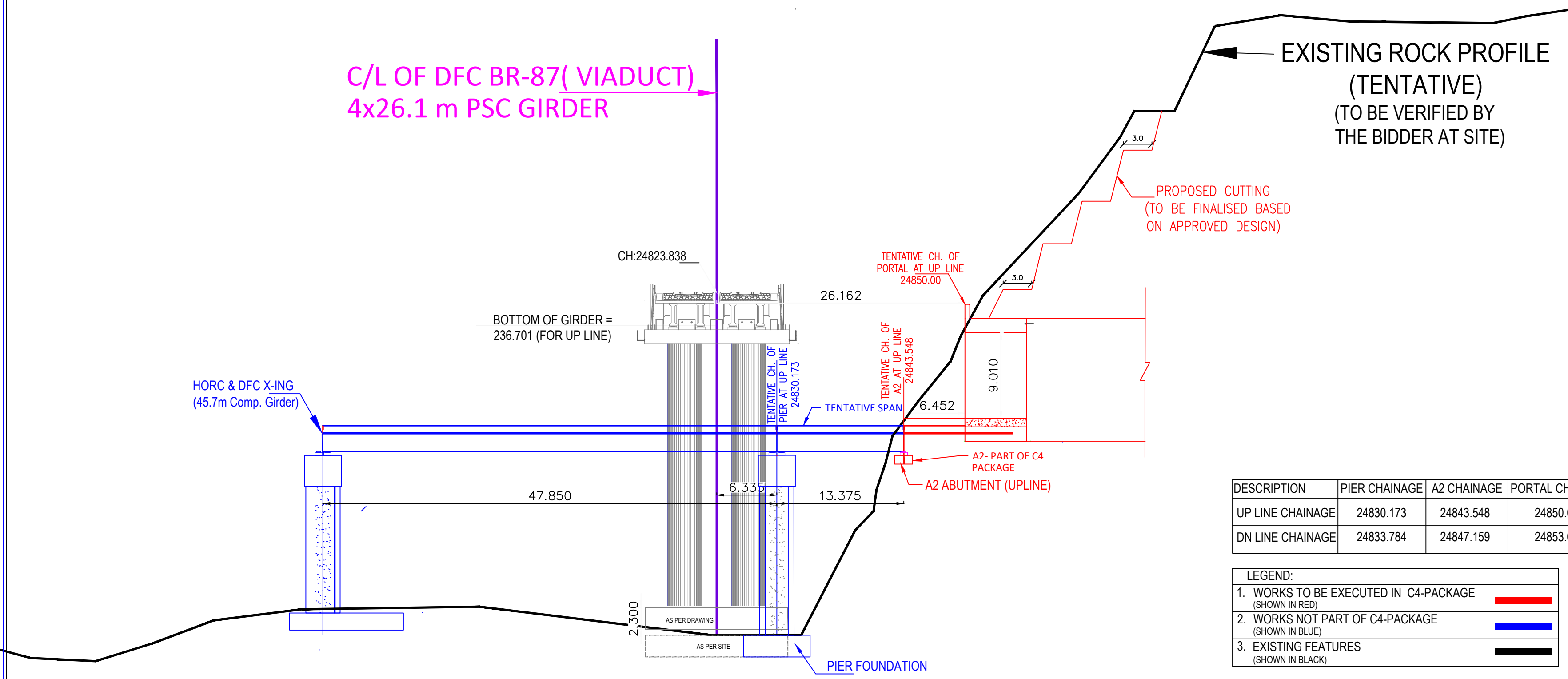

DESCRIPTION	PIER CHAINAGE	A2 CHAINAGE	PORTAL CHAINAGE
UP LINE CHAINAGE	24830.173	24843.548	24850.000
DN LINE CHAINAGE	24833.784	24847.159	24853.000

LEGEND:

1. WORKS TO BE EXECUTED IN C4-PACKAGE (SHOWN IN RED)	—
2. WORKS NOT PART OF C4-PACKAGE (SHOWN IN BLUE)	—
3. EXISTING FEATURES (SHOWN IN BLACK)	—

NOTE:

- THE CHAINAGE OF PORTALS OF UP & DOWN LINE SHOWN ARE TENTATIVE AND WILL BE FINALISED BASED ON THE APPROVED DESIGN OF TUNNEL.
- CHAINAGES SHOWN ARE RECKONED FROM C/L OF PRITHALA STATION BUILDING TAKEN AS 0.00m, WITH RESPECT TO UP MAIN LINE.

GC/HORC		HRIDC	
NAME / DESIGNATION	SIGN	NAME / DESIGNATION	SIGN
CHAHATEY RAM PD	<i>Chahatey Ram</i>	SHIV OM DWIVEDI CPM/HRIDC	<i>Shiv</i>
SUDHIR AGRAWAL DPD/CIVIL	<i>Sh</i>	RAJU SOLANKI DGM/CIVIL/S	<i>Raju</i>
REETU PATIAL CDE/CIVIL	<i>Reetu</i>	AM/S&T	
AMARNATH SINGH CRE/S&T	<i>Amarnath Singh</i>	AM/Civil/Pig.	<i>Amarnath</i>
STEPHEN SAHOO SRE/Elect.	<i>Stephen</i>	JGM/L&U	<i>Stephen</i>

PROJECT: HARYANA ORBITAL RAIL CORRIDOR
CONNECTING PALWAL TO SONPAT BYPASSING DELHI AREA BY LINKING ASAOTI-PATLI-SULTANPUR-ASAUDAH BY NEW ELECTRIFIED BG DOUBLE LINE

CLIENT: HARYANA RAIL INFRASTRUCTURE DEVELOPMENT CORPORATION LIMITED.

GENERAL CONSULTANT: GENERAL CONSULTANT FOR HARYANA ORBITAL RAIL CORRIDOR
RITES Limited in consortium with SMEC International Pty. Ltd.

GOHORC DRG. NO.: GC-HRIDC-C4-DRW-TTL-CLT-01012_A1

DRAWING NAME: CONCEPTUAL DRAWING FOR PORTAL-1 & ABUTMENT A2 OF PROPOSED HORC VIADUCT

ISSUE DATE: 07.11.2022 **REVISED DATE:** 09.01.2023

SCALE: AS SHOWN

SMC DRG. NO.: SMC/HRIDC/TUN/CS- 7

CONSULTANT: S.M. CONSULTANTS
AN ISO 9001 Company

DESIGNER: SIVENDRA KUMAR TUNNEL DESIGNER
CHECKER: B. R. SHARMA
PROJECT INCHARGE: A. A. SAMANT

RELEASED FOR: PRELIMINARY FOR APPROVAL TENDER CONSTRUCTION

DETAILS OF SIDE DRAIN & PORTAL 2

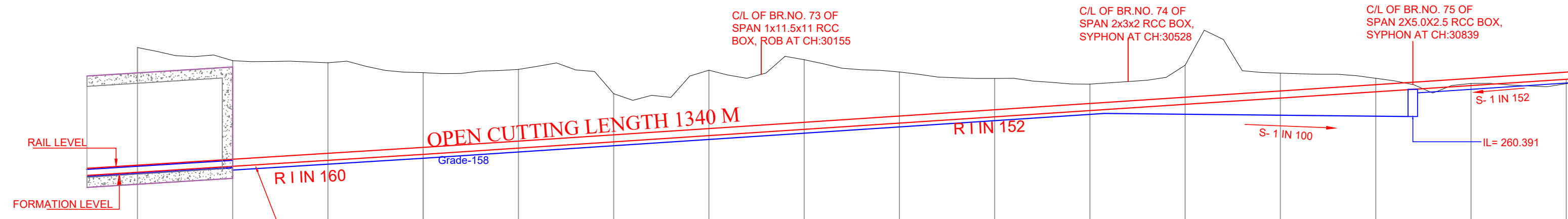
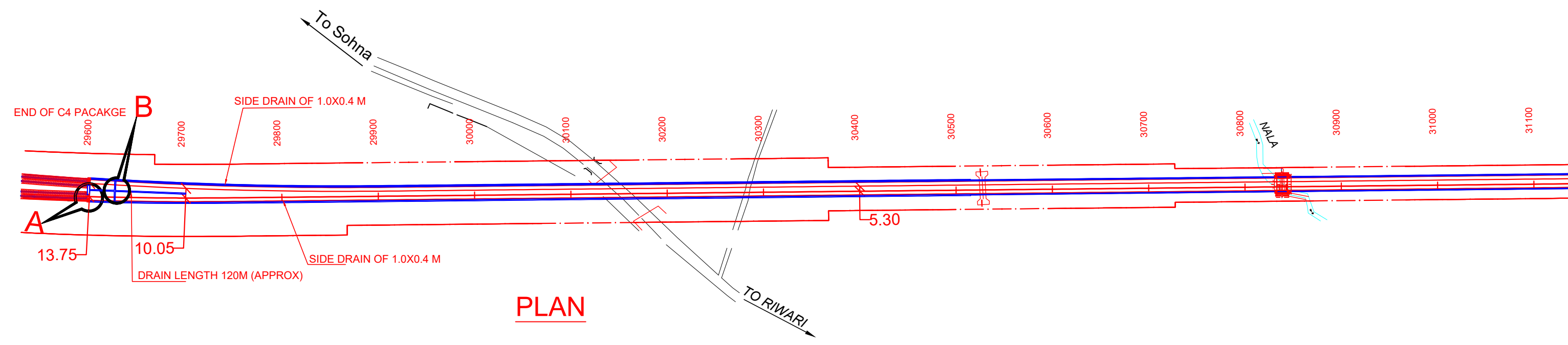

DATUM = 240.00

BANKING (+ ve) CUTTING (- ve)	-13.110	-11.108	-10.254	-8.600	-8.269	-5.060	-6.878	-7.315	-5.376	-4.025	-2.777	-4.112	-2.612	-1.418	-0.218	0.468
PROPOSED FORMATION LEVEL	254.530	255.155	255.780	256.405	257.063	257.721	258.379	259.037	259.695	260.353	261.010	261.668	262.326	262.984	263.642	264.300
GROUND LEVEL	267.640	266.263	266.034	265.005	265.332	262.781	265.257	266.352	265.071	264.378	263.787	265.780	264.938	264.402	263.860	263.832
CHAINAGE	29500	29600	29700	29800	29900	30000	30100	30200	30300	30400	30500	30600	30700	30800	30900	31000

LONGITUDINAL SECTION

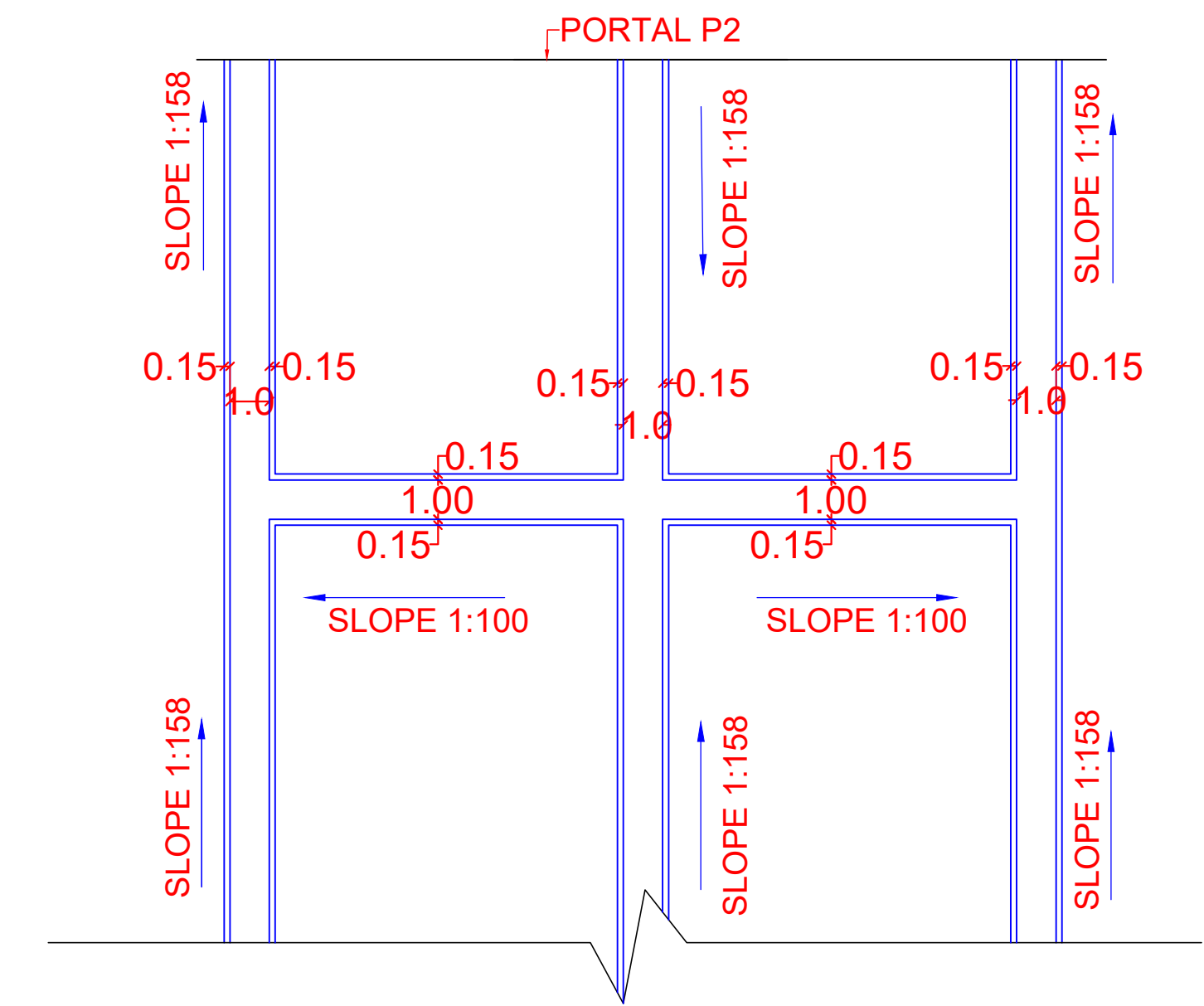

DETAILS OF 'B'

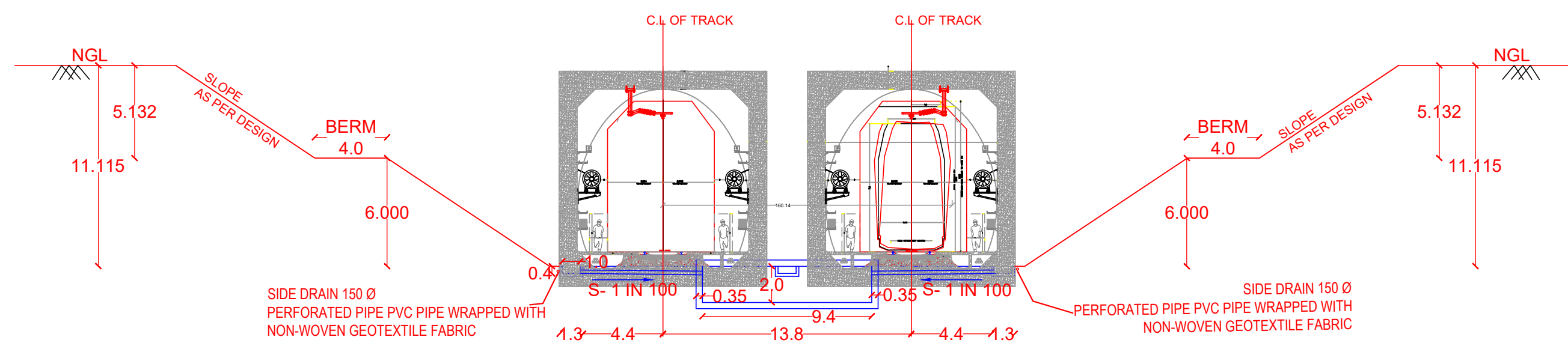

CROSS SECTION AT CUTTING AT PORTAL

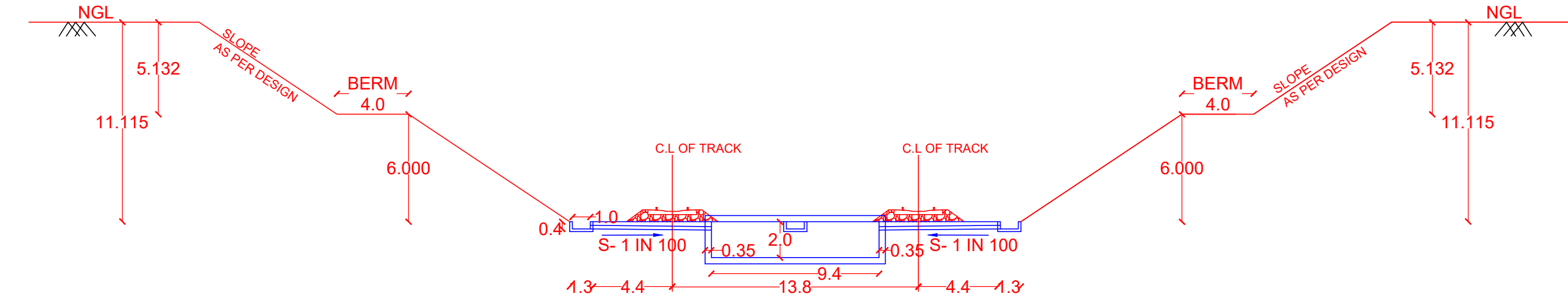

CROSS SECTION AT CUTTING BEFORE PORTAL

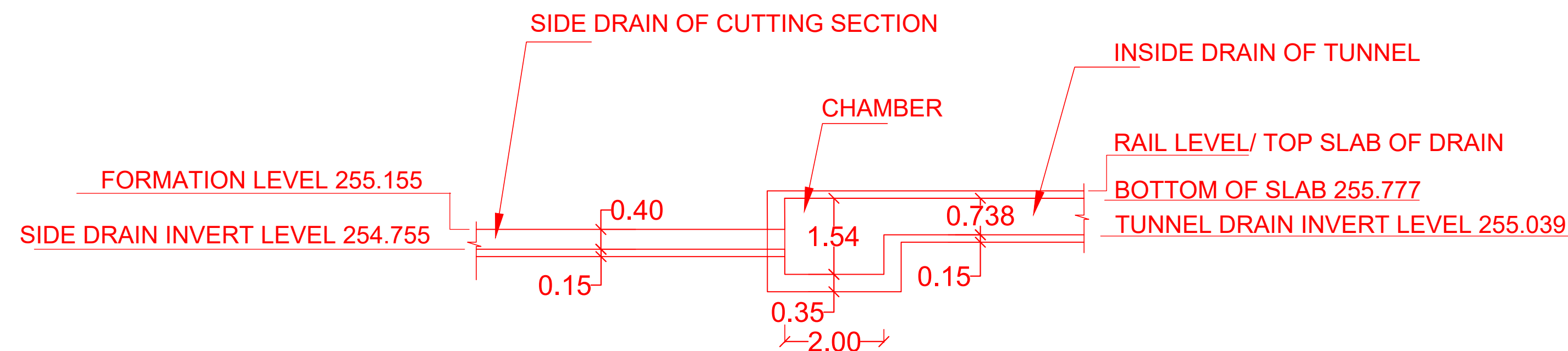

**DETAILS OF 'A'
DRAIN SLOPE AS PER FORMATION**

GC/HORC		HRIDC	
NAME / DESIGNATION	SIGN	NAME / DESIGNATION	SIGN
CHAHATEY RAM PD	<i>Chahatey Ram</i>	SHIV OM DWIVEDI CPM/HRIDC	<i>Shiv</i>
SUDHIR AGRAWAL DPD/CIVIL	<i>Shiv</i>	RAJU SOLANKI DGM/CIVIL/S	<i>Raju</i>
REETU PATIAL CDE/CIVIL	<i>Reetu</i>	AM/S&T	
AMARNATH SINGH CRE/S&T	<i>Amarnath Singh</i>	AM/Civil/Pig	<i>Amarnath</i>
STIPHEN SAHOO SRE/Elect.	<i>Stephen</i>	JGM/L&U	<i>Stephen</i>

PROJECT:- HARYANA ORBITAL RAIL CORRIDOR
CONNECTING PALWAL TO SONIPAT BYPASSING DELHI AREA BY LINKING ASAOOTI-PATLI-SULTANPUR-ASAUDAH BY NEW ELECTRIFIED BG DOUBLE LINE

CLIENT:- HARYANA RAIL INFRASTRUCTURE DEVELOPMENT CORPORATION LIMITED.

GENERAL CONSULTANT:- GENERAL CONSULTANT FOR HARYANA ORBITAL RAIL CORRIDOR
RITES Limited in consortium with SMEC International Pty. Ltd.

GC/HORC DRG. NO:- GC-HRIDC-C4-DRW-TTL-CLT-01013_A1

DRAWING NAME: CONCEPTUAL DRAWING FOR PORTAL-2 & OPEN CUTTING AREA WITH 100M BALLASTLESS TRACK

ISSUE DATE: 07.11.2022 | REVISED DATE: 06.01.2023

SCALE: AS SHOWN

SMC DRG. NO:- SMC/HRIDC/TUNCS-7

CONSULTANT: S.M. CONSULTANTS (An ISO 9001 Company)

DESIGNER: SIVENDRA KUMAR TUNNEL DESIGNER (S.K. SHARMA)

PROJECT INCHARGE: A.A. SAMANT (A.A. SAMANT)

RELEASED FOR: PRELIMINARY FOR APPROVAL TENDER CONSTRUCTION

Minor Bridges

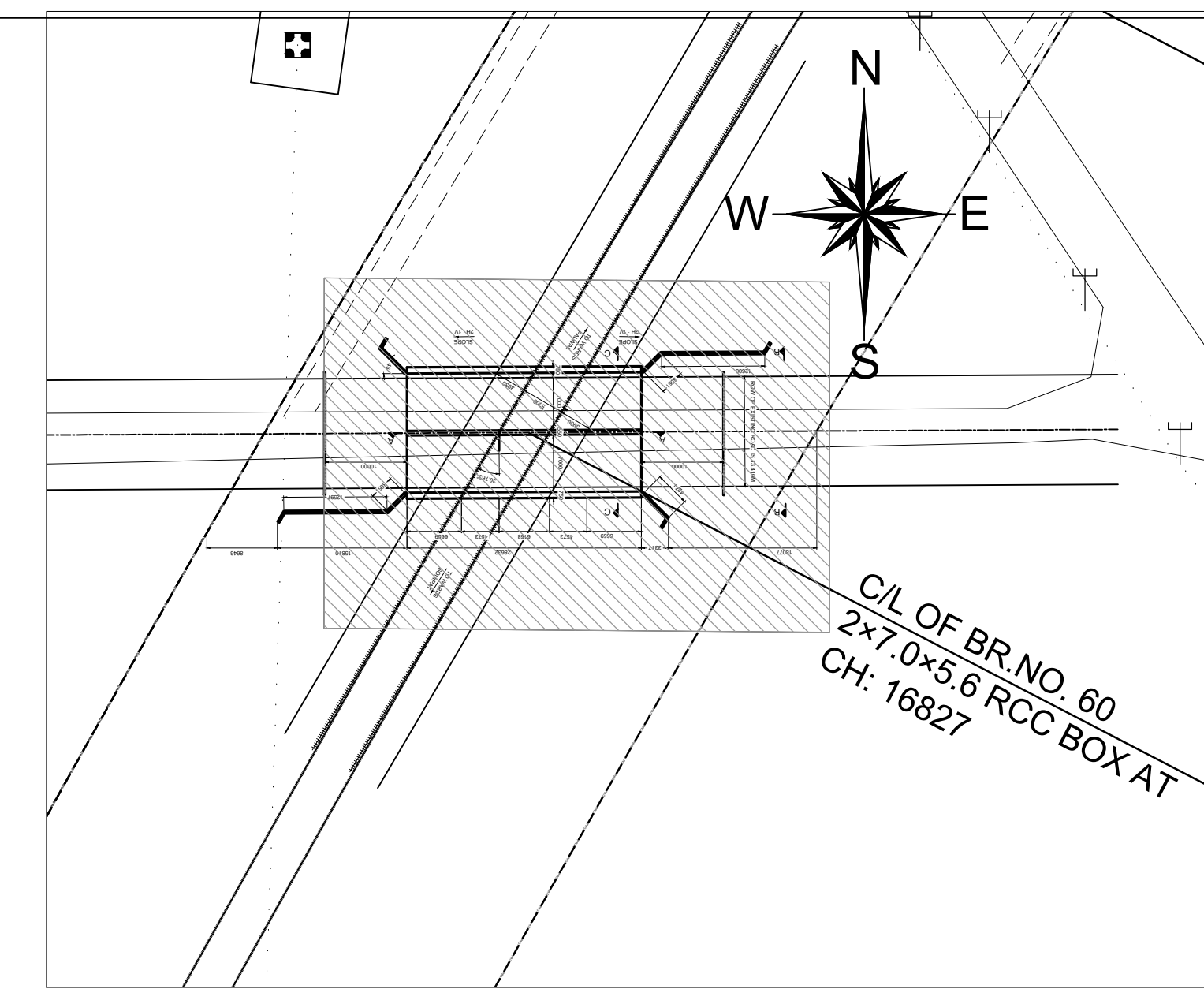
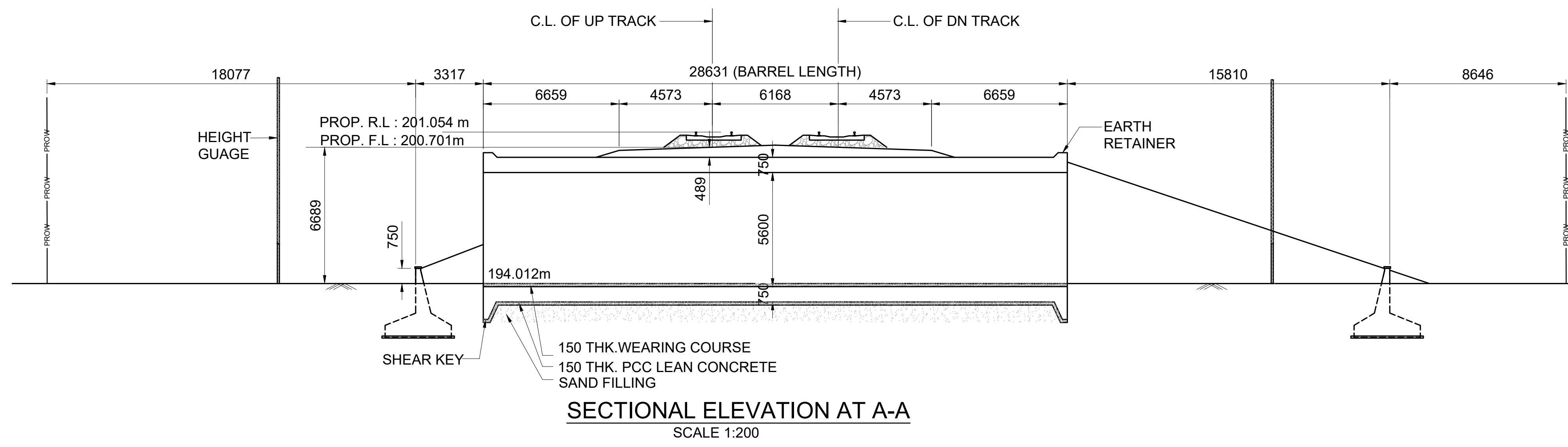

- NOTES :**
- A) GENERAL NOTES**
- ALL DIMENSIONS ARE IN MILLIMETERS EXCEPT LEVELS WHICH ARE IN METER, UNLESS OTHERWISE MENTIONED.
 - THE CHAINAGES SHOWN ARE RECKONED FROM C/L OF PRITHALA STATION BUILDING TAKEN AS 0.00 M, WITH RESPECT TO UP MAIN LINE.
 - FOR RAIL LEVELS, FORMATION LEVEL, GRADES ETC. REFER L-SECTION.
 - BOX BRIDGE IS TO BE DESIGNED FOR 32.5 T LOADING AS APPLICABLE.
 - THE EXISTING DETAILS ARE AS PER SITE SURVEY AND SHALL BE VERIFIED BY THE CONTRACTOR BEFORE EXECUTION.
 - ENGINEER IN CHARGE/ SITE ENGINEER SHOULD VERIFY THE RAIL LEVEL FORMATION LEVEL, BED LEVEL & TRACK CENTER AT SITE BEFORE COMMENCEMENT OF WORK.
 - SUITABLE BED SLOPE SHALL BE PROVIDED AND ADJUSTED AS PER SITE CONDITIONS.
 - ENGINEER IN CHARGE/SITE ENGINEER SHALL ENSURE THE SAFETY OF TRACK/ROAD AT ALL THE TIME AND SHALL TAKE NECESSARY PRECAUTIONS TO PREVENT DAMAGE OF S&T CABLE /OFC DURING EXECUTION OF WORK CONCERNED DEPT. SUCH AS BSNL/AIRTEL/SSE/SIG/ADSTE ETC. SHALL BE INFORMED WELL IN ADVANCE BEFORE EXECUTION OF WORK.
 - THIS DRAWING IS THE PROPERTY OF HRDC AND FOR EXCLUSIVE USE OF HORC.
 - DETAILED DESIGN DRAWING WILL BE PREPARED BASED ON THIS CONCEPTUAL APPROVED GAD.
 - THICKNESS OF STRUCTURAL MEMBERS ARE TENTATIVE AND WILL BE FINALISED AFTER DETAILED DESIGN.
- B) TECHNICAL NOTES :**
- PROTECTION WORK ON SLOPES OF BANK UP TO 15M BOTH SIDES ON APPROACHES OF BRIDGE SHALL BE DONE AS PER SKETCH NO. GC-HRDC-SK-GEN-015.
 - INSPECTION STEPS SHALL BE PROVIDED AT DIAGONALLY OPPOSITE ENDS OF THE BOX AFTER PROTECTION WORK.
 - FOR PROPER DRAINAGE OF WATER, 50mm PCC M-20 WITH SUITABLE SLOPE TO BE USED ON TOP OF BOX SLAB.
 - ALL CLEAN/ EXPANSION JOINTS SHALL BE FILLED WITH THERMOCOL.
 - PLACEMENT LEVEL OF BOX AS SHOWN IN THIS GAD IS INDICATIVE AND MAY BE SUITABLY LOWERED/ELEVATED BASED UPON THE REQUIREMENT OF CLEARANCE, DRAINAGE & NATURAL GROUND PROFILE.
 - DESIGN CRITERIA SHALL BE BASED ON FOLLOWING IRS CODES
 - IRS BRIDGE RULE
 - IRS CONCRETE BRIDGE CODE
 - IRS BRIDGE SUB-STRUCTURE & FOUNDATION CODE
 - SEISMIC ZONE- IV
 - EXPOSURE CONDITION- MODERATE.
 - DURING CONSTRUCTION, IF REQUIRED, ROAD CLOSURE TO BE OBTAINED FROM CONCERNED ROAD/CIVIL AUTHORITIES. DIVERSION OF ROAD IF ANY, REQUIRED IS TO BE DONE BY CONTRACTOR AT HIS COST.
 - THE BACK FILL MATERIAL SHALL BE CONFORMING TO CLAUSE 7.5 OF IRS SUB-STRUCTURE AND FOUNDATION CODE.
 - ALL RCC SURFACES COMING IN CONTACT WITH SOIL SHALL BE PAINTED WITH BITUMEN OR COAL TAR OF APPROVED QUALITY @ 1.464 K.G/SQM. CONFORMING TO IS-3117.
 - REINFORCEMENT SHALL BE Fe 500D (TMT) CONFORMING TO IS 1786.
 - FOR CONCRETE SPECIFICATION REFER IRS CONCRETE BRIDGE CODE. GRADE OF CONCRETE :
 - ALL RCC /WEARING COURSE(WC) =M:35/DETAILED DESIGN DRG.
 - LEVELING COURSE/LEAN CONCRETE =M:20/DETAILED DESIGN DRG.
 - BEARING CAPACITY OF SOIL SHALL BE ENSURED AS PER DETAILED DESIGN REQUIREMENT. GROUND IMPROVEMENT SHALL BE CARRIED OUT AS PER GT REPORT AND CONFIRMED THROUGH FIELD TESTING.
 - FOUNDATION LEVEL SHOWN IN DRAWING IS TENTATIVE. DETAILED DESIGN DRAWING SHALL BE FOLLOWED FOR FOUNDATION LEVEL DURING EXECUTION.
 - HEIGHT GAUGE SHALL BE PROVIDE AS PER RDSO STANDARD DRAWING NO. RDSO/M0001.
 - SPEED BREAKER SHOULD BE PROVIDED ON EITHER APPROACH OF RUB AT A DISTANCE OF 20M FROM THE BRIDGE COVERING FULL WIDTH OF THE ROAD INCLUDE BERMS.

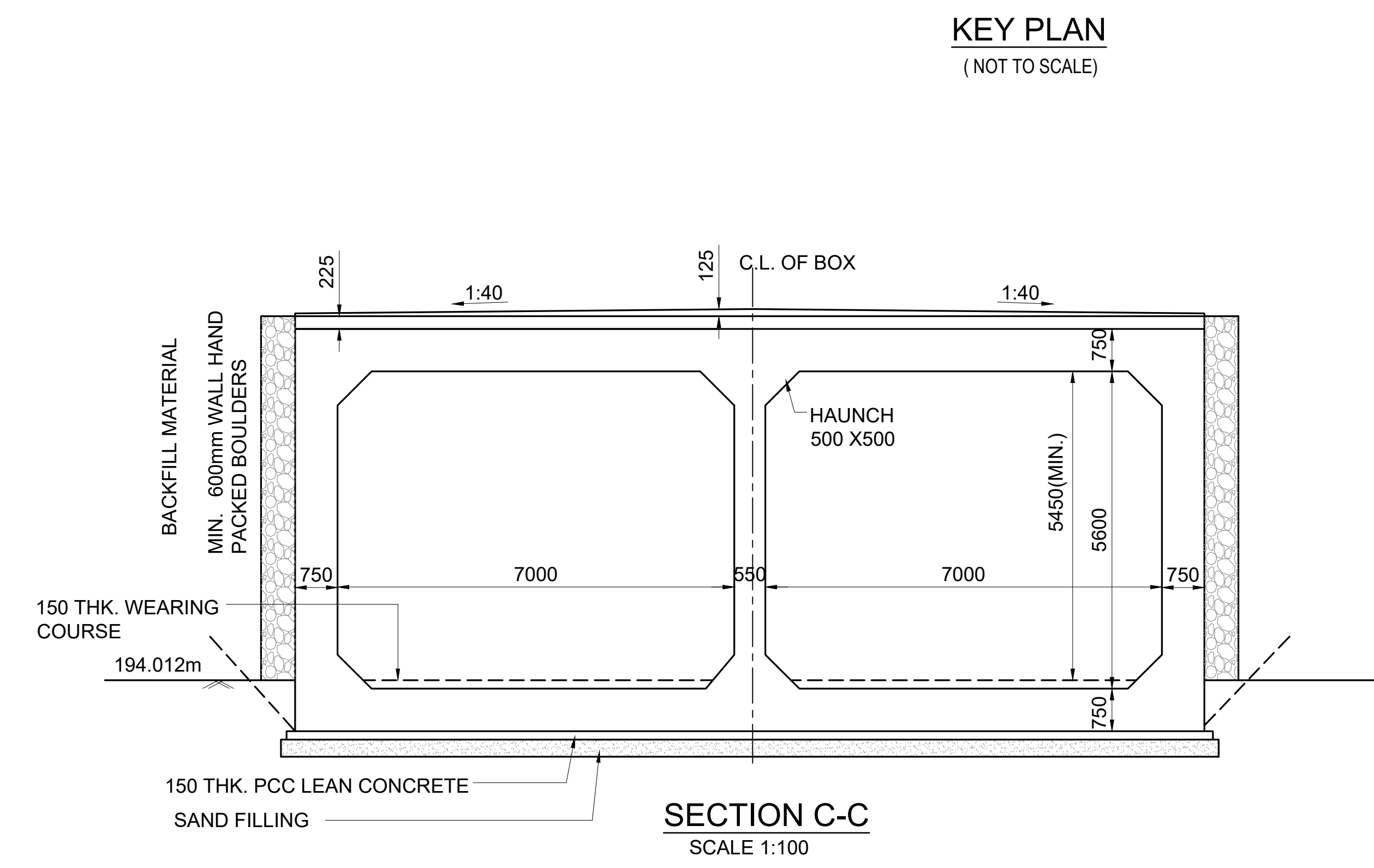
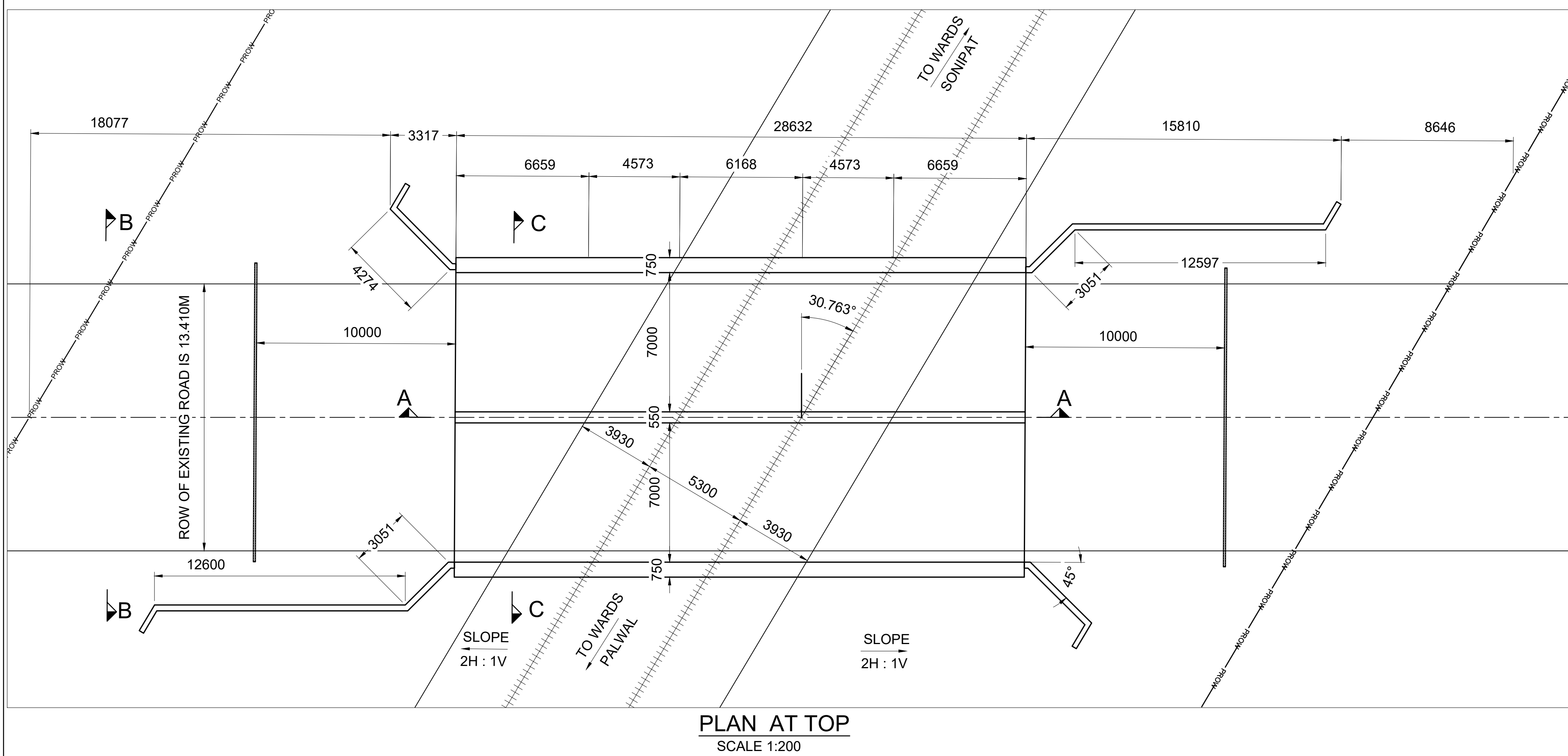

- ALL RCC /WEARING COURSE(WC) =M:35/DETAILED DESIGN DRG.
- LEVELING COURSE/LEAN CONCRETE =M:20/DETAILED DESIGN DRG.
- BEARING CAPACITY OF SOIL SHALL BE ENSURED AS PER DETAILED DESIGN REQUIREMENT. GROUND IMPROVEMENT SHALL BE CARRIED OUT AS PER GT REPORT AND CONFIRMED THROUGH FIELD TESTING.
- FOUNDATION LEVEL SHOWN IN DRAWING IS TENTATIVE. DETAILED DESIGN DRAWING SHALL BE FOLLOWED FOR FOUNDATION LEVEL DURING EXECUTION.
- HEIGHT GAUGE SHALL BE PROVIDE AS PER RDSO STANDARD DRAWING NO. RDSO/M0001.
- SPEED BREAKER SHOULD BE PROVIDED ON EITHER APPROACH OF RUB AT A DISTANCE OF 20M FROM THE BRIDGE COVERING FULL WIDTH OF THE ROAD INCLUDE BERMS.

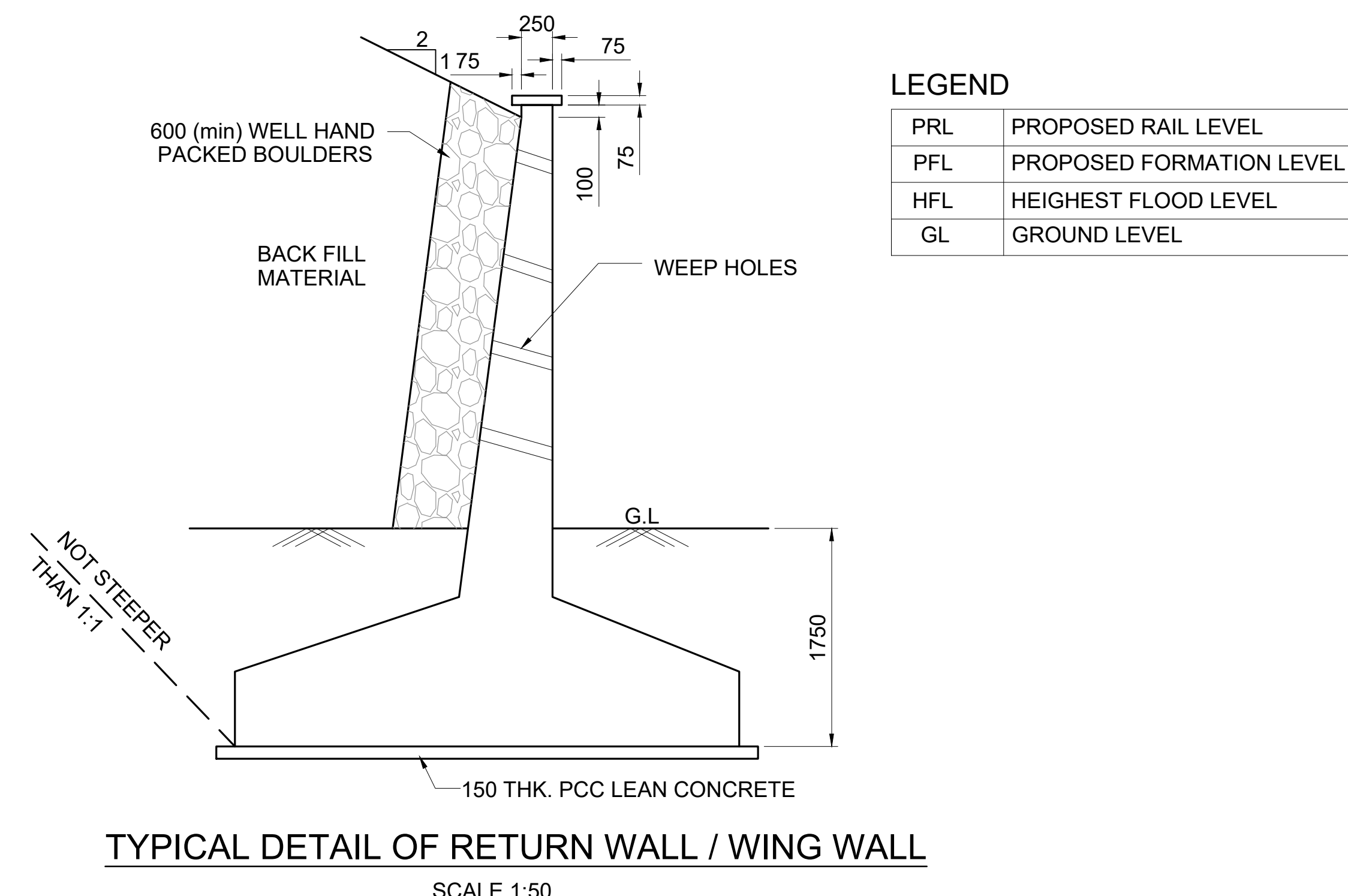
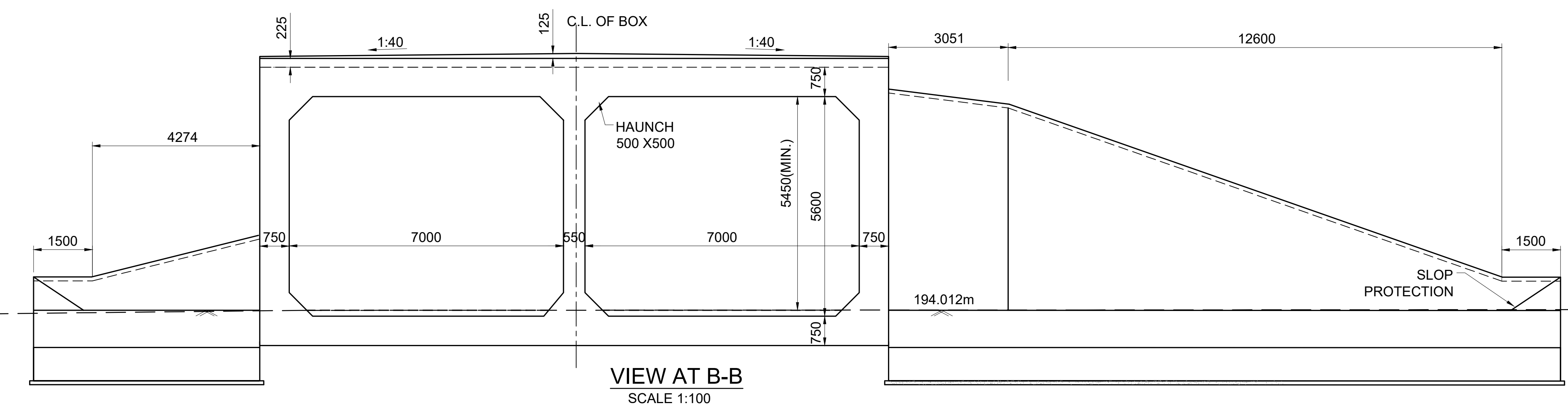

LEGEND

PRL	PROPOSED RAIL LEVEL
PFL	PROPOSED FORMATION LEVEL
HFL	HIGHEST FLOOD LEVEL
GL	GROUND LEVEL

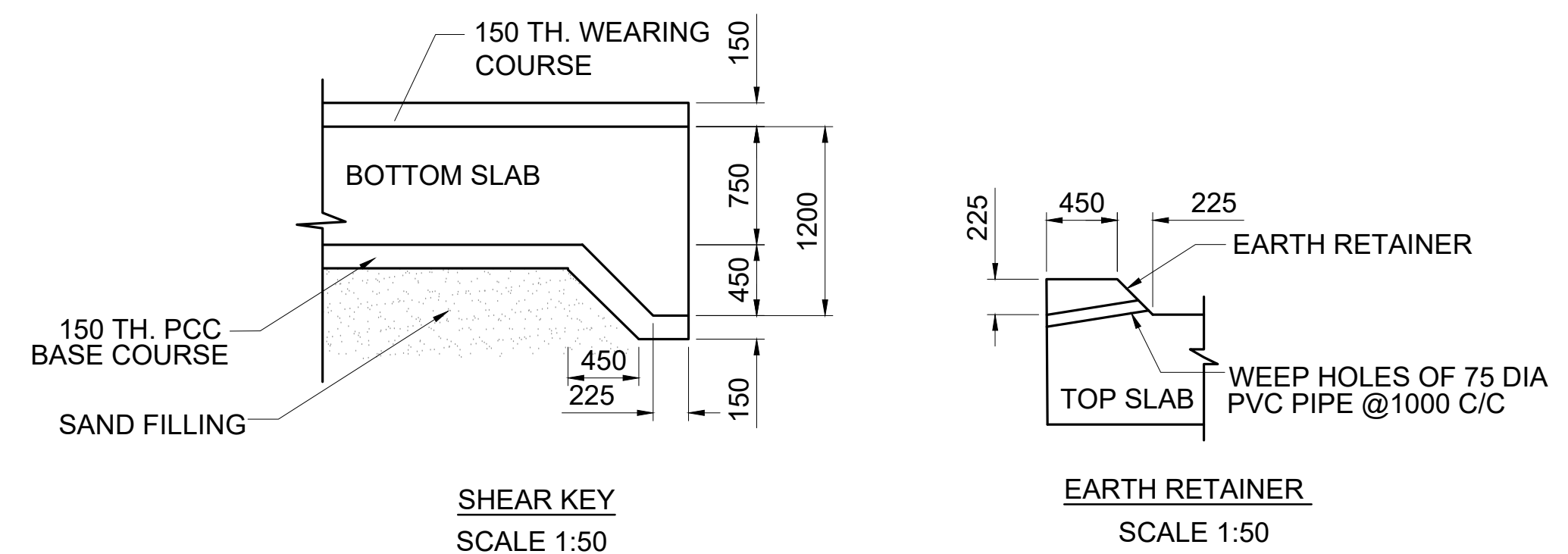

GC/HORC		HRDC	
NAME / DESIGNATION	SIGN	NAME / DESIGNATION	SIGN
CHAHATEY RAM PD	<i>Chahatey Ram</i>	SHIV OM DWIVEDI CPM/HRDC	<i>Shiv</i>
SUDHIR AGRAWAL DPD/CIVIL	<i>Sudhir</i>	RAJU SOLANKI DGM/CIVIL/SOUTH	<i>Raju</i>
REETU PATIAL CDE/ CIVIL	<i>Reetu</i>		

PROJECT:
HARYANA ORBITAL RAIL CORRIDOR
CONNECTING PALWAL TO SONIPAT BYPASSING DELHI AREA BY LINKING ASAOTI-PATLI-SULTANPUR-ASAUDAH BY NEW ELECTRIFIED BG DOUBLE LINE

CLIENT:
 HARYANA RAIL INFRASTRUCTURE DEVELOPMENT CORPORATION LIMITED.

CONSULTANT:
 GENERAL CONSULTANT FOR HARYANA ORBITAL RAIL CORRIDOR
RITES Limited in consortium with SMCC International Pty. Ltd.



TITLE:- CONCEPTUAL GENERAL ARRANGEMENT DRAWING
PROPOSED RUB NO. 060
SPAN 2x7.0x5.6 RCC BOX AT CH: 16827

DRG. NO. GC-HRDC-C4-DRW-BRD-GAD-01060_A2
SHEET NO. 1 OF 1

SCALE : AS SHOWN
ISSUE DATE 07-11-2022
REVISED DATE 10-01-2023

Major Bridges

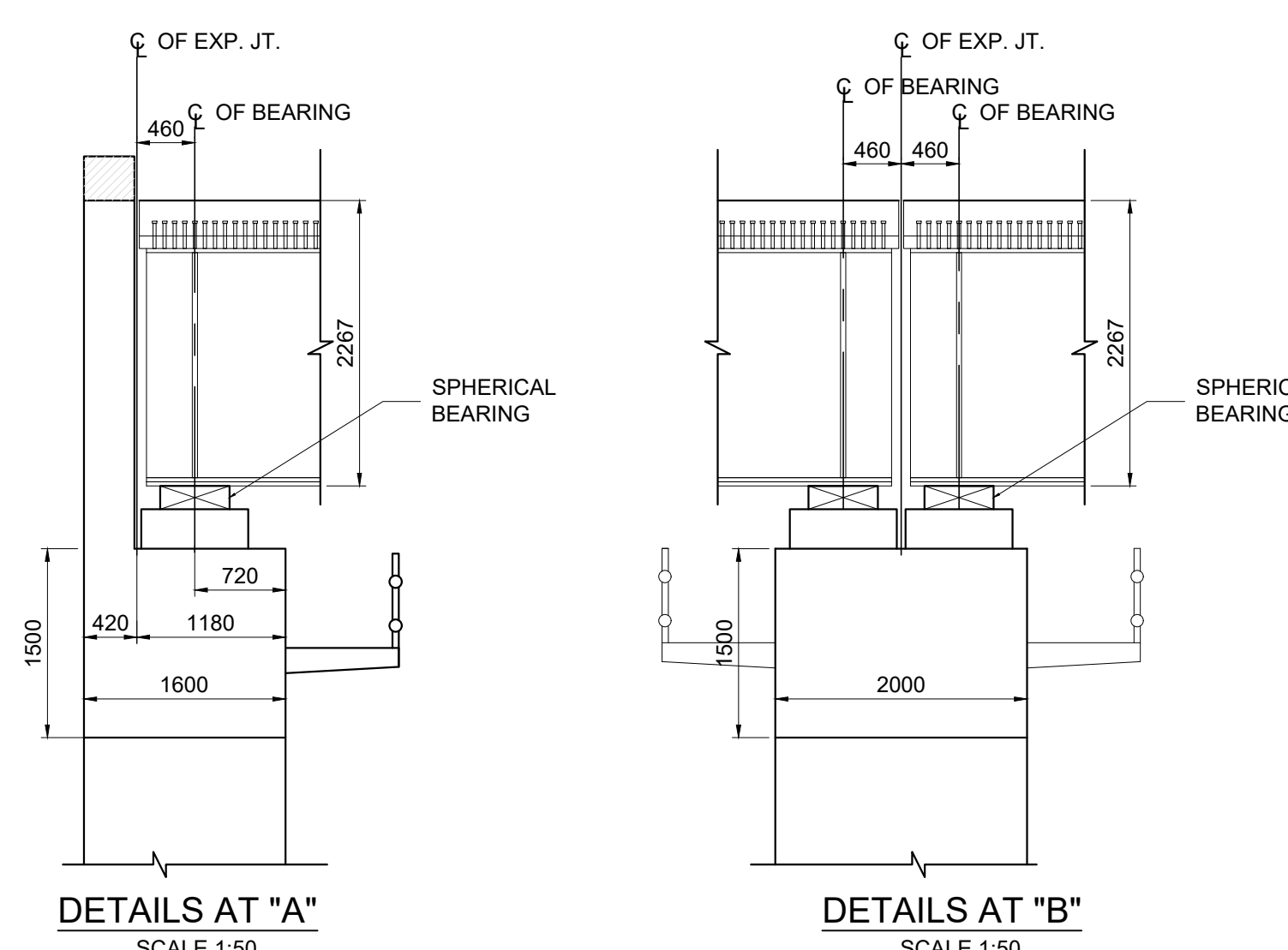
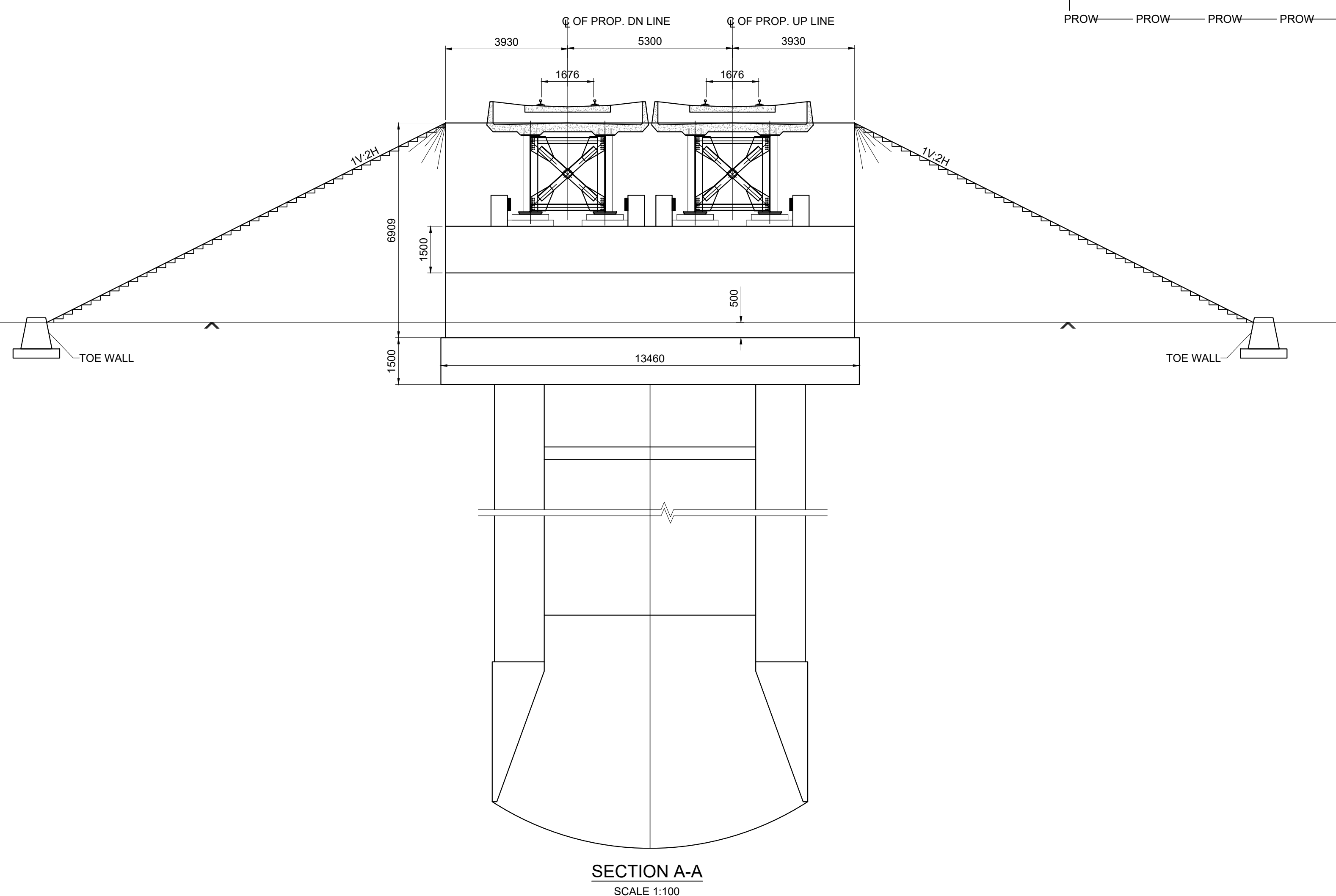
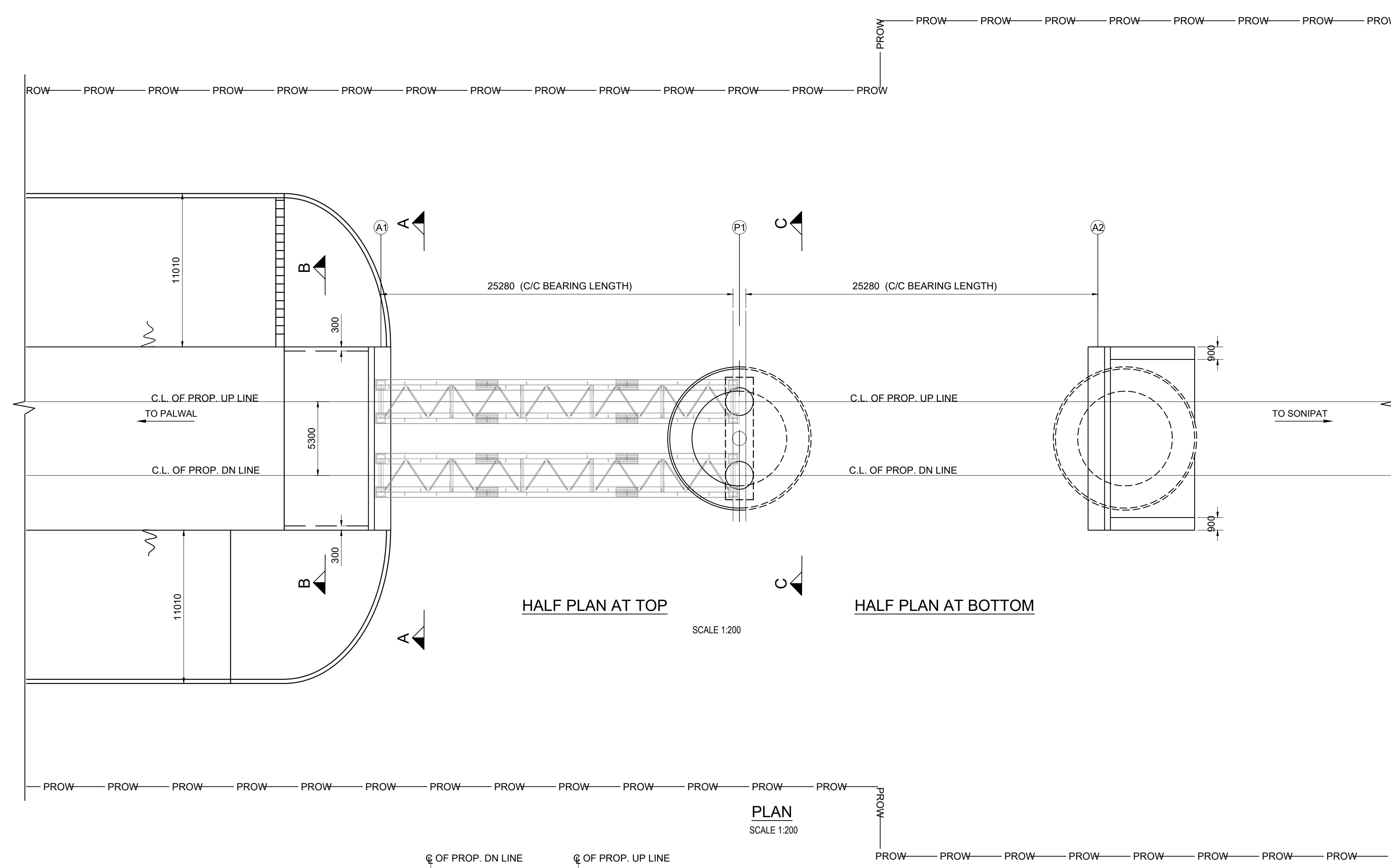
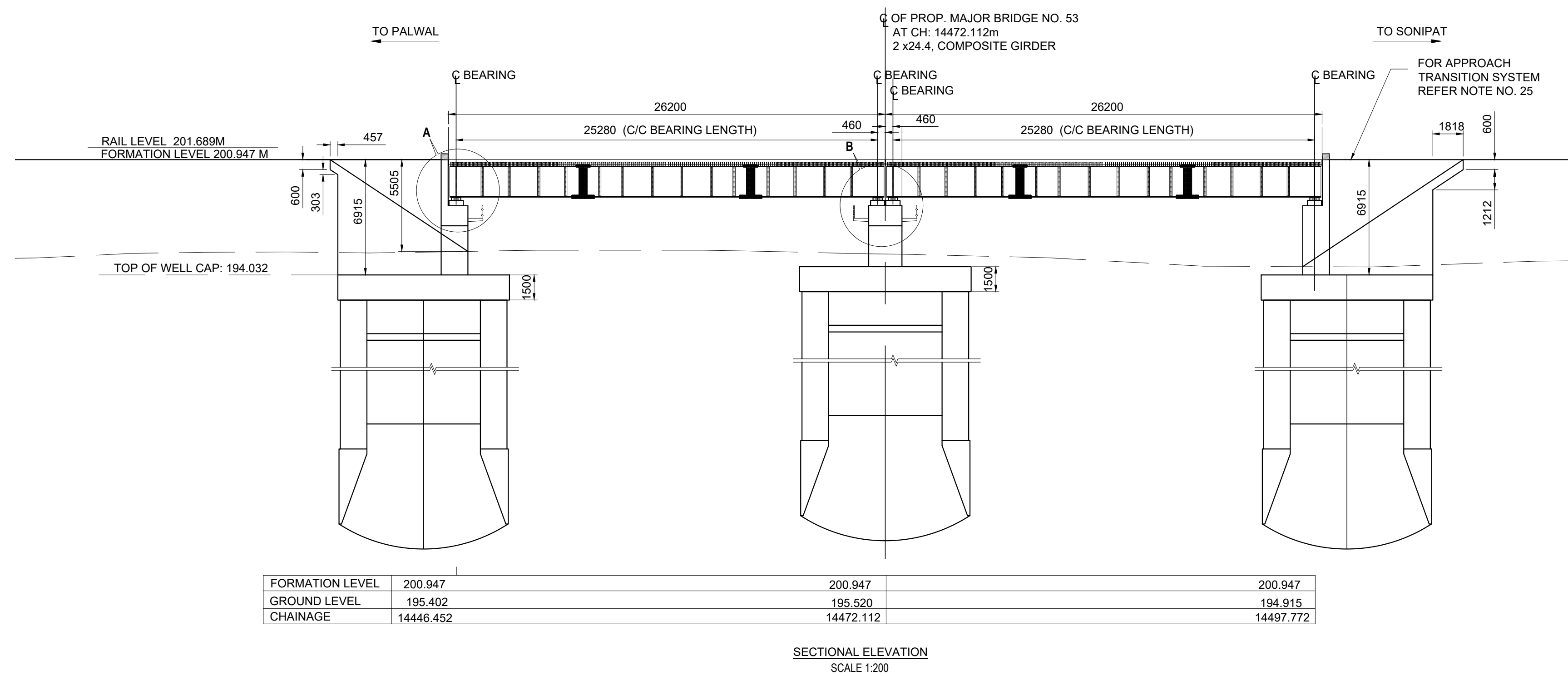

GC/HORC		HRIDC	
NAME / DESIGNATION	SIGN	NAME / DESIGNATION	SIGN
CHAHATEY RAM PD	<i>Chahatey Ram</i>	SHIV OM DWIVEDI CPM/HRIDC	<i>Shiv</i>
SUDHIR AGRAWAL DPD/CIVIL	<i>MS</i>	RAJU SOLANKI DGM/CIVIL/SOUTH	<i>Raju</i>
REETU PATIAL CDE/ CIVIL	<i>Reetu</i>		

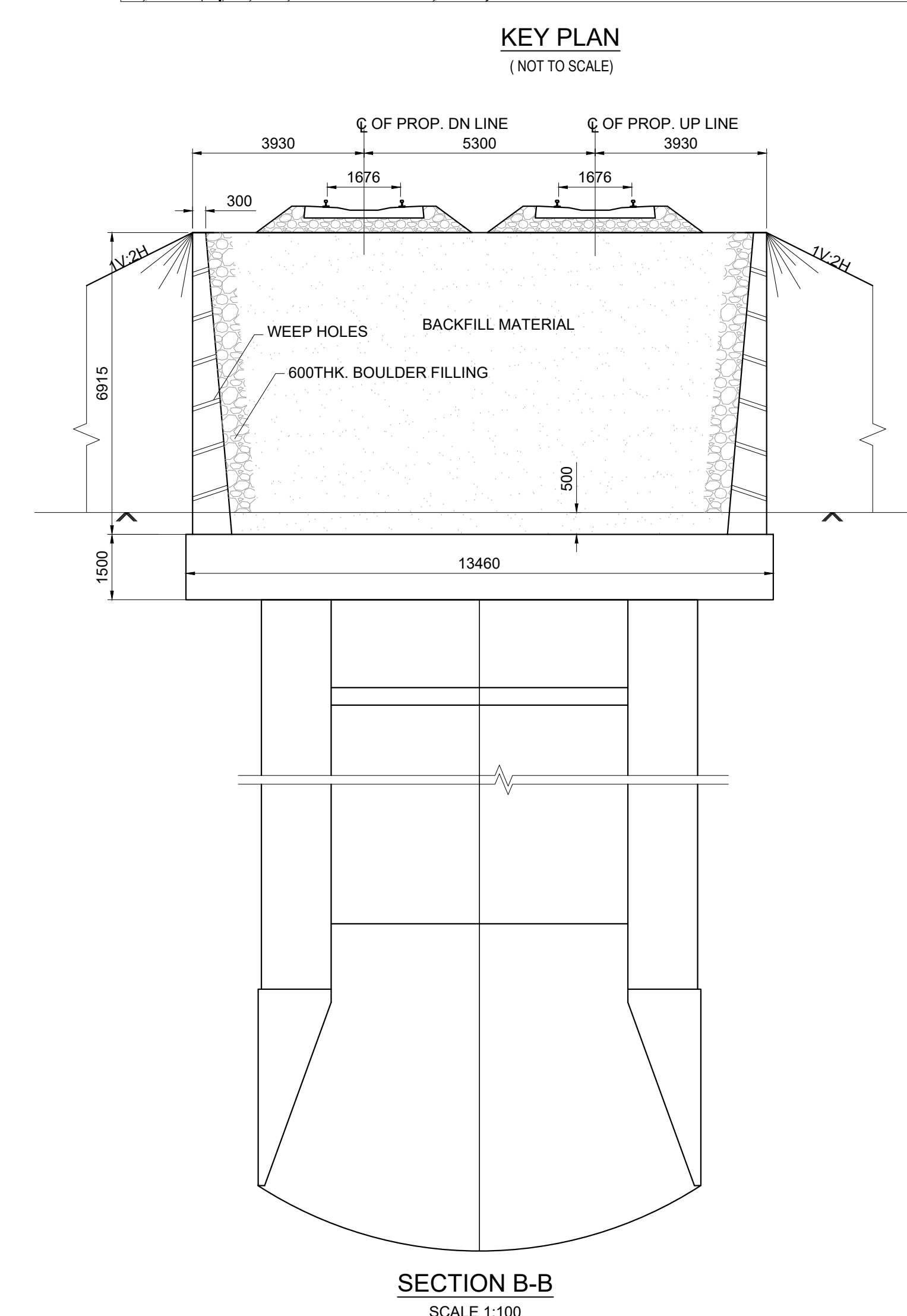
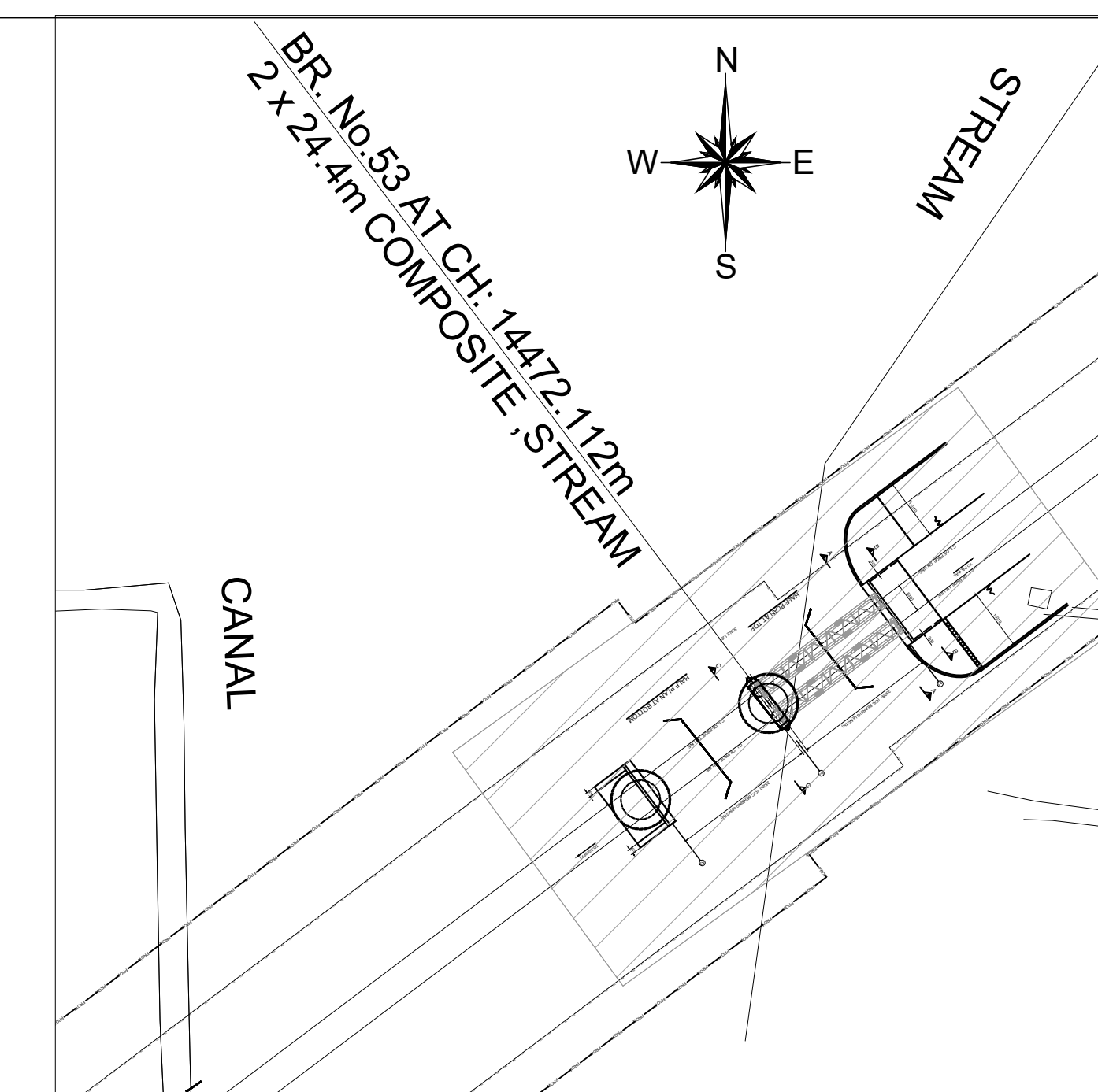

- NOTES:
- ALL DIMENSIONS ARE IN MILLIMETERS AND LEVELS ARE IN METER
 - DIMENSIONS ARE NOT TO BE SCALED ONLY WRITTEN DIMENSIONS TO BE FOLLOWED
 - DESIGN CRITERIA
 - IRS BRIDGE SUBSTRUCTURE AND FOUNDATION CODE 2013.
 - IRS CONCRETE BRIDGE CODE 2014.
 - IRS BRIDGE RULES 2014.
 - IS 2911 PART-1 SECTION-2
 - EXPOSURE CONDITION - MODERATE.
 - SEISMIC ZONE - IV
 - STANDARD OF LOADING - SUPER STRUCTURE-25T (RDSO STANDARD CG) & SUB STRUCTURE-32-ST-2008 LOADING
 - THE STRUCTURAL DIMENSIONS SHOWN IS TENTATIVE AND MAY CHANGE DURING DETAILED DESIGN.
 - ALL RCC AND CC WORKS SHALL BE DONE IN ACCORDANCE WITH SPECIFICATION LAID DOWN IN IRS CONCRETE BRIDGE CODE.
 - THE GRADE OF CONCRETE
 - FOR ABUTMENT DIRT & RETURN WALL WEARING COURSE(WC)-----M35
 - FOR FOUNDATION-----M35
 - FOR LEVELING COURSE-----M20
 - ALL CONCRETE WORK SHALL BE MECHANICALLY MIXED AND VIBRATED.
 - MIX DESIGN SHALL BE APPROVED BY ENGINEER - IN CHARGE.
 - HIGH YIELD STRENGTH DEFORMED BARS OF GRADE Fe-500D CONFORMING TO IS: 1786-2008 SHALL BE USED AS REINFORCEMENT.
 - BED LEVEL & ROAD LEVEL FORMATION LEVEL AND RAIL LEVEL & ALIGNMENT SHALL BE VERIFIED BY THE ENGINEER AT SITE BEFORE EXECUTION OF WORK.
 - ANGLE OF INTERNAL FRICTION OF BACK FILL SHALL NOT BE LESS THAN 35.
 - PROTECTION WORK ON SLOPES OF BANK UP TO 30M BOTH SIDES ON APPROACHES OF BRIDGE SHALL BE DONE AS PER SKETCH NO. GC-HRIDC-SK-GEN-015.
 - BACK FILL BEHIND RETURN WALL/WING WALL SHALL BE AS PER CL 7.5 OF IRS BRIDGE SUBSTRUCTURE & FOUNDATION CODE 2013. BOULDER FILLING & BOULDER PACKING BEHIND RETURN WALL/WING WALL TO BE DONE AS PER IRS FOUNDATION & SUBSTRUCTURE CODE CL 7.5.2. ALL RCC SURFACES COMING IN CONTACT WITH SOIL SHOULD BE PAINTED WITH BITUMEN OR COAL TAR OF APPROVED QUALITY @ 1.464 KG/SQM CONFORMING TO IS-317.
 - CURING SHALL BE DONE AS PER CLAUSE NO 8.4 OF IRS CONCRETE BRIDGE CODE.
 - SAFETY & PROTECTION OF THE PROPOSED WORK IS TO BE ENSURED BY THE CONTRACTOR AS PER PARA 826 OF IRPMM WITH UPDATED CORRECTION SLIPS OF 2011-12.
 - THE SPECIFICATIONS FOR THE COMPOSITE GIRDER SHALL BE IN ACCORDANCE WITH RDSO DRG NO'S : RDSO B-1175/1R1 TO 1175/1B.
 - CONCRETING SHALL BE DONE IN ACCORDANCE WITH IRS CONCRETE BRIDGE CODE WITH 20MM MAXIMUM SIZE AGGREGATE.
 - ALL DIMENSIONS AND LEVELS SHOULD BE VERIFIED AT SITE BEFORE EXECUTION.
 - BRIDGE DETAILS LIKE : DL, INSPECTION STEPS PAINTINGS ETC SHOULD BE FOLLOWED AS PER BRIDGE MANUAL DURING CONSTRUCTION.
 - THIS DRAWING IS PROPERTY OF HARYANA RAIL INFRASTRUCTURE DEVELOPMENT CORPORATION LIMITED (HRIDC) AND EXCLUSIVE USE OF HRIDC.
 - ARRANGEMENT FOR PATHWAY SHALL BE PROVIDED AS PER RDSO DWG. NO. CBS-0046 (FOR CG).
 - SEISMIC ARRESTOR SHALL BE PROVIDED ON THE PIER/ABUTMENT CAP.
 - TRANSITION SYSTEM TO BE ADOPTED ON BRIDGE APPROACHES SHALL BE AS PER RDSO REPORT NO. GE-R-50/TRANSITION SYSTEM ON APPROACHES OF BRIDGES). FOR DETAILS REFER SKETCH NO. GC-HRIDC-SK-GEN-019.

PROJECT:
HARYANA ORBITAL RAIL CORRIDOR
 CONNECTING PALWAL TO SONIPAT BYPASSING DELHI AREA BY LINKING ASAOTI-PATLI-SULTANPUR-ASAUDAH BY NEW ELECTRIFIED BG DOUBLE LINE

CLIENT:
HARYANA RAIL INFRASTRUCTURE DEVELOPMENT CORPORATION LIMITED.

CONSULTANT:
GENERAL CONSULTANT FOR HARYANA ORBITAL RAIL CORRIDOR
 RITES Limited in consortium with SMEC International Pty. Ltd.

IRITES THE INFRASTRUCTURE PEOPLE **SMEC** Member of the Surbana Jurong Group

TITLE:- **CONCEPTUAL GENERAL ARRANGEMENT DRAWING**
 FOR STREAM BRIDGE NO.53
 2x24.4 CG AT CH: 14472.112m

DRG. NO. GC-HRIDC-C4-DRW-BRD-GAD-01053_A2 SHEET NO. 1 OF 1

SCALE : AS SHOWN ISSUE DATE 07-11-2022 REVISED DATE 10-01-2023

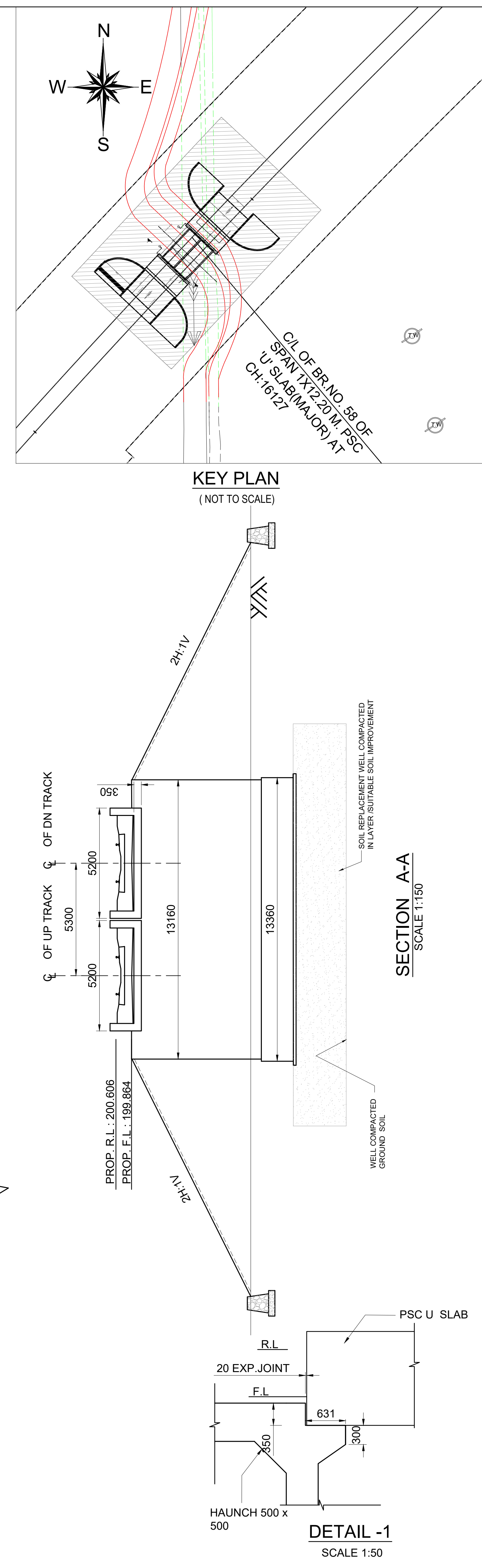
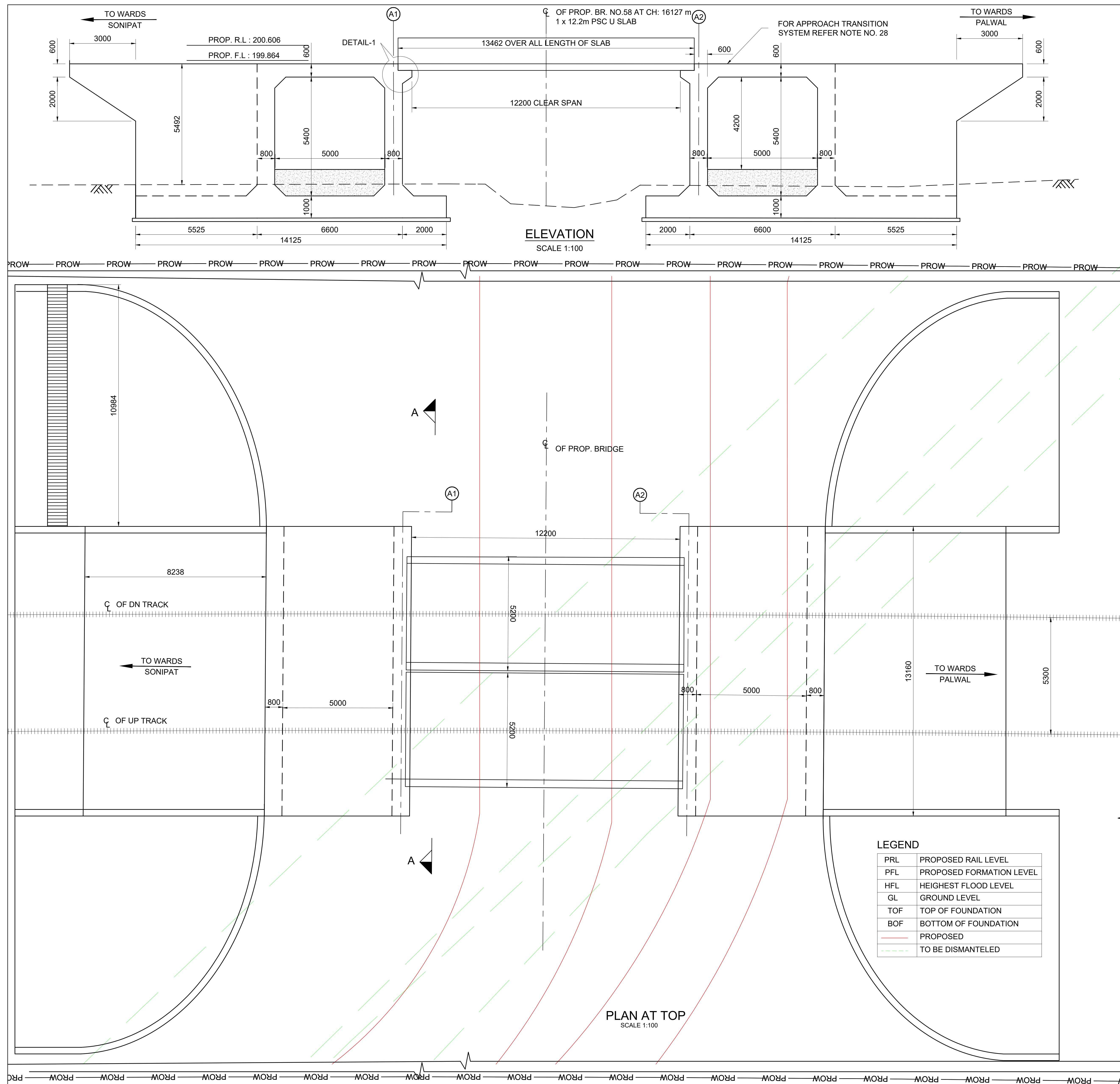

- NOTES:**
- ALL DIMENSIONS ARE IN MILLIMETERS AND LEVELS ARE IN METER DIMENSIONS ARE NOT TO BE SCALED ONLY WRITTEN DIMENSIONS TO BE FOLLOWED
 - DESIGN CRITERIA
 - IRS BRIDGE SUBSTRUCTURE AND FOUNDATION CODE 2013.
 - IRS CONCRETE BRIDGE CODE 2014.
 - IRS BRIDGE RULES 2014.
 - IS 2911 PART-1 SECTION-2.
 - EXPOSURE CONDITION - MODERATE.
 - SEISMIC ZONE - IV
 - STANDARD OF LOADING - SUPER STRUCTURE-25T (RDSO STANDARD) & SUB STRUCTURE-32.5T-2008 LOADING.
 - THE STRUCTURAL DIMENSIONS AND SIZES ARE INDICATIVE AND THESE MAY VARY DURING DETAIL DESIGN.
 - SIZE & TYPE OF FOUNDATION SHOWN IS TENTATIVE AND MAY CHANGE DURING DETAILED DESIGN.
 - ALL RCC AND CC WORKS SHALL BE DONE IN ACCORDANCE WITH SPECIFICATION LAID DOWN IN IRS CONCRETE BRIDGE CODE.
 - THE GRADE OF CONCRETE
 - FOR ABUTMENT, DIRT & RETURN WALL WEARING COURSE(WC)---M35
 - FOR FOUNDATION
 - FOR LEVELING COURSE
 - ALL CONCRETE WORK SHALL BE MECHANICALLY MIXED AND VIBRATED.
 - MIX DESIGN SHALL BE APPROVED BY ENGINEER - IN CHARGE.
 - HIGH YIELD STRENGTH DEFORMED BARS OF GRADE Fe-500D CONFORMING TO IS: 1786-2008 SHALL BE USED AS REINFORCEMENT.
 - BED LEVEL & ROAD LEVEL, FORMATION LEVEL AND RAIL LEVEL & ALIGNMENT SHALL BE VERIFIED BY THE ENGINEER AT SITE BEFORE EXECUTION OF WORK.
 - ANGLE OF INTERNAL FRICTION OF BACK FILL SHALL NOT BE LESS THAN 35.
 - PROTECTION WORK ON SLOPES OF BANK UP TO 30M, BOTH SIDES ON APPROACHES OF BRIDGE SHALL BE DONE AS PER SKETCH NO. GC-HRIDC-SK-GEN-015.
 - BOULDER FILLING & BOULDER PACKING BEHIND RETURN WALL/WING WALL TO BE DONE AS PER IRS FOUNDATION & SUBSTRUCTURE CODE CL.7.5.2.
 - BACK FILL BEHIND RETURN WALL/WING WALL SHALL BE AS PER CL.7.5 OF IRS BRIDGE SUBSTRUCTURE & FOUNDATION CODE 2013.
 - 75mm DIA WEEP HOLES TO BE PROVIDED @1000 C/C HORZ. AND 1000 MM C/C VERTICALLY ABOVE LOWEST WATER LEVEL IN RETURN WALL AS PER IRS SUB STRUCTURE CODE CLAUSE 7.6.
 - ALL RCC SURFACES COMING IN CONTACT WITH SOIL SHOULD BE PAINTED WITH BITUMEN OR COAL TAR OF APPROVED QUALITY @ 1.464 KG/SQM. CONFORMING TO IS-3117.
 - CURING SHALL BE DONE AS PER CLAUSE NO 8.4 OF IRS CONCRETE BRIDGE CODE.
 - SAFETY & PROTECTION OF THE PROPOSED WORK IS TO BE ENSURED BY THE CONTRACTOR AS PER PARA 826 OF IRPWW WITH UPDATED CORRECTION SLIPS OF 2011-12.
 - THE SPECIFICATIONS FOR THE PSC U SLAB SHALL BE IN ACCORDANCE WITH RDSO DRG. NO'S : RDSO 10281, 10281/1 AND 10281/2.
 - CONCRETING SHALL BE DONE IN ACCORDANCE WITH IRS CONCRETE BRIDGE CODE WITH 20MM MAXIMUM SIZE AGGREGATE.
 - ALL DIMENSIONS AND LEVELS SHOULD BE VERIFIED AT SITE BEFORE EXECUTION.
 - BRIDGE DETAILS LIKE , DL, INSPECTION STEPS PAINTINGS ETC SHOULD BE FOLLOWED AS PER BRIDGE MANUAL DURING CONSTRUCTION.
 - THIS DRAWING IS PROPERTY OF HARYANA RAIL INFRASTRUCTURE DEVELOPMENT CORPORATION LIMITED (HRIDC) AND EXCLUSIVE USE OF HRIDC.
 - FOR TOE WALL DETAILS REFER SEPARATE SKETCH NO. GC-HRIDC-SK-GEN-014.
 - BEARING CAPACITY OF SOIL SHALL BE ENSURED AS PER DETAILED DESIGN REQUIREMENT. SUITABLE GROUND IMPROVEMENT SHALL BE CARRIED OUT AS PER GT & DESIGN REQUIREMENT AND CONFIRMED THROUGH FIELD TESTING.
 - SMOOTH TRANSITION SHALL BE PROVIDED BETWEEN THE EXISTING LINED CANAL/DRAIN AND THE BOX.
 - TRANSITION SYSTEM TO BE ADOPTED ON BRIDGE APPROACHES SHALL BE AS PER RDSO REPORT NO. GE-R-50 (TRANSITION SYSTEM ON APPROACHES OF BRIDGES). FOR DETAILS REFER SKETCH NO. GC-HRIDC-SK-GEN-019.

PROJECT:
HARYANA ORBITAL RAIL CORRIDOR
 CONNECTING PALWAL TO SONIPAT BYPASSING DELHI AREA BY LINKING ASAOTI-PATLI-SULTANPUR-ASAUDAH BY NEW ELECTRIFIED BG DOUBLE LINE

CLIENT:
HARYANA RAIL INFRASTRUCTURE DEVELOPMENT CORPORATION LIMITED.

CONSULTANT:
GENERAL CONSULTANT FOR HARYANA ORBITAL RAIL CORRIDOR
 RITES Limited in consortium with SMEC International Pty. Ltd.

SMEC
 Member of the Surbana Jurong Group

HYDRAULIC DATA OF DISTRIBUTARY

1	NAME OF MINOR	INDRI DISTRIBUTARY
2	RD	2650/16127
3	FREE BOARD	0.45
4	DISCHARGE	45.02 Cusec
5	BED WIDTH	a 2.088
6	F.S.D	b 1.19
7	SIDE SLOPE	1.5:1
8	TOP WIDTH	c 5.65
9	SHAPE	

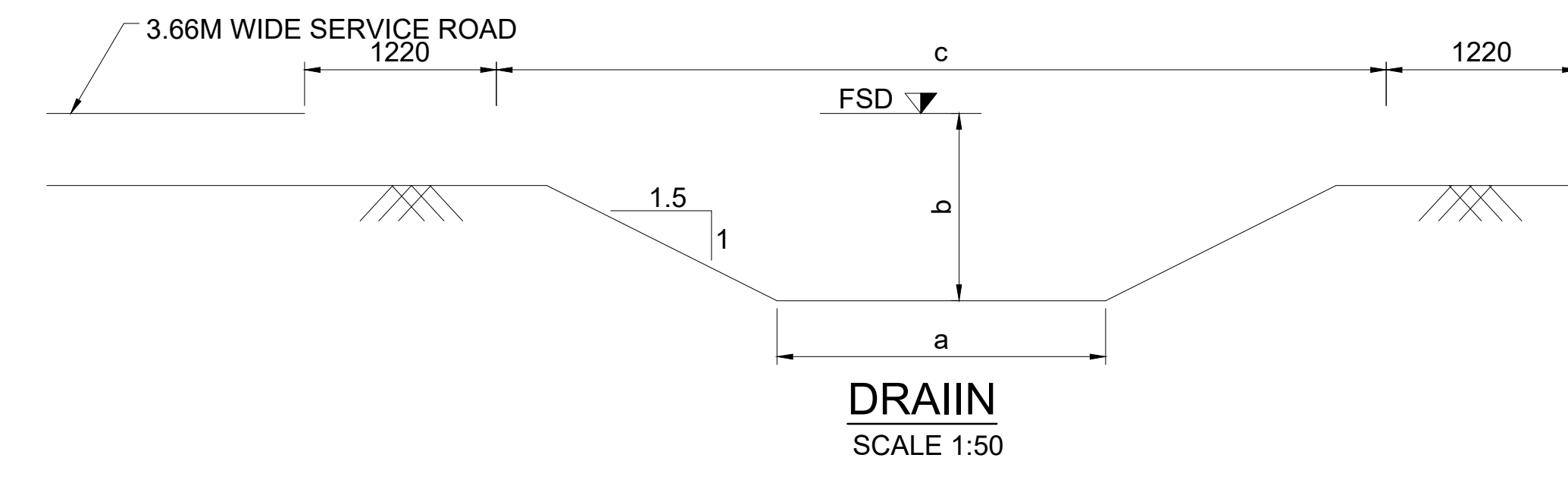

GC/HORC

NAME / DESIGNATION	SIGN
CHAHATEY RAM PD	<i>Chahatey Ram</i>
SUDHIR AGRAWAL DPD/CIVIL	<i>MS</i>
REETU PATIAL CDE/ CIVIL	<i>RE</i>

HRIDC

NAME / DESIGNATION	SIGN
SHIV OM DWIVEDI CPM/HRIDC	<i>Shiv</i>
RAJU SOLANKI DGM/CIVIL/SOUTH	<i>Raju</i>

TITLE:- **CONCEPTUAL GENERAL ARRANGEMENT DRAWING**
 FOR CANAL BR.NO. 058
 1 x 5 x 5.4m + 1 x 12.2m + 1 x 5 x 5.4m PSC U SLAB CH: 16127

DRG. NO. GC-HRIDC-C4-DRW-BRD-GAD-01058_A2 **SHEET NO.** 1 OF 1

SCALE : AS SHOWN **ISSUE DATE** 07-11-2022 **REVISED DATE** 10-01-2023

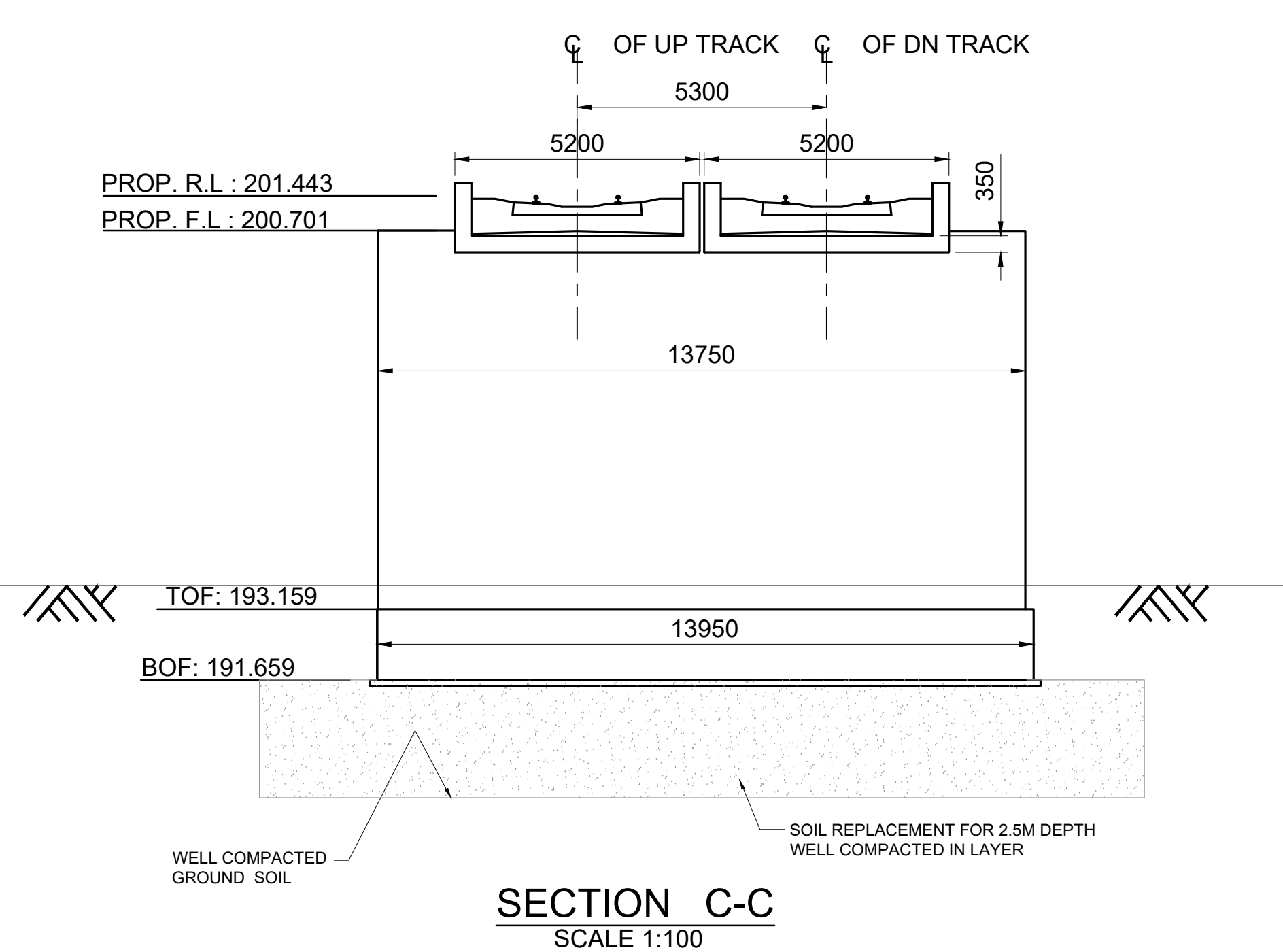
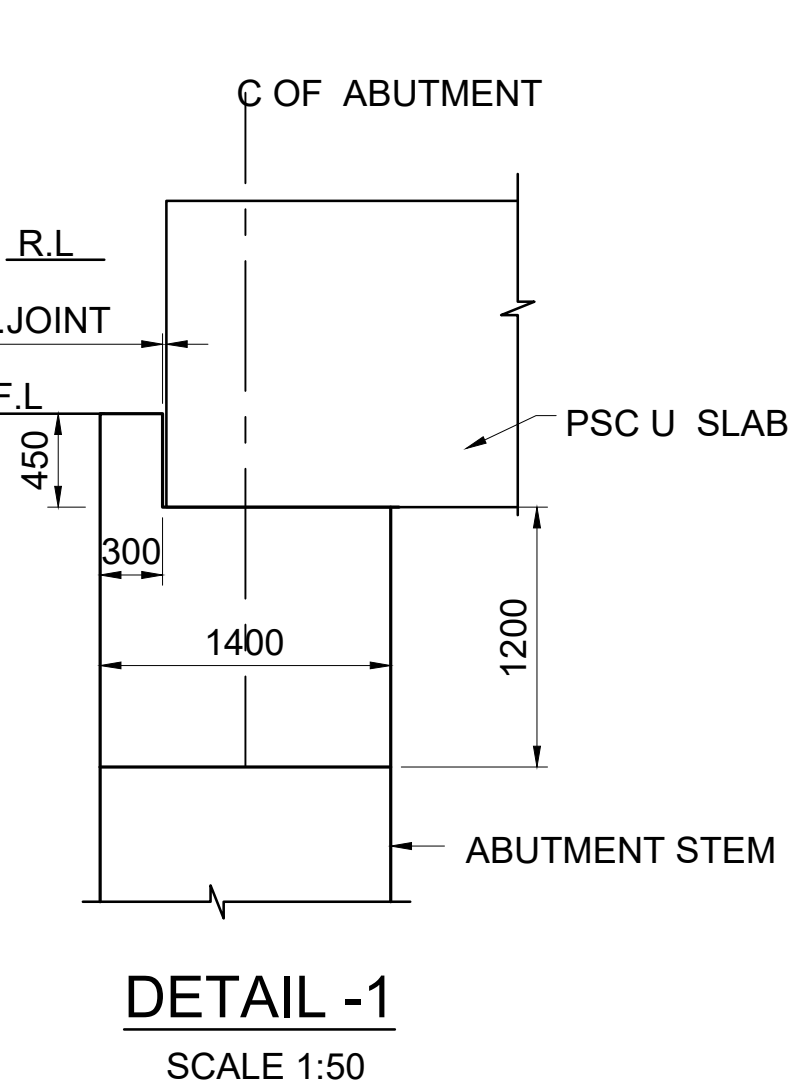
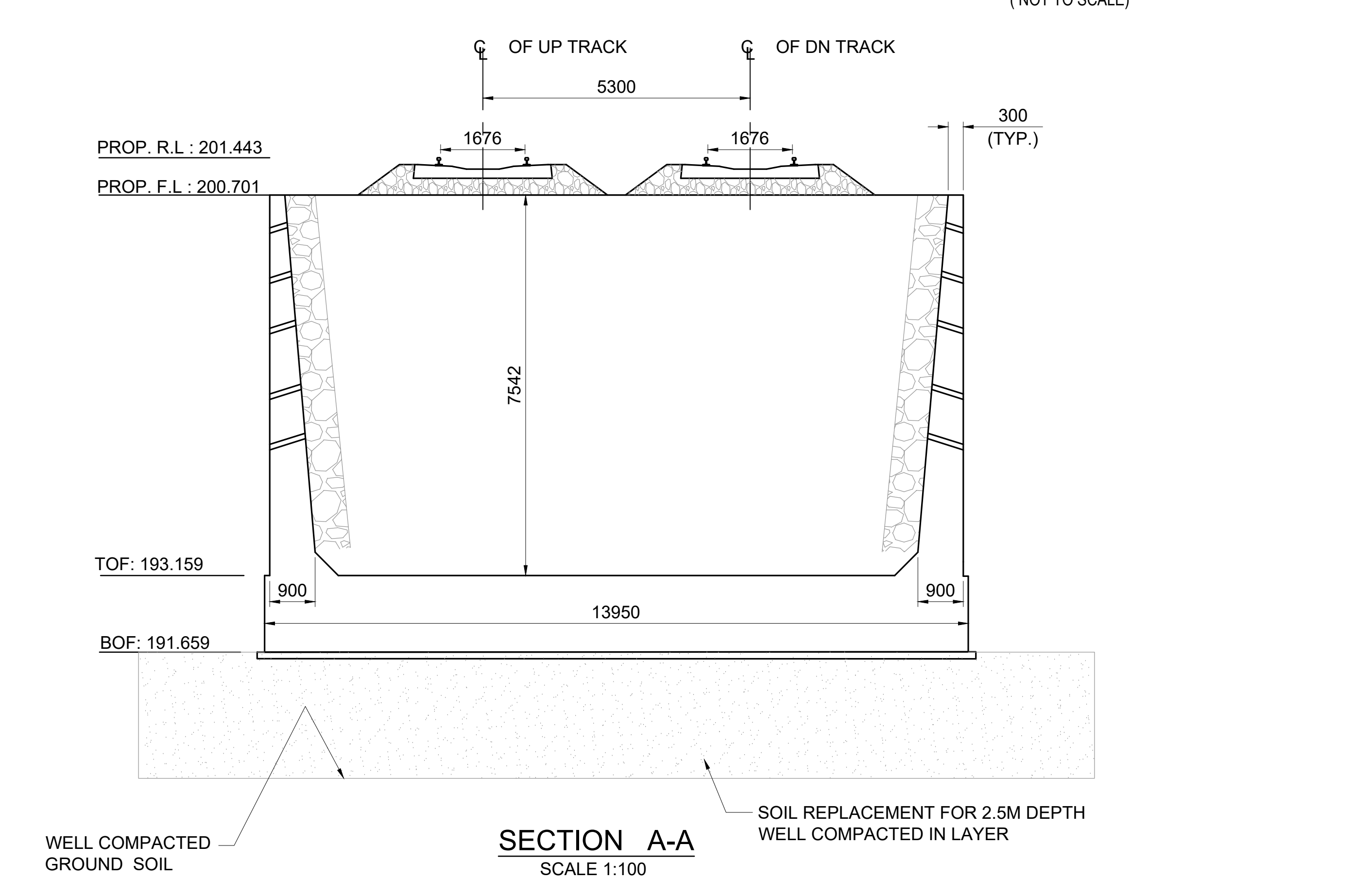
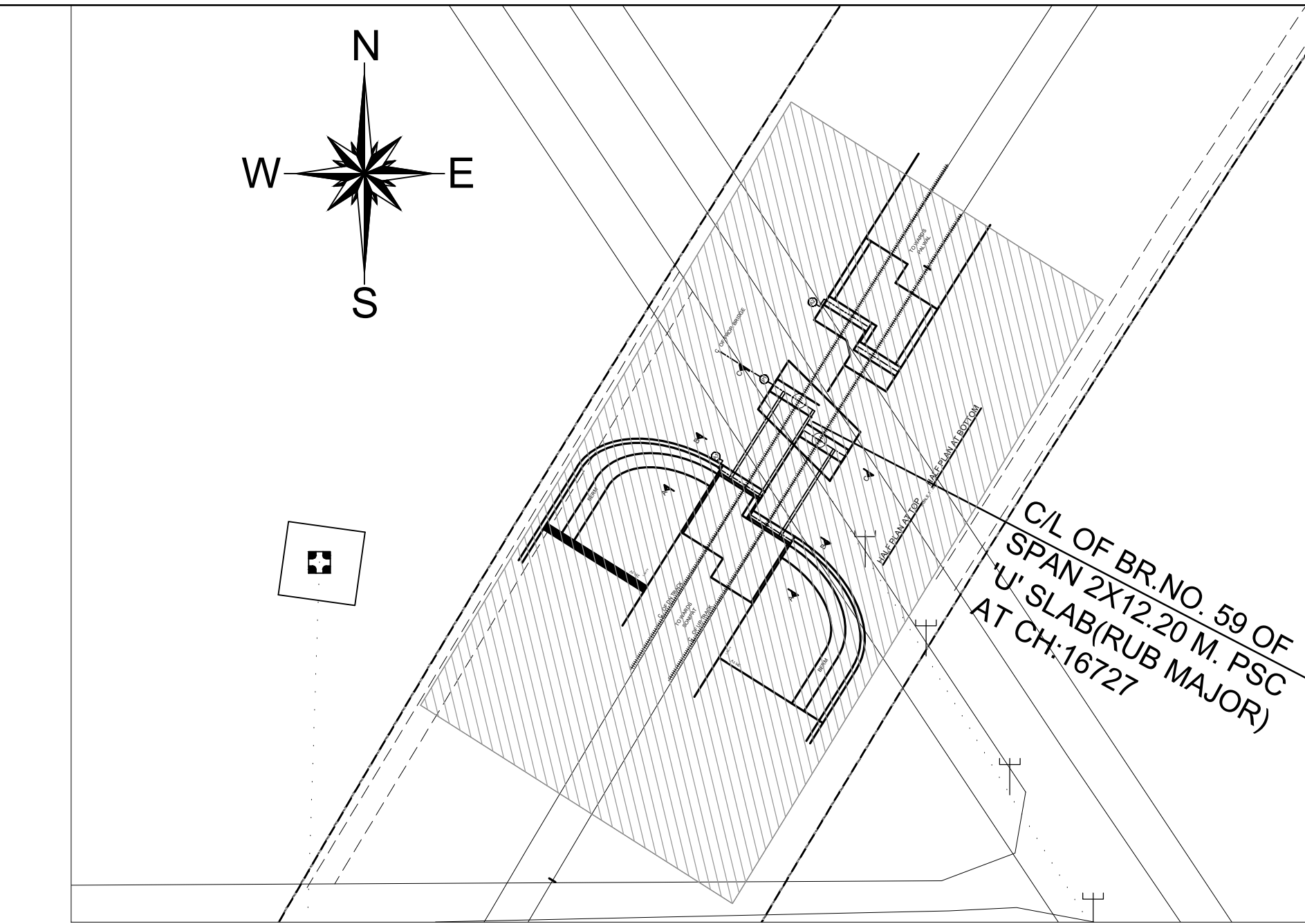
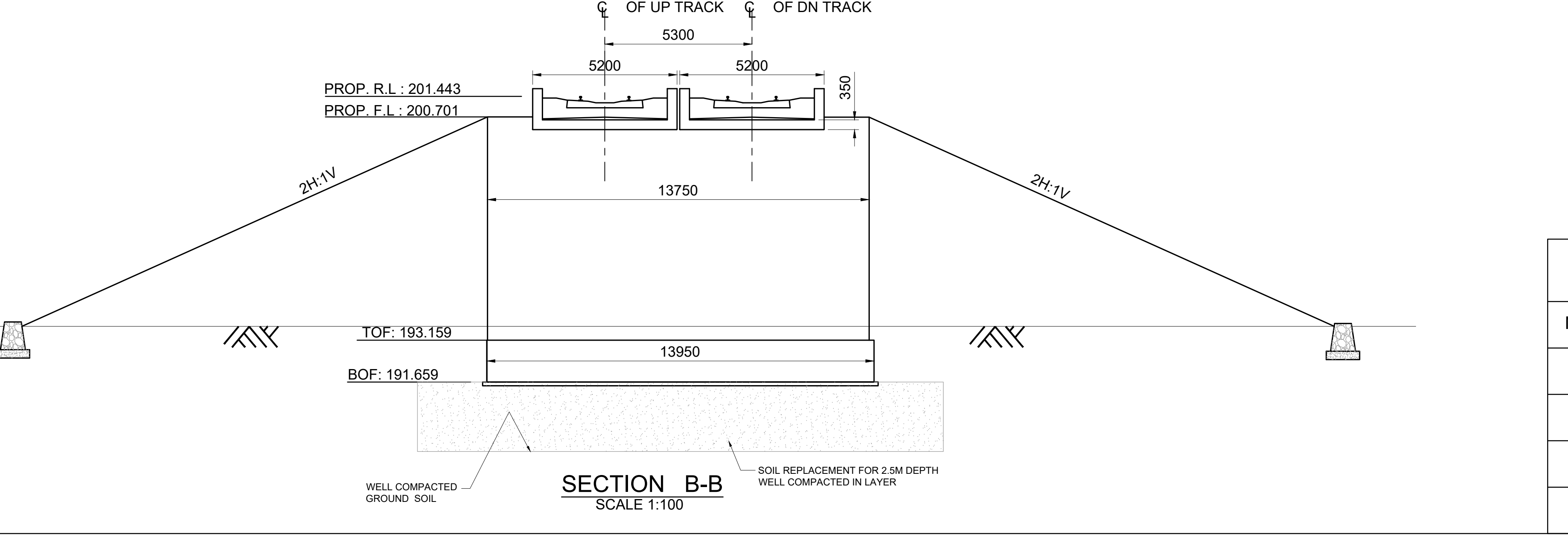
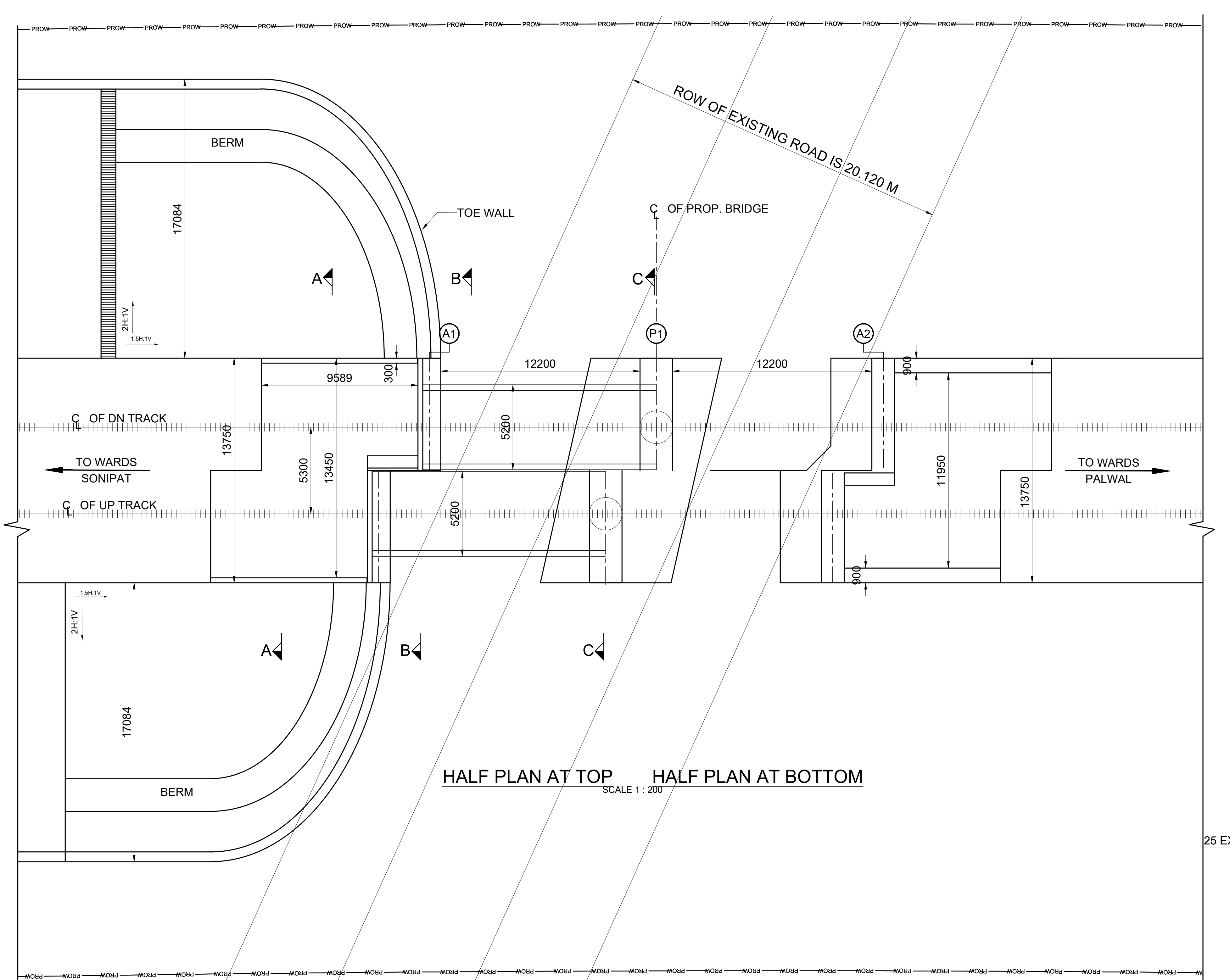
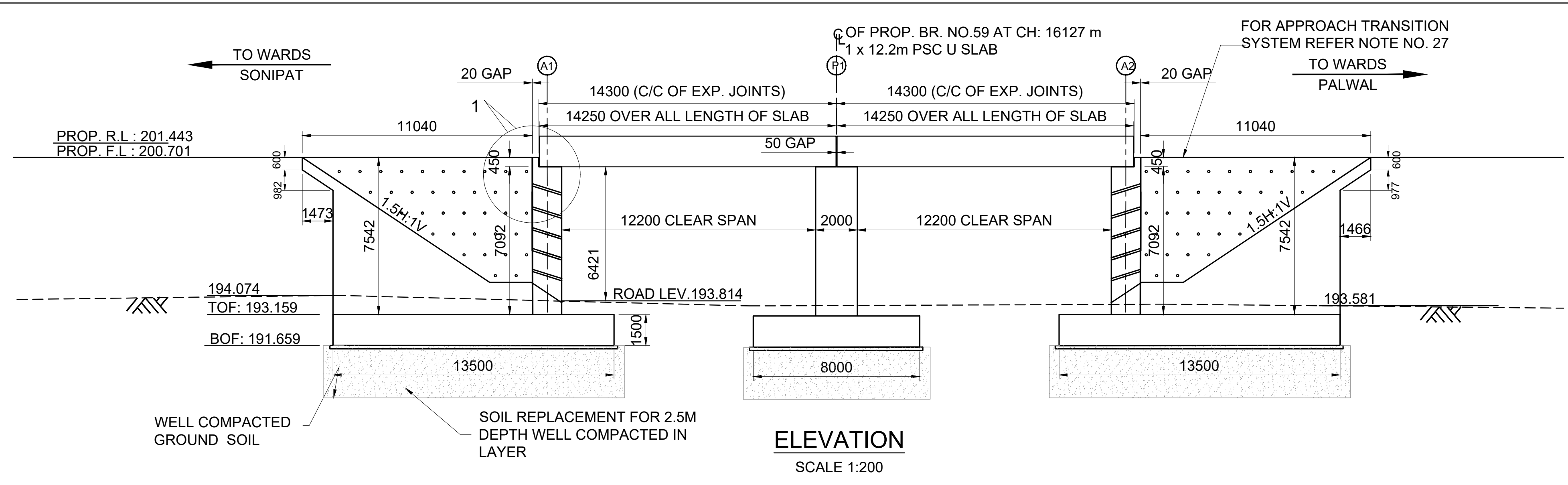

- NOTES:**
- ALL DIMENSIONS ARE IN MILLIMETERS AND LEVELS ARE IN METER DIMENSIONS ARE NOT TO BE SCALED ONLY WRITTEN DIMENSIONS TO BE FOLLOWED
 - DESIGN CRITERIA
 - IRS BRIDGE SUBSTRUCTURE AND FOUNDATION CODE 2013.
 - IRS CONCRETE BRIDGE CODE 2014.
 - IRS BRIDGE RULES 2014.
 - IS 2911 PART-1 SECTION-2.
 - EXPOSURE CONDITION - MODERATE.
 - SEISMIC ZONE - IV
 - STANDARD OF LOADING - SUPER STRUCTURE-25T (RDSO STANDARD) & SUB STRUCTURE-32.5T-2008 LOADING.
 - THE STRUCTURAL DIMENSIONS AND SIZES ARE INDICATIVE AND THESE MAY VARY DURING DETAIL DESIGN.
 - SIZE & TYPE OF FOUNDATION SHOWN IS TENTATIVE AND MAY CHANGE DURING DETAILED DESIGN.
 - ALL RCC AND CC WORKS SHALL BE DONE IN ACCORDANCE WITH SPECIFICATION LAID DOWN IN IRS CONCRETE BRIDGE CODE. THE GRADE OF CONCRETE
 - FOR ABUTMENT, DIRT & RETURN WALL-----M35
 - FOR FOUNDATION-----M30
 - FOR LEVELING COURSE-----M20
 - ALL CONCRETE WORK SHALL BE MECHANICALLY MIXED AND VIBRATED. MIX DESIGN SHALL BE APPROVED BY ENGINEER - IN CHARGE.
 - HIGH YIELD STRENGTH DEFORMED BARS OF GRADE Fe-500D CONFORMING TO IS: 1786-2008 SHALL BE USED AS REINFORCEMENT.
 - BED LEVEL & ROAD LEVEL, FORMATION LEVEL AND RAIL LEVEL & ALIGNMENT SHALL BE VERIFIED BY THE ENGINEER AT SITE BEFORE EXECUTION OF WORK.
 - ANGLE OF INTERNAL FRICTION OF BACK FILL SHALL NOT BE LESS THAN 35.
 - PROTECTION WORK ON SLOPES OF BANK UP TO 30M, BOTH SIDES ON APPROACHES OF BRIDGE SHALL BE DONE AS PER SKETCH NO. GC-HRIDC-SK-GEN-015.
 - BOULDER FILLING & BOULDER PACKING BEHIND RETURN WALL/WING WALL TO BE DONE AS PER IRS FOUNDATION & SUBSTRUCTURE CODE CL.7.5.2.
 - BACK FILL BEHIND RETURN WALL/WING WALL SHALL BE AS PER CL.7.5 OF IRS BRIDGE SUBSTRUCTURE & FOUNDATION CODE 2013.
 - 75mm DIA WEEP HOLES TO BE PROVIDED @1000 C/C HORZ. AND 1000 MM C/C VERTICALLY ABOVE LOWEST WATER LEVEL IN RETURN WALL AS PER IRS SUB STRUCTURE CODE CLAUSE 7.6.
 - ALL RCC SURFACES COMING IN CONTACT WITH SOIL SHOULD BE PAINTED WITH BITUMEN OR COAL TAR OF APPROVED QUALITY @ 1.464 KG/SQM CONFORMING TO IS-3117.
 - CURING SHALL BE DONE AS PER CLAUSE NO.8.4 OF IRS CONCRETE BRIDGE CODE.
 - SAFETY & PROTECTION OF THE PROPOSED WORK IS TO BE ENSURED BY THE CONTRACTOR AS PER PARA 826 OF IRPVM WITH UPDATED CORRECTION SLIPS OF 2011-12.
 - THE SPECIFICATIONS FOR THE PSC U SLAB SHALL BE IN ACCORDANCE WITH RDSO DRG.NO'S : RDSO 10281,10281/1 AND 10281/2.
 - CONCRETING SHALL BE DONE IN ACCORDANCE WITH IRS CONCRETE BRIDGE CODE WITH 20MM MAXIMUM SIZE AGGREGATE.
 - ALL DIMENSIONS AND LEVELS SHOULD BE VERIFIED AT SITE BEFORE EXECUTION.
 - BRIDGE DETAILS LIKE , DL, INSPECTION STEPS PAINTINGS ETC SHOULD BE FOLLOWED AS PER BRIDGE MANUAL DURING CONSTRUCTION.
 - THIS DRAWING IS PROPERTY OF HARYANA RAIL INFRASTRUCTURE DEVELOPMENT CORPORATION LIMITED (HRIDC) AND EXCLUSIVE USE OF HRIDC.
 - FOR TOE WALL DETAILS REFER SEPARATE SKETCH NO. GC-HRIDC-SK-GEN-014.
 - BEARING CAPACITY OF SOIL SHALL BE ENSURED AS PER DETAILED DESIGN REQUIREMENT. GROUND IMPROVEMENT SHALL BE CARRIED OUT AS PER GT REPORT AND CONFIRMED THROUGH FIELD TESTING.
 - TRANSITION SYSTEM TO BE ADOPTED ON BRIDGE APPROACHES SHALL BE AS PER RDSO REPORT NO. GE-R-50(TRANSITION SYSTEM ON APPROACHES OF BRIDGES). FOR DETAILS REFER SKETCH NO. GC-HRIDC-SK-GEN-019.

LEGEND

PRL	PROPOSED RAIL LEVEL
PFL	PROPOSED FORMATION LEVEL
HFL	HIGHEST FLOOD LEVEL
GL	GROUND LEVEL
TOF	TOP OF FOUNDATION
BOF	BOTTOM OF FOUNDATION

PROJECT:
HARYANA ORBITAL RAIL CORRIDOR
CONNECTING PALWAL TO SONIPAT BYPASSING DELHI AREA BY LINKING ASAOTI-PATLI-SULTANPUR-ASAUDAH BY NEW ELECTRIFIED BG DOUBLE LINE

CLIENT:
 HARYANA RAIL INFRASTRUCTURE DEVELOPMENT CORPORATION LIMITED.

CONSULTANT:
 GENERAL CONSULTANT FOR HARYANA ORBITAL RAIL CORRIDOR
RITES Limited in consortium with SMEC International Pty. Ltd.

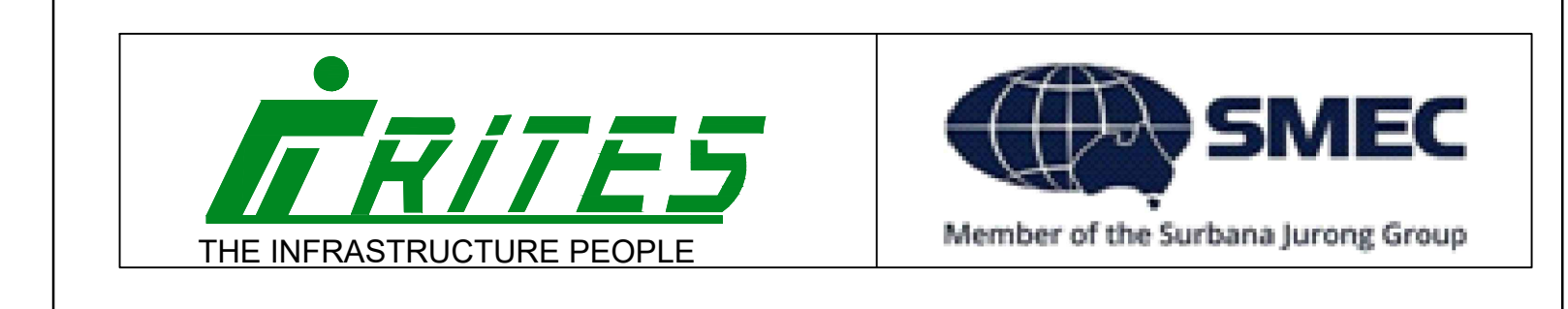

TITLE:- CONCEPTUAL GENERAL ARRANGEMENT DRAWING
PROPOSED RUB NO. 059
2 x 12.2m PSC U SLAB CH: 16727

DRG. NO. GC-HRIDC-C4-DRW-BRD-GAD-01059_A2
SHEET NO. 1 OF 1

SCALE : AS SHOWN
ISSUE DATE 07-11-2022
REVISED DATE 10-01-2023

GC/HORC		HRIDC	
NAME / DESIGNATION	SIGN	NAME / DESIGNATION	SIGN
CHAHATEY RAM PD		SHIV OM DWIVEDI CPM/HRIDC	
SUDHIR AGRAWAL DPD/CIVIL		RAJU SOLANKI DGM/CIVIL/SOUTH	
REETU PATIAL CDE/ CIVIL			

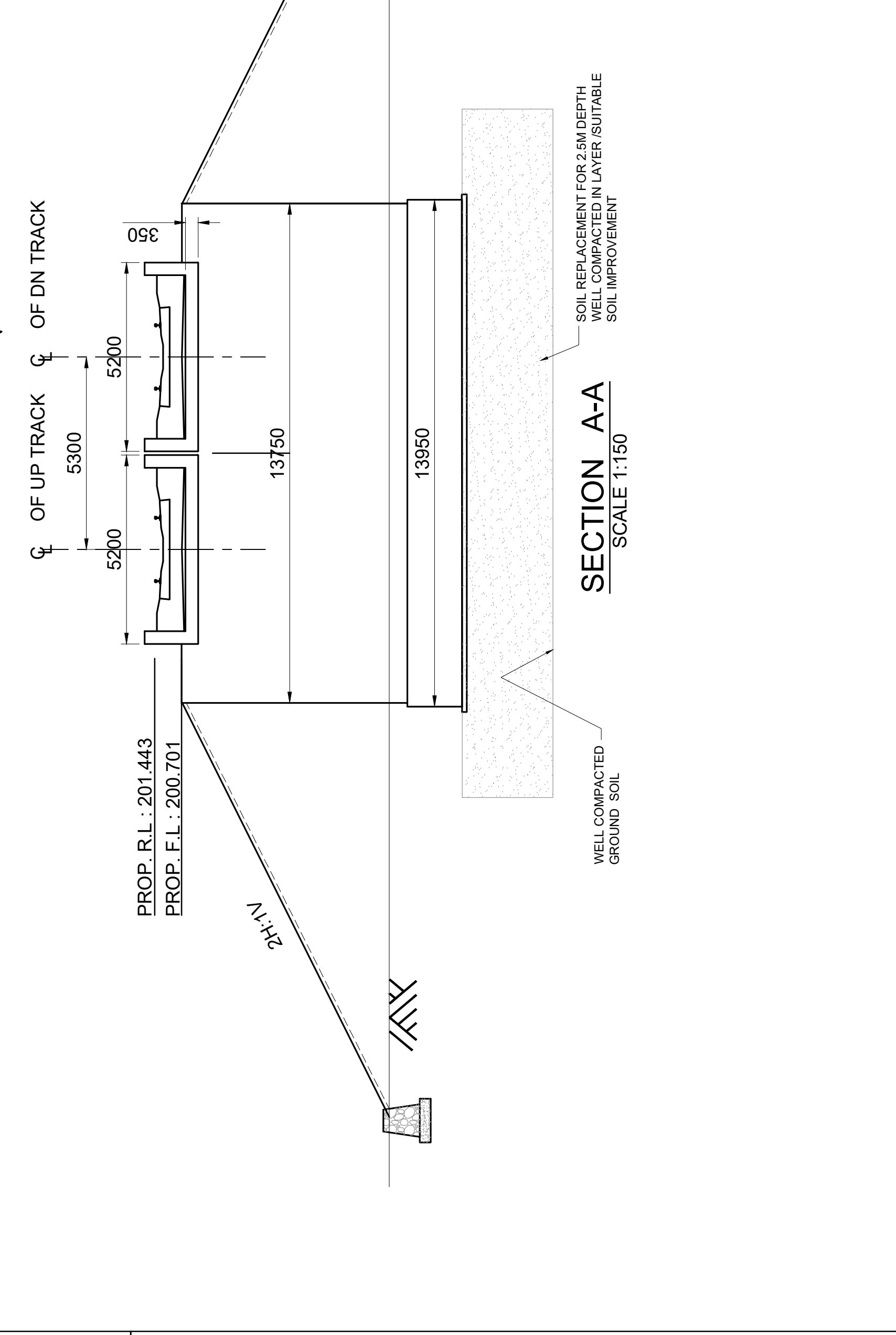
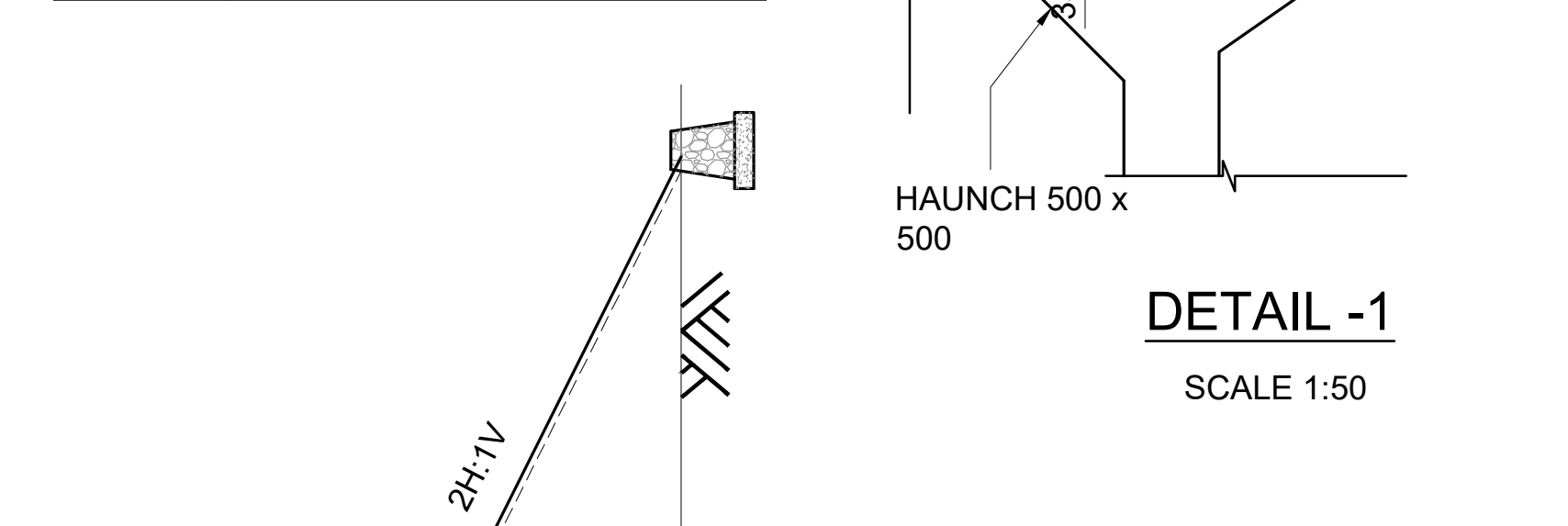
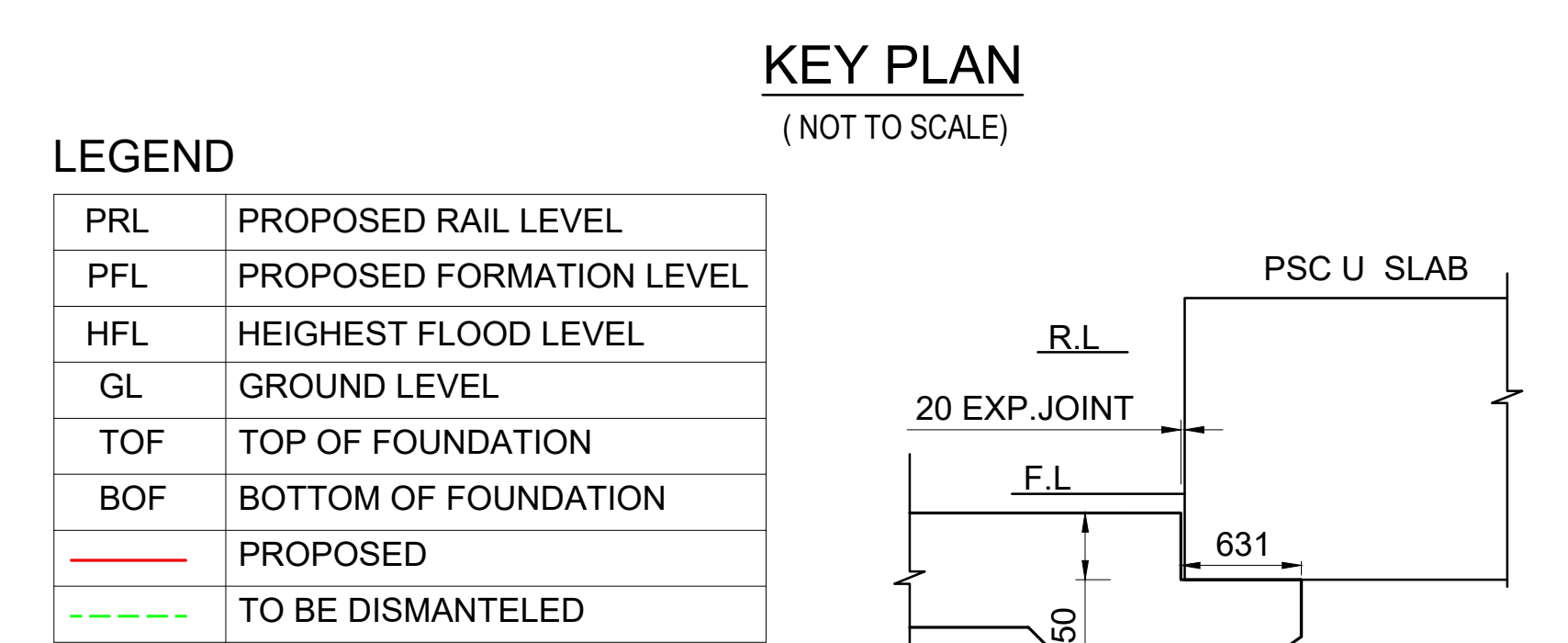
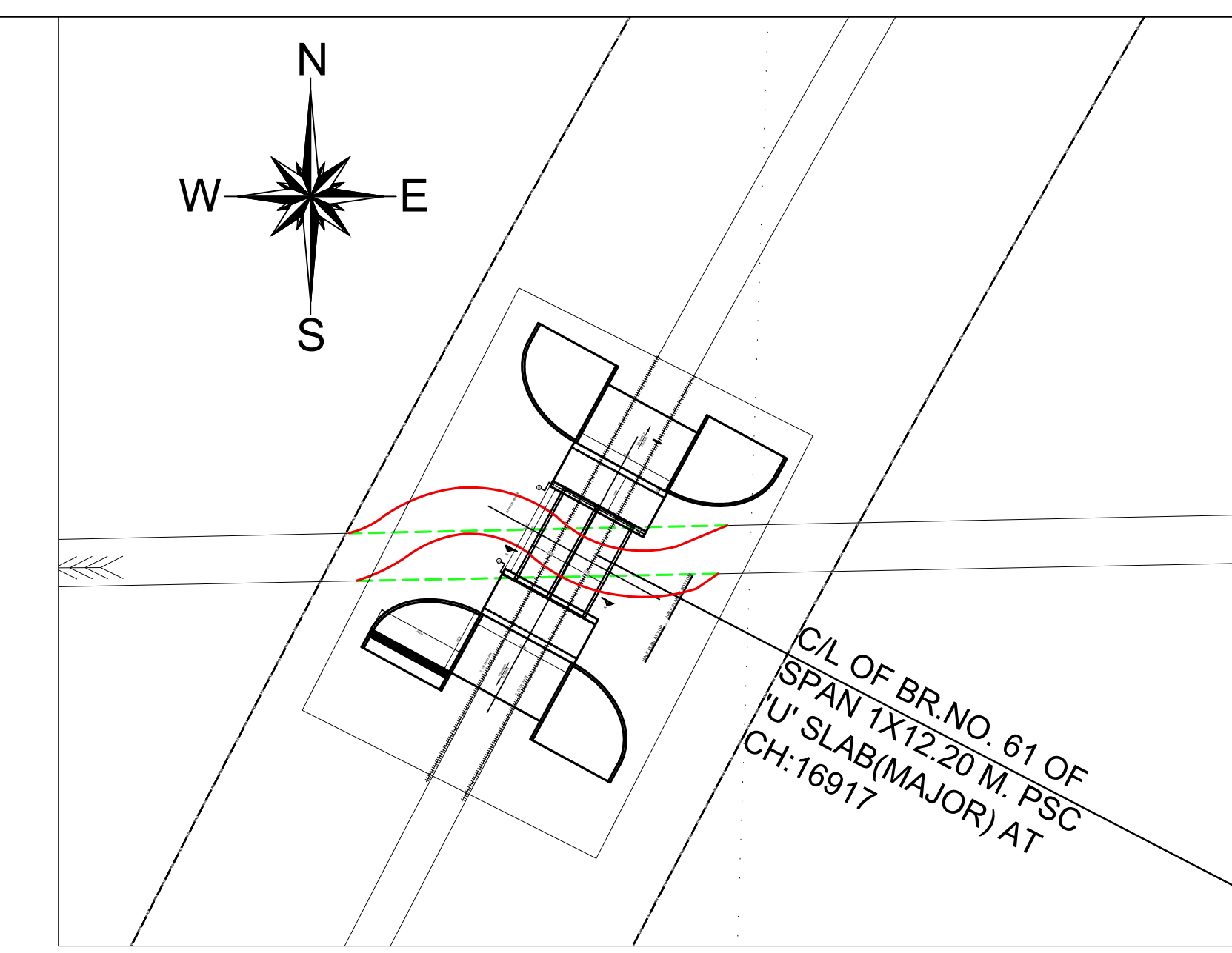
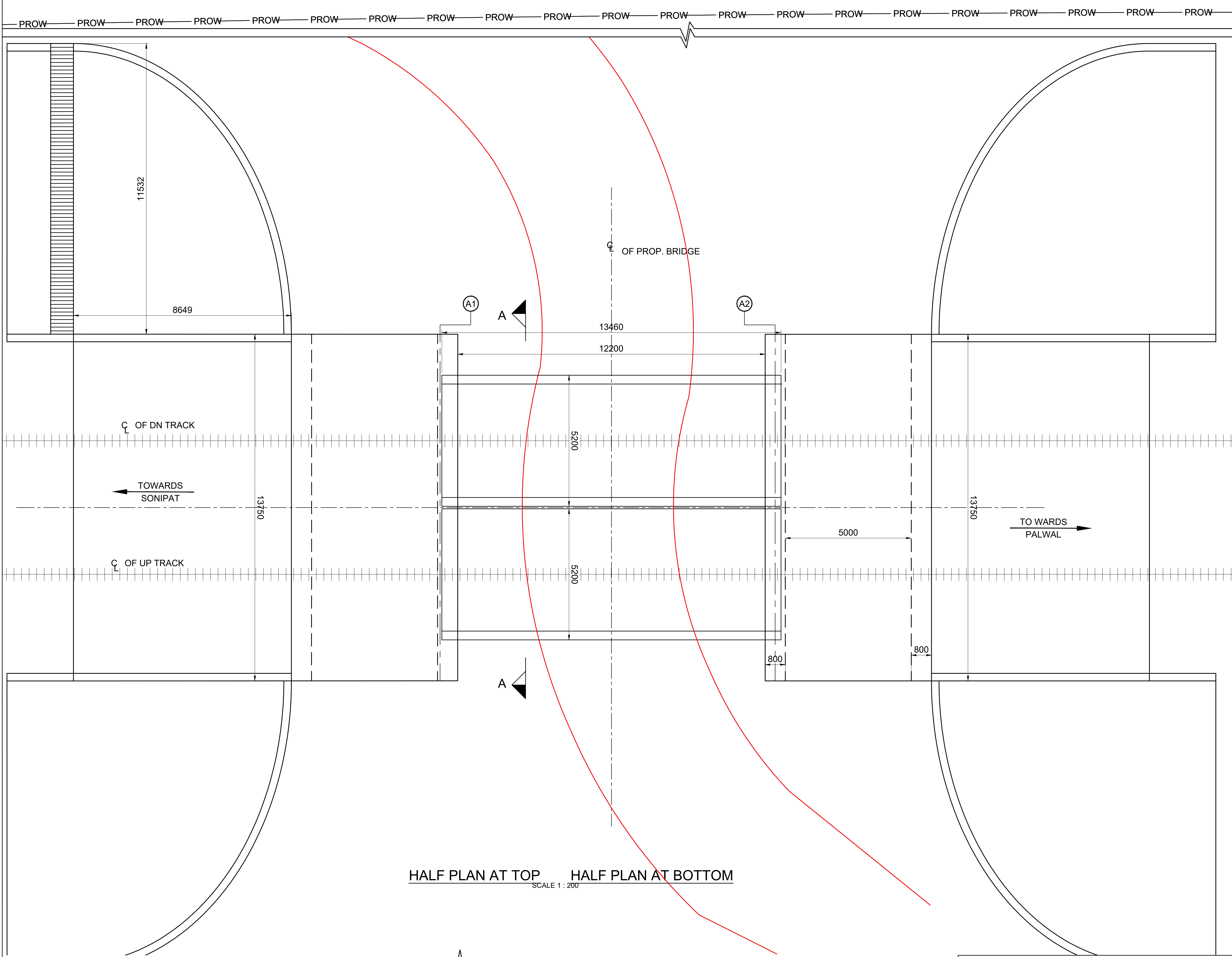
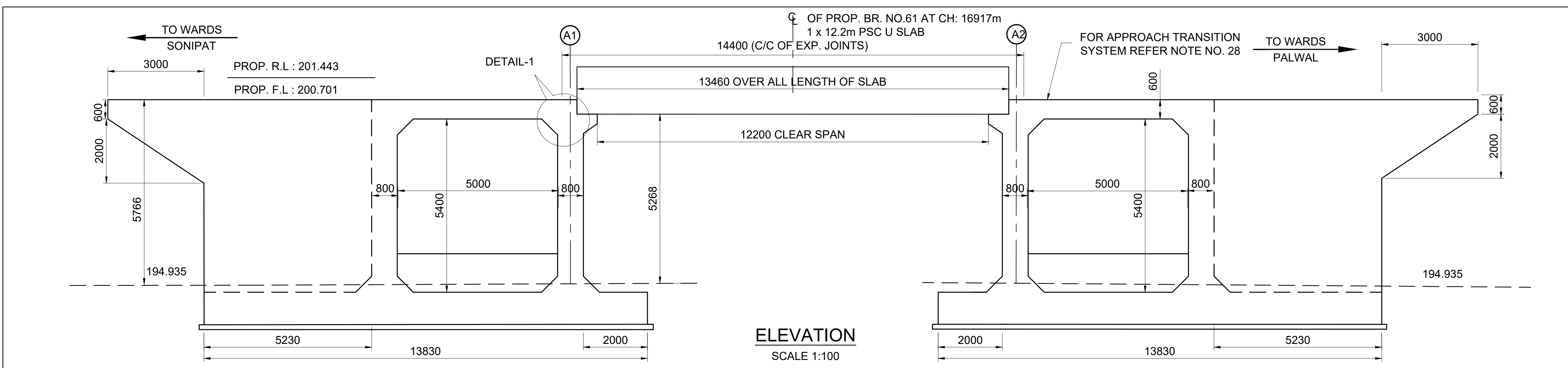

- NOTES:**
- ALL DIMENSIONS ARE IN MILLIMETERS AND LEVELS ARE IN METER DIMENSIONS ARE NOT TO BE SCALED ONLY WRITTEN DIMENSIONS TO BE FOLLOWED
 - DESIGN CRITERIA
 - IRS BRIDGE SUBSTRUCTURE AND FOUNDATION CODE 2013.
 - IRS CONCRETE BRIDGE CODE 2014.
 - IRS BRIDGE RULES 2014.
 - IS 2911 PART-1 SECTION-2.
 - EXPOSURE CONDITION - MODERATE.
 - SEISMIC ZONE - IV
 - STANDARD OF LOADING - SUPER STRUCTURE-25T (RDSO STANDARD) & SUB STRUCTURE-32.5T-2008 LOADING.
 - THE STRUCTURAL DIMENSIONS AND SIZES ARE INDICATIVE AND THESE MAY VARY DURING DETAIL DESIGN.
 - ALL RCC AND CC WORKS SHALL BE DONE IN ACCORDANCE WITH SPECIFICATION LAID DOWN IN IRS CONCRETE BRIDGE CODE.
 - THE GRADE OF CONCRETE
 - FOR ABUTMENT, DIRT & RETURN WALL-----M35
 - FOR FOUNDATION-----M30
 - FOR LEVELING COURSE-----M20
 - ALL CONCRETE WORK SHALL BE MECHANICALLY MIXED AND VIBRATED.
 - MIX DESIGN SHALL BE APPROVED BY ENGINEER - IN CHARGE.
 - HIGH YIELD STRENGTH DEFORMED BARS OF GRADE Fe-500D CONFORMING TO IS: 1786-2008 SHALL BE USED AS REINFORCEMENT.
 - BED LEVEL & ROAD LEVEL, FORMATION LEVEL AND RAIL LEVEL & ALIGNMENT SHALL BE VERIFIED BY THE ENGINEER AT SITE BEFORE EXECUTION OF WORK.
 - ANGLE OF INTERNAL FRICTION OF BACK FILL SHALL NOT BE LESS THAN 35.
 - PROTECTION WORK ON SLOPES OF BANK UP TO 30M, BOTH SIDES ON APPROACHES OF BRIDGE SHALL BE DONE AS PER SKETCH NO. GC-HRIDC-SK-GEN-015.
 - BOULDER FILLING & BOULDER PACKING BEHIND RETURN WALL/WING WALL TO BE DONE AS PER IRS FOUNDATION & SUBSTRUCTURE CODE CL.7.5.2.
 - BACK FILL BEHIND RETURN WALL/WING WALL SHALL BE AS PER CL.7.5 OF IRS BRIDGE SUBSTRUCTURE & FOUNDATION CODE 2013.
 - 75mm DIA WEEP HOLES TO BE PROVIDED @1000 C/C HORZ. AND 1000 MM C/C VERTICALLY ABOVE LOWEST WATER LEVEL IN RETURN WALL AS PER IRS SUB STRUCTURE CODE CLAUSE 7.6.
 - ALL RCC SURFACES COMING IN CONTACT WITH SOIL SHOULD BE PAINTED WITH BITUMEN OR COAL TAR OF APPROVED QUALITY @ 1.464 KG/SQM CONFORMING TO IS-3117.
 - CURING SHALL BE DONE AS PER CLAUSE NO 8.4 OF IRS CONCRETE BRIDGE CODE.
 - SAFETY & PROTECTION OF THE PROPOSED WORK IS TO BE ENSURED BY THE CONTRACTOR AS PER PARA 826 OF IRPMM WITH UPDATED CORRECTION SLIPS OF 2011-12.
 - THE SPECIFICATIONS FOR THE PSC U SLAB SHALL BE IN ACCORDANCE WITH RDSO DRG.NO'S : RDSO 10281, 10281/1 AND 10281/2.
 - CONCRETING SHALL BE DONE IN ACCORDANCE WITH IRS CONCRETE BRIDGE CODE WITH 20MM MAXIMUM SIZE AGGREGATE.
 - ALL DIMENSIONS AND LEVELS SHOULD BE VERIFIED AT SITE BEFORE EXECUTION.
 - BRIDGE DETAILS LIKE , DL, INSPECTION STEPS PAINTINGS ETC SHOULD BE FOLLOWED AS PER BRIDGE MANUAL DURING CONSTRUCTION.
 - THIS DRAWING IS PROPERTY OF HARYANA RAIL INFRASTRUCTURE DEVELOPMENT CORPORATION LIMITED (HRIDC) AND EXCLUSIVE USE OF HRIDC.
 - FOR TOE WALL DETAILS REFER SEPARATE SKETCH NO. GC-HRIDC-SK-GEN-014.
 - BEARING CAPACITY OF SOIL SHALL BE ENSURED AS PER DETAILED DESIGN REQUIREMENT. SUITABLE GROUND IMPROVEMENT SHALL BE CARRIED OUT AS PER GT & DESIGN REQUIREMENT AND CONFIRMED THROUGH FIELD TESTING.
 - SMOOTH TRANSITION SHALL BE PROVIDED BETWEEN THE EXISTING LINED CANAL/DRAIN AND THE BOX.
 - TRANSITION SYSTEM TO BE ADOPTED ON BRIDGE APPROACHES SHALL BE AS PER RDSO REPORT NO. GE-R-50 (TRANSITION SYSTEM ON APPROACHES OF BRIDGES). FOR DETAILS REFER SKETCH NO. GC-HRIDC-SK-GEN-019.

PROJECT:
HARYANA ORBITAL RAIL CORRIDOR
 CONNECTING PALWAL TO SONIPAT BYPASSING DELHI AREA BY LINKING ASAOTI-PATLI-SULTANPUR-ASAUDAH BY NEW ELECTRIFIED BG DOUBLE LINE

CLIENT:
HARYANA RAIL INFRASTRUCTURE DEVELOPMENT CORPORATION LIMITED.

CONSULTANT:
GENERAL CONSULTANT FOR HARYANA ORBITAL RAIL CORRIDOR
 RITES Limited in consortium with SMEC International Pty. Ltd.

IRITES THE INFRASTRUCTURE PEOPLE **SMEC** Member of the Surbana Jurong Group

TITLE:- **CONCEPTUAL GENERAL ARRANGEMENT DRAWING**
 PROPOSED CANAL BR. NO. 061
 1x5.4+1x12.2+1x5.5.4m PSC U SLAB CH: 16917

DRG. NO. GC-HRIDC-C4-DRW-BRD-GAD-01061_A2 **SHEET NO.** 1 OF 1

SCALE : AS SHOWN **ISSUE DATE** 07-11-2022 **REVISED DATE** 10-01-2023

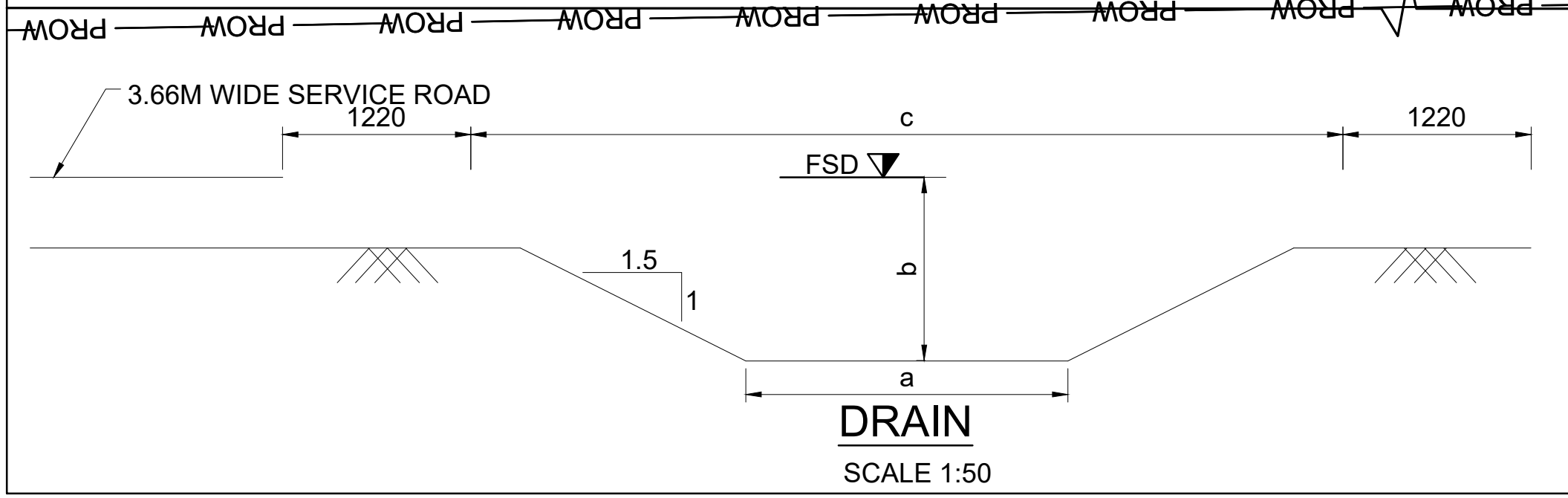

HYDRAULIC DATA OF DRAIN

1	NAME OF MINOR	BHIRAOTI MINOR
2	RD	6050/16917
3	FREE BOARD	0.45
4	DISCHARGE	45.02Cusec
5	BED WIDTH	a 2.088
6	F.S.D	b 1.19
7	SIDE SLOPE	1.5:1
8	TOP WIDTH	c 5.65
9	SHAPE	

GC/HORC

NAME / DESIGNATION	SIGN
CHAHATEY RAM PD	<i>ChahateyRam</i>
SUDHIR AGRAWAL DPD/CIVIL	<i>MS</i>
REETU PATIAL CDE/ CIVIL	<i>RE</i>

HRIDC

NAME / DESIGNATION	SIGN
SHIV OM DWIVEDI CPM/HRIDC	<i>Shiv</i>
RAJU SOLANKI DGM/CIVIL/SOUTH	<i>Raju</i>

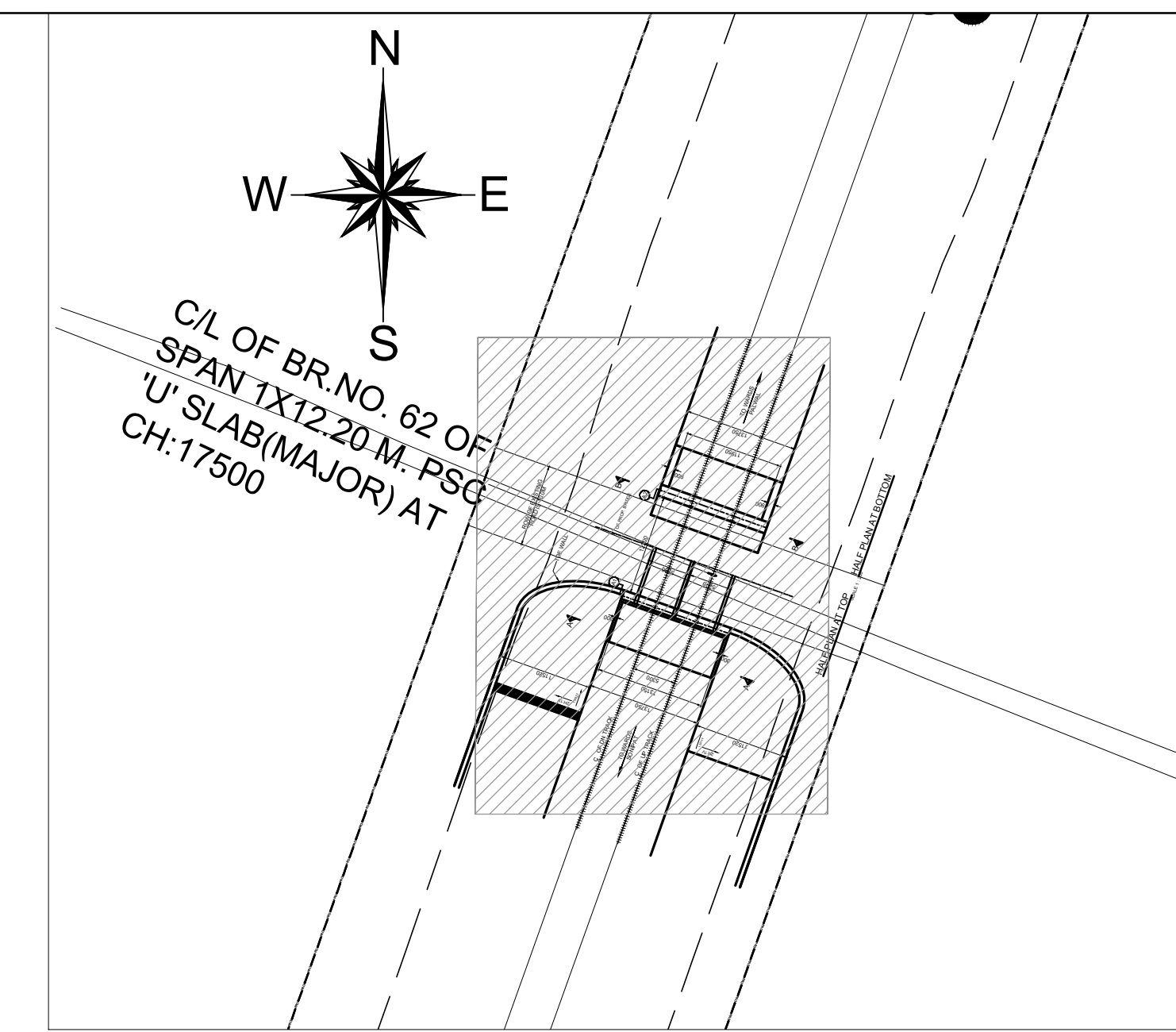
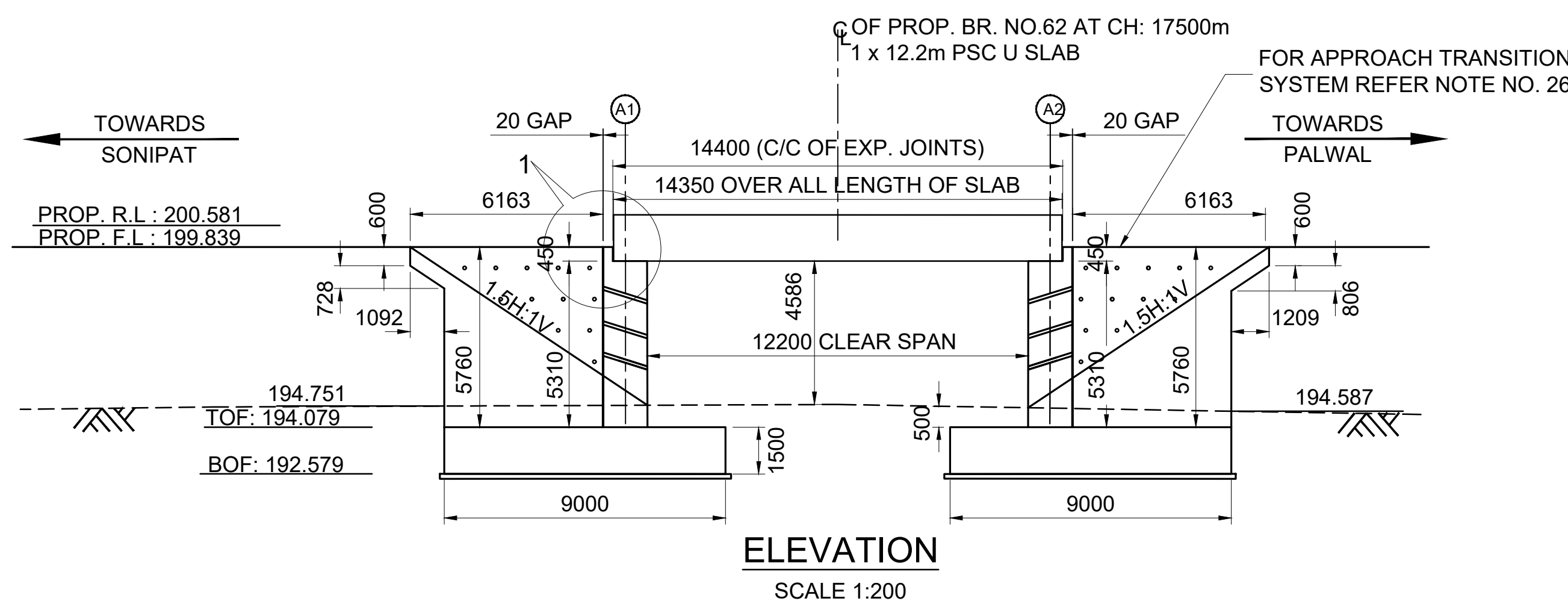

- NOTES:**
- ALL DIMENSIONS ARE IN MILLIMETERS AND LEVELS ARE IN METER. DIMENSIONS ARE NOT TO BE SCALED ONLY WRITTEN DIMENSIONS TO BE FOLLOWED.
 - DESIGN CRITERIA
 - IRS BRIDGE SUBSTRUCTURE AND FOUNDATION CODE 2013.
 - IRS CONCRETE BRIDGE CODE 2014.
 - IRS BRIDGE RULES 2014.
 - IS 2911 PART-1 SECTION-2.
 - EXPOSURE CONDITION - MODERATE.
 - SEISMIC ZONE - IV
 - STANDARD OF LOADING - SUPER STRUCTURE-25T (RDSO STANDARD) & SUB STRUCTURE-32.5T - 2008. LOADING.
 - THE STRUCTURAL DIMENSIONS AND SIZES ARE INDICATIVE AND THESE MAY VARY DURING DETAIL DESIGN.
 - SIZE & TYPE OF FOUNDATION SHOWN IS TENTATIVE AND MAY CHANGE DURING DETAILED DESIGN.
 - ALL RCC AND CC WORKS SHALL BE DONE IN ACCORDANCE WITH SPECIFICATION LAID DOWN IN IRS CONCRETE BRIDGE CODE. THE GRADE OF CONCRETE
 - FOR ABUTMENT, DIRT & RETURN WALL - M35
 - FOR FOUNDATION - M30
 - FOR LEVELING COURSE - M20
 - ALL CONCRETE WORK SHALL BE MECHANICALLY MIXED AND VIBRATED. MIX DESIGN SHALL BE APPROVED BY ENGINEER - IN CHARGE.
 - HIGH YIELD STRENGTH DEFORMED BARS OF GRADE Fe-500D CONFORMING TO IS: 1786-2008 SHALL BE USED AS REINFORCEMENT.
 - BED LEVEL & ROAD LEVEL, FORMATION LEVEL AND RAIL LEVEL & ALIGNMENT SHALL BE VERIFIED BY THE ENGINEER AT SITE BEFORE EXECUTION OF WORK.
 - ANGLE OF INTERNAL FRICTION OF BACK FILL SHALL NOT BE LESS THAN 35.
 - PROTECTION WORK ON SLOPES OF BANK UP TO 30M, BOTH SIDES ON APPROACHES OF BRIDGE SHALL BE DONE AS PER SKETCH NO. GC-HRIDC-SK-GEN-015.
 - BOULDER FILLING & BOULDER PACKING BEHIND RETURN WALL/WING WALL TO BE DONE AS PER IRS FOUNDATION & SUBSTRUCTURE CODE CL.7.5.2.
 - BACK FILL BEHIND RETURN WALL/WING WALL SHALL BE AS PER CL.7.5 OF IRS BRIDGE SUBSTRUCTURE & FOUNDATION CODE 2013.
 - 75mm DIA WEEP HOLES TO BE PROVIDED @1000 C/C HORZ. AND 1000 MM C/C VERTICALLY ABOVE LOWEST WATER LEVEL IN RETURN WALL AS PER IRS SUB STRUCTURE CODE CLAUSE 7.6.
 - ALL RCC SURFACES COMING IN CONTACT WITH SOIL SHOULD BE PAINTED WITH BITUMEN OR COAL TAR OF APPROVED QUALITY @ 1.464KG/SQM. CONFORMING TO IS-3117.
 - CURING SHALL BE DONE AS PER CLAUSE NO 8.4 OF IRS CONCRETE BRIDGE CODE.
 - SAFETY & PROTECTION OF THE PROPOSED WORK IS TO BE ENSURED BY THE CONTRACTOR AS PER PARA 826 OF IRPMM WITH UPDATED CORRECTION SLIPS OF 2011-12.
 - THE SPECIFICATIONS FOR THE PSC U SLAB SHALL BE IN ACCORDANCE WITH RDSO DRG. NO'S : RDSO 10281.10281/1 AND 10281/2.
 - CONCRETING SHALL BE DONE IN ACCORDANCE WITH IRS CONCRETE BRIDGE CODE WITH 20MM MAXIMUM SIZE AGGREGATE.
 - ALL DIMENSIONS AND LEVELS SHOULD BE VERIFIED AT SITE BEFORE EXECUTION.
 - BRIDGE DETAILS LIKE , DL, INSPECTION STEPS PAINTINGS ETC SHOULD BE FOLLOWED AS PER BRIDGE MANUAL DURING CONSTRUCTION.
 - THIS DRAWING IS PROPERTY OF HARYANA RAIL INFRASTRUCTURE DEVELOPMENT CORPORATION LIMITED (HRIDC) AND EXCLUSIVE USE OF HRIDC.
 - FOR TOE WALL DETAILS REFER SEPARATE SKETCH NO. GC-HRIDC-SK-GEN-014.
 - TRANSITION SYSTEM TO BE ADOPTED ON BRIDGE APPROACHES SHALL BE AS PER RDSO REPORT NO. GE-R-50(TRANSITION SYSTEM ON APPROACHES OF BRIDGES). FOR DETAILS REFER SKETCH NO. GC-HRIDC-SK-GEN-019.

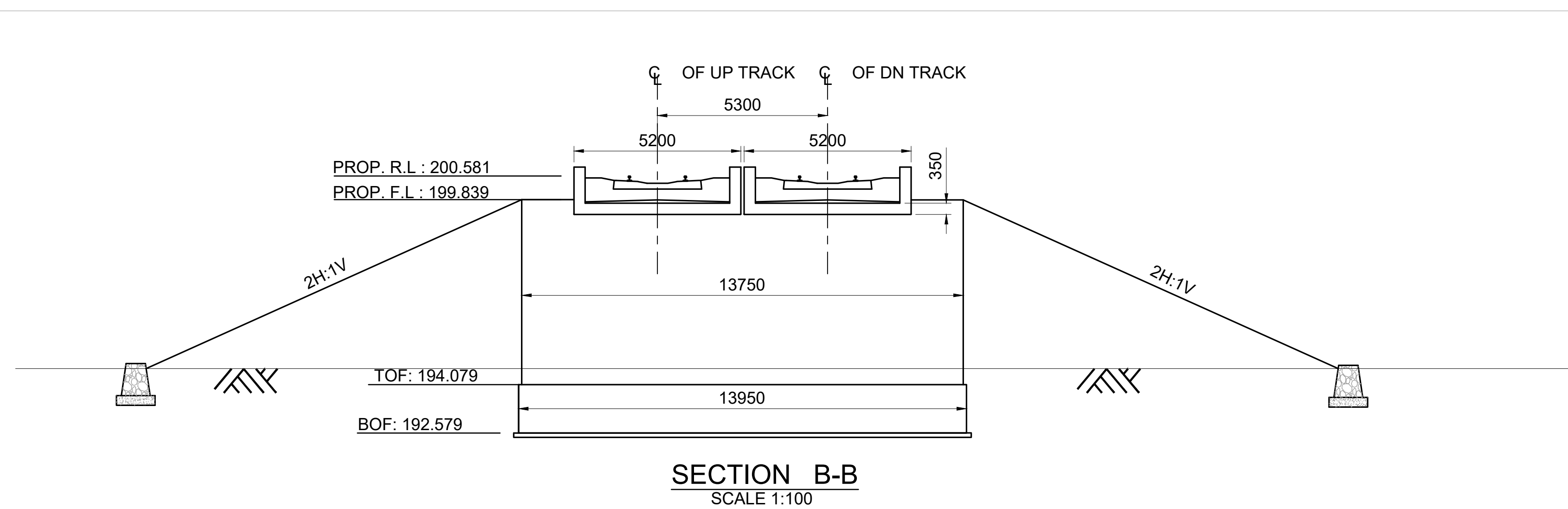
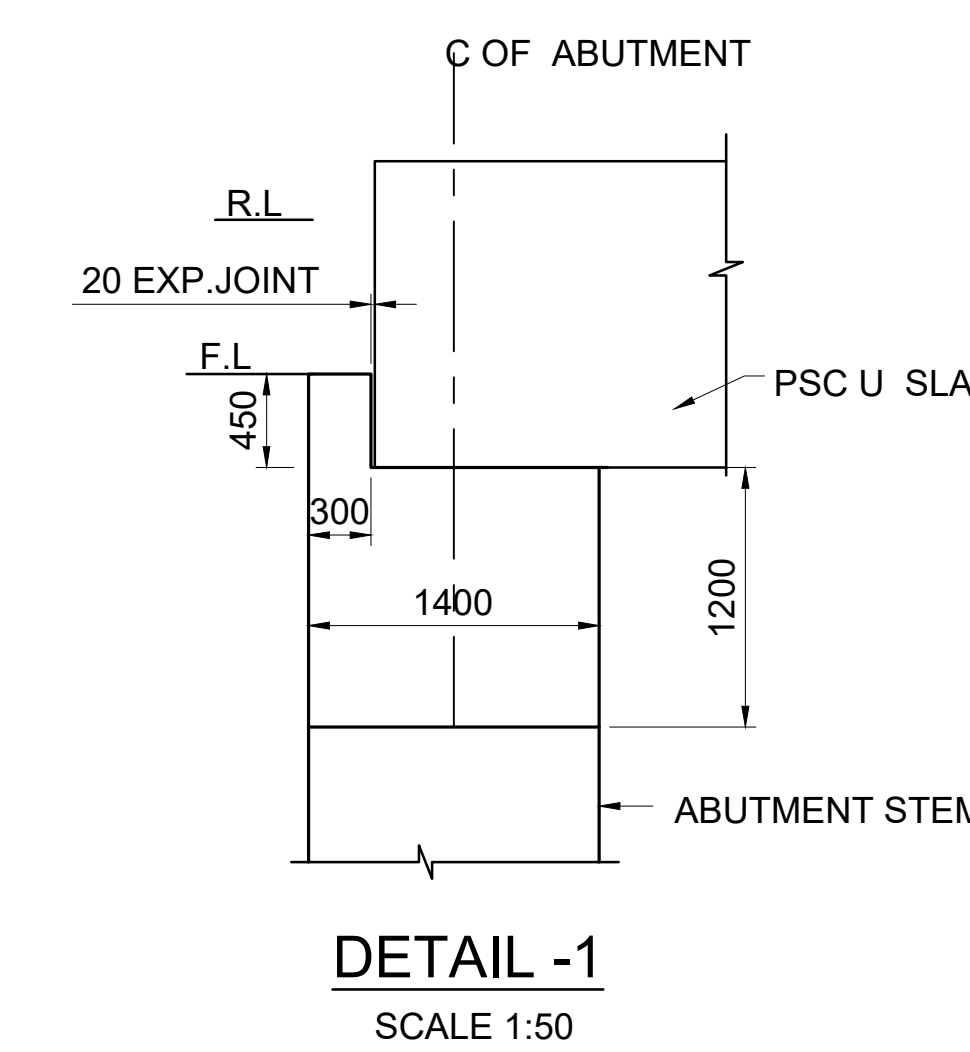
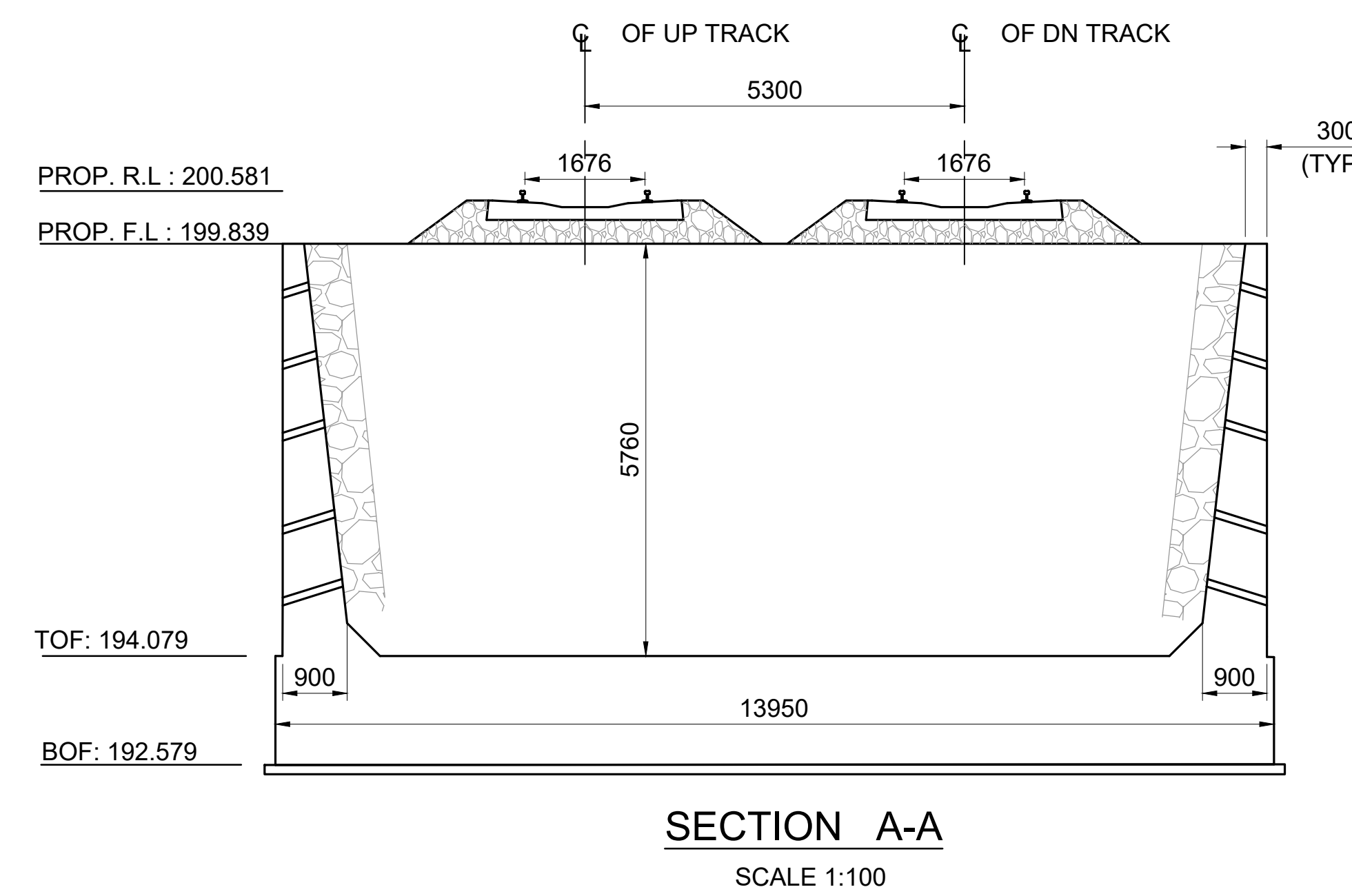
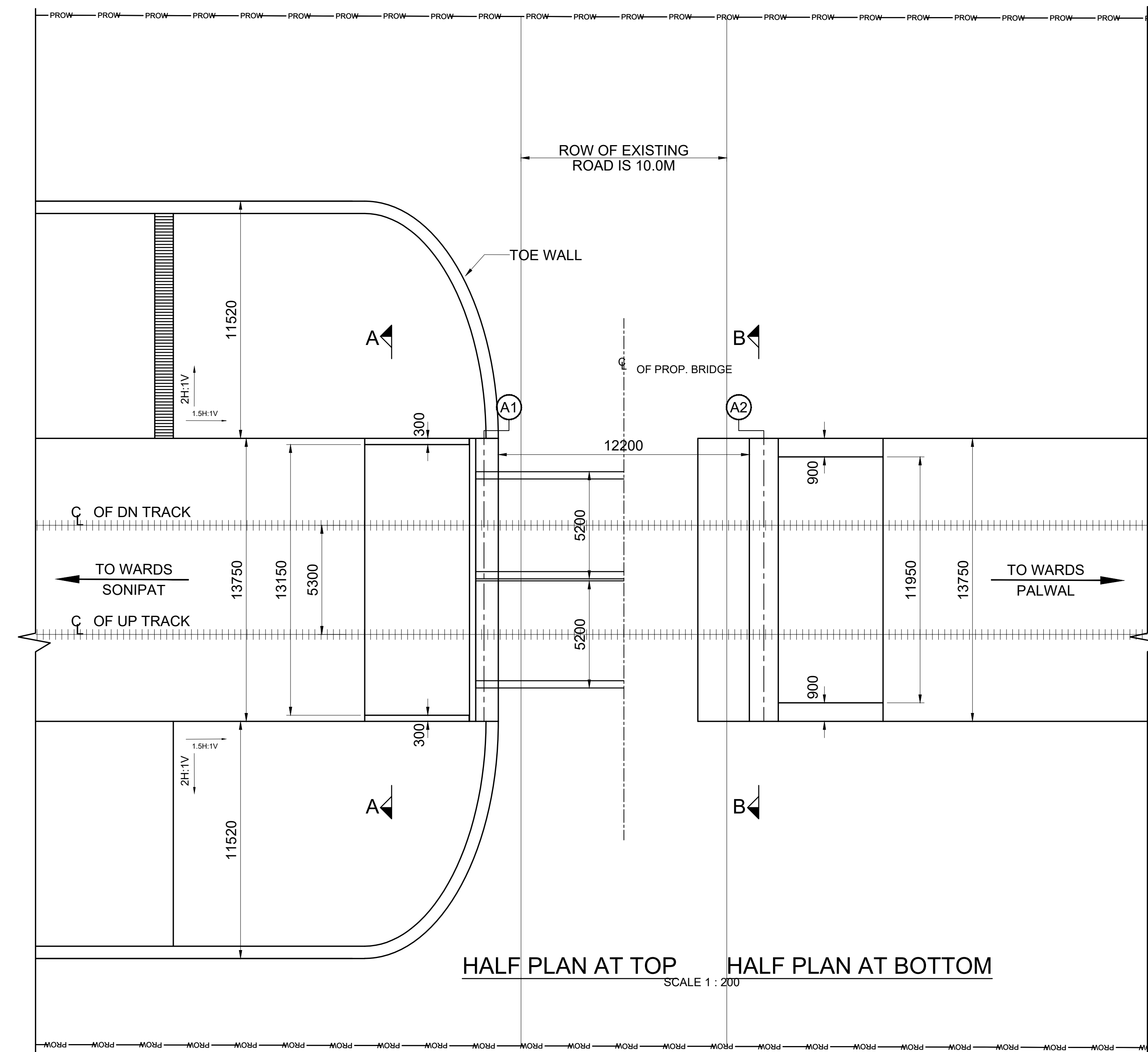

LEGEND

PRL	PROPOSED RAIL LEVEL
PFL	PROPOSED FORMATION LEVEL
HFL	HIGHEST FLOOD LEVEL
GL	GROUND LEVEL
TOF	TOP OF FOUNDATION
BOF	BOTTOM OF FOUNDATION

PROJECT:
HARYANA ORBITAL RAIL CORRIDOR
CONNECTING PALWAL TO SONIPAT BYPASSING DELHI AREA BY LINKING ASAOTI-PATLI-SULTANPUR-ASAUDAH BY NEW ELECTRIFIED BG DOUBLE LINE

CLIENT:
 HARYANA RAIL INFRASTRUCTURE DEVELOPMENT CORPORATION LIMITED.

CONSULTANT:
 GENERAL CONSULTANT FOR HARYANA ORBITAL RAIL CORRIDOR
RITES Limited in consortium with SMEC International Pty. Ltd.



TITLE:- CONCEPTUAL GENERAL ARRANGEMENT DRAWING
PROPOSED RUB NO. 062
1 x 12.2m PSC U SLAB CH: 17500

DRG. NO. GC-HRIDC-C4-DRW-BRD-GAD-01062_A2 **SHEET NO.** 1 OF 1

SCALE : AS SHOWN **ISSUE DATE** 07-11-2022 **REVISED DATE** 10-01-2023

GC/HORC		HRIDC	
NAME / DESIGNATION	SIGN	NAME / DESIGNATION	SIGN
CHAHATEY RAM PD		SHIV OM DWIVEDI CPM/HRIDC	
SUDHIR AGRAWAL DPD/CIVIL		RAJU SOLANKI DGM/CIVIL/SOUTH	
REETU PATIAL CDE/ CIVIL			

Miscellaneous Drawings (Conceptual Plans)

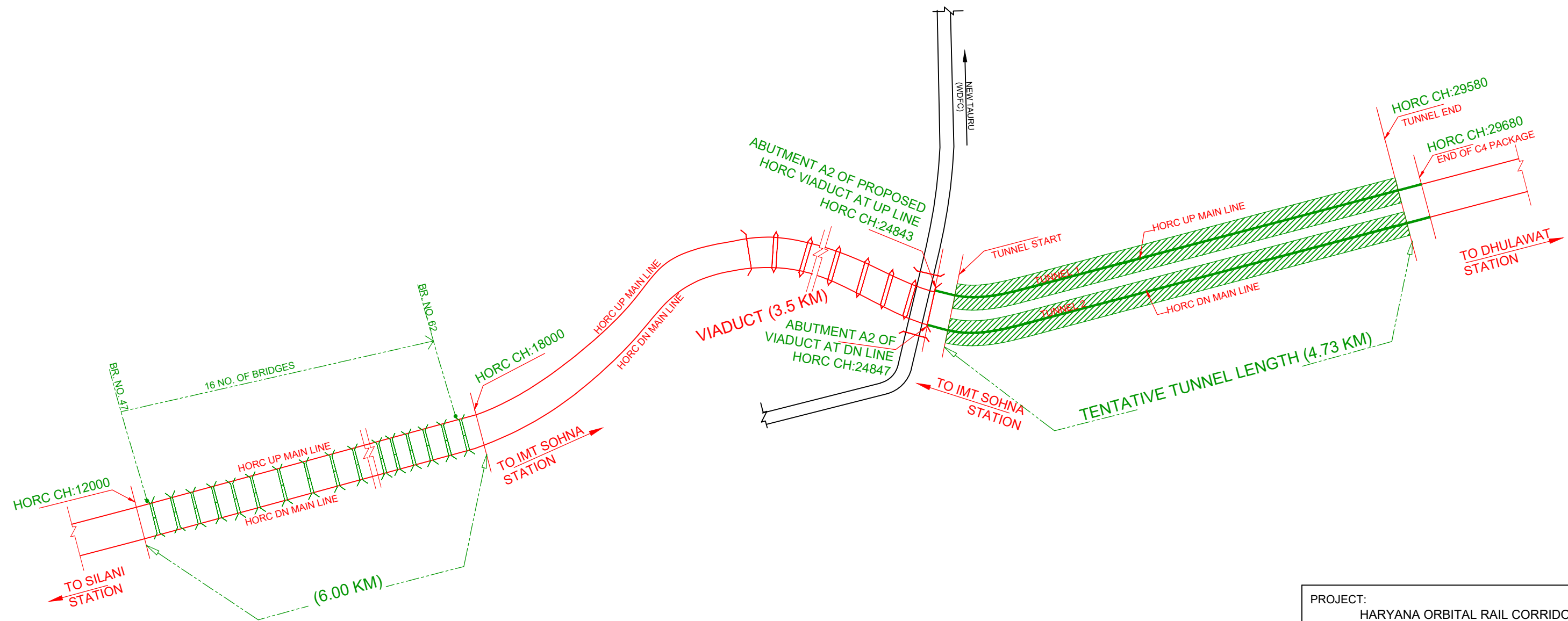

NOTES:

- JURISDICTION OF C4 PACKAGE SHOWN IN GREEN COLOUR.
- CHAINAGES SHOWN ARE RECKONED FROM C/L OF PRITHALA STATION BUILDING TAKEN AS 0.00m, WITH RESPECT TO UP MAIN LINE.

PROJECT:
HARYANA ORBITAL RAIL CORRIDOR
 CONNECTING PALWAL TO SONIPAT BYPASSING DELHI AREA BY LINKING ASAOTI-PATLI-SULTANPUR-ASAUDAH BY NEW ELECTRIFIED BG DOUBLE LINE

CLIENT:
 **HARYANA RAIL INFRASTRUCTURE DEVELOPMENT CORPORATION LIMITED.**

CONSULTANT:
 **GENERAL CONSULTANT FOR HARYANA ORBITAL RAIL CORRIDOR**
 RITES Limited in consortium with SMEC International Pty. Ltd.



TITLE:- JURISDICTIONAL SKETCH OF C-4 PACKAGE

GC/HORC		HRIDC	
NAME / DESIGNATION	SIGN	NAME / DESIGNATION	SIGN
CHAHATEY RAM PD	<i>Chahatey Ram</i>	SHIV OM DWIVEDI CPM/HRIDC	<i>Shiv</i>
SUDHIR AGRAWAL DPD/CIVIL	<i>ASD</i>	RAJU SOLANKI DGM/CIVIL/SOUTH	<i>Raju</i>
REETU PATIAL CDE/ CIVIL	<i>Reetu</i>		

SKETCH NO. GC-HRIDC-C4-SK-CIVIL-001_A1	SHEET NO.
SCALE : AS SHOWN	ISSUE DATE 07-11-2022
	REVISED DATE 09.01.2023

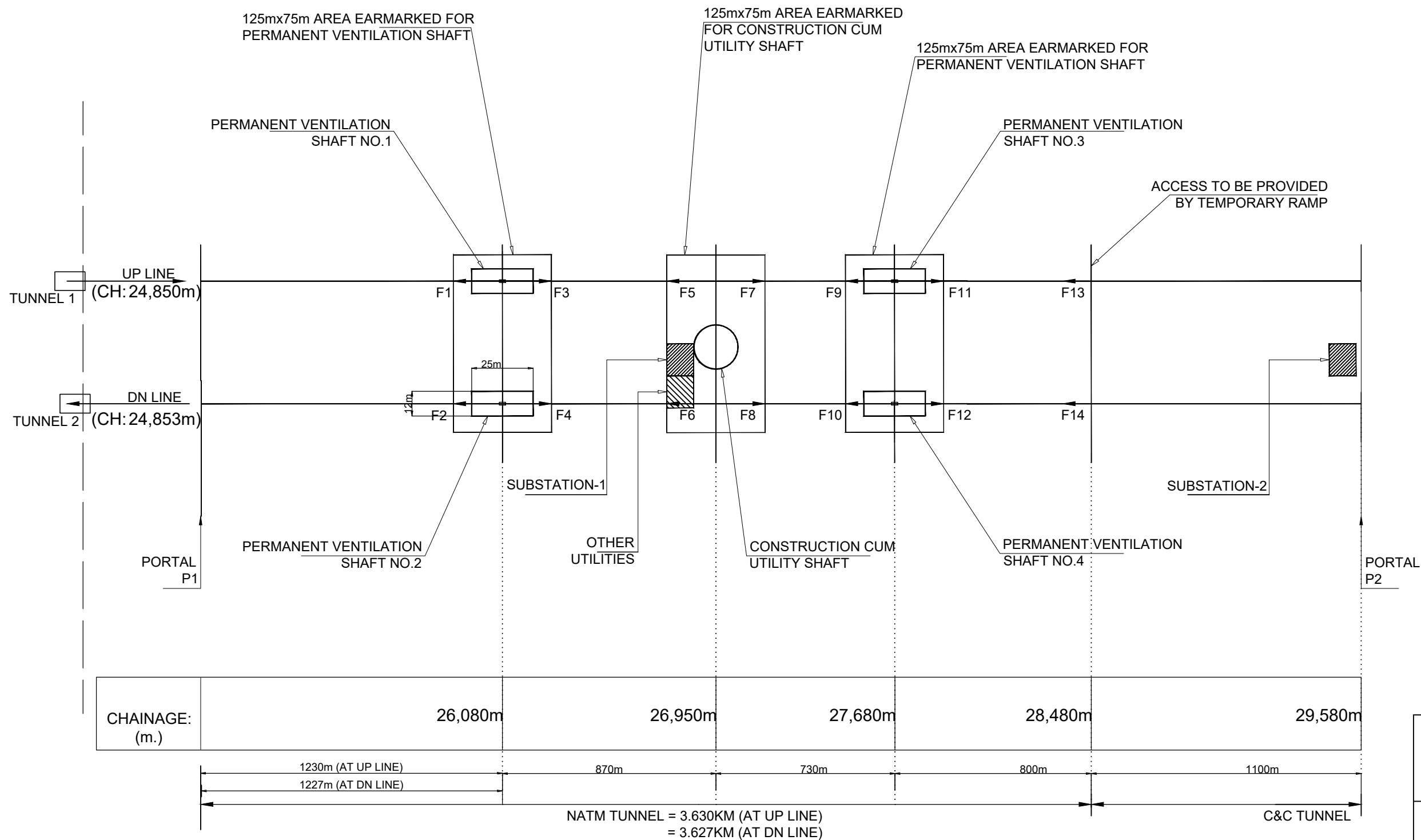

PROJECT:
HARYANA ORBITAL RAIL CORRIDOR
 CONNECTING PALWAL TO SONIPAT BYPASSING DELHI AREA BY LINKING ASAOOTI-PATLI-SULTANPUR-ASAUDAH BY NEW ELECTRIFIED BG DOUBLE LINE

CLIENT:

HARYANA RAIL INFRASTRUCTURE DEVELOPMENT CORPORATION LIMITED.

CONSULTANT:

GENERAL CONSULTANT FOR HARYANA ORBITAL RAIL CORRIDOR
 RITES Limited in consortium with SMEC International Pty. Ltd.



TITLE:- SCHEMATIC DIAGRAM OF HRC TUNNEL

SKETCH NO. GC-HRIDC-C4-SK-TUNNEL-001_A1 **SHEET NO.**

SCALE : AS SHOWN **ISSUE DATE:** 07-11-2022 **REVISED DATE:** 09.01.2023

- NOTES:**
- F1 - F14 ARE THE WORKING FACES OF NATM TUNNEL.
 - CHAINAGES SHOWN ARE RECKONED FROM C/L OF PRITHALA STATION BUILDING TAKEN AS 0.00m, WITH RESPECT TO UP MAIN LINE.

GC/HORC		HRIDC	
NAME / DESIGNATION	SIGN	NAME / DESIGNATION	SIGN
CHAHATEY RAM PD	<i>Chahatey Ram</i>	SHIV OM DWIVEDI CPM/HRIDC	<i>Shiv</i>
SUDHIR AGRAWAL DPD/CIVIL	<i>ASh</i>	RAJU SOLANKI DGM/CIVIL/SOUTH	<i>Raju</i>
REETU PATIAL CDE/ CIVIL	<i>Reetu</i>		

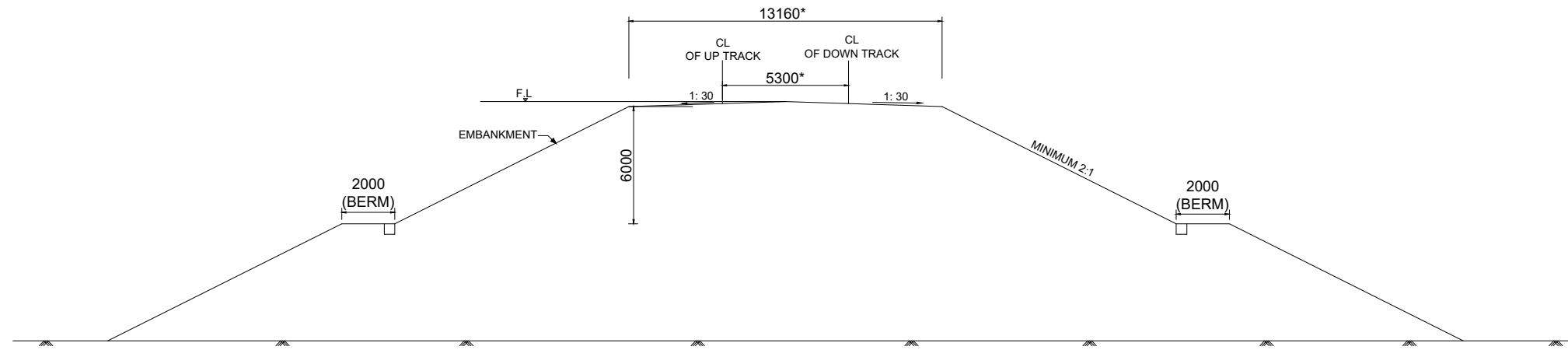

TYPICAL CROSS-SECTION OF EMBANKMENT
(FOR DOUBLE TRACK)

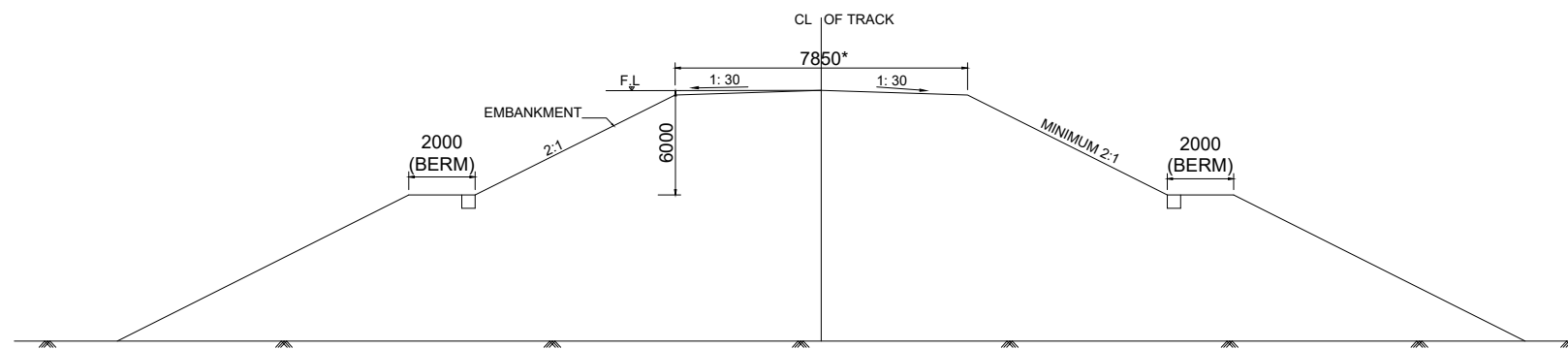

TYPICAL CROSS-SECTION OF EMBANKMENT
(FOR SINGLE TRACK)

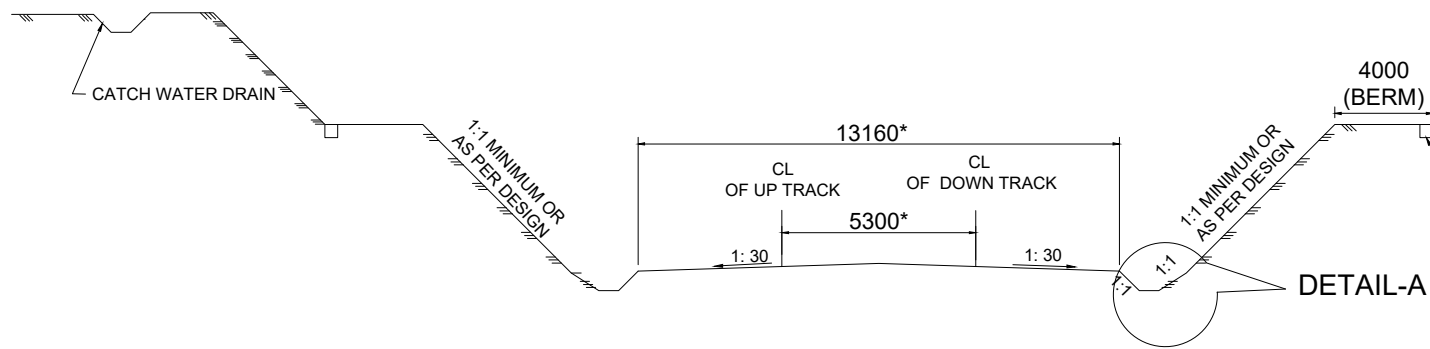

TYPICAL CROSS-SECTION OF CUTTING
(FOR DOUBLE TRACK)

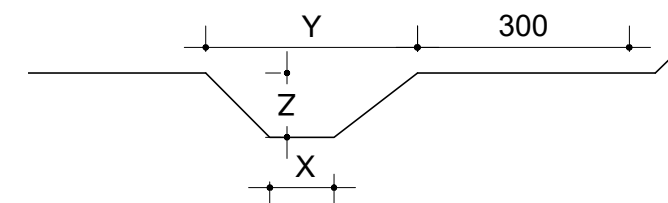

DETAIL-A

- NOTES:
1. ALL DIMENSIONS ARE IN MILLIMETERS UNLESS OTHERWISE SPECIFIED.
 2. NO DIMENSION SHALL BE SCALED FROM DRAWING ONLY WRITTEN DIMENSIONS ARE TO BE FOLLOWED.
 3. DEPTH OF BALLAST CUSHION SHOULD BE PROVIDED AS PER PARA 212(2) OF IRPWM.
 4. CROSS SLOPE OF 1 IN 30 SHALL BE PROVIDED.
 5. MINIMUM FORMATION WIDTH OF 13160 MM SHALL BE ENSURED FOR NEW WORKS IN BOTH EMBANKMENT AND IN CUTTING (EXCLUDING SIDE DRAIN)
 6. * FORMATION WIDTH SHALL BE INCREASED BASED ON CURVE & SUPER ELEVATION AS PER IRSOD.
 7. X, Y, Z DIMENSIONS SHALL BE AS PER DESIGN.

PROJECT:
HARYANA ORBITAL RAIL CORRIDOR
CONNECTING PALWAL TO SONIPAT BYPASSING DELHI AREA BY LINKING ASAOTI-PATLI-SULTANPUR-ASAUDAH BY NEW ELECTRIFIED BG DOUBLE LINE

CLIENT:
 HARYANA RAIL INFRASTRUCTURE DEVELOPMENT CORPORATION LIMITED





CONSULTANT:
 GENERAL CONSULTANT FOR HARYANA ORBITAL RAIL CORRIDOR
RITES Limited in consortium with SMEC International Pty. Ltd.



TITLE:- CONCEPTUAL PLAN
TYPICAL EMBANKMENT/CUTTING PROFILE

DRG. NO. GC-HRIDC-SK-GEN-001_A2 SHEET NO.

SCALE : AS SHOWN
ISSUE DATE 07-11-2022
REVISED DATE 09.01.2023

GC/HORC		HRIDC	
NAME / DESIGNATION	SIGN	NAME / DESIGNATION	SIGN
CHAHATEY RAM PD		R. R. KUMAR GM/ IP&P	
SUDHIR AGRAWAL DPD/CIVIL		RAJU SOLANKI DGM/C-SOUTH	
REETU PATIAL CDE/ CIVIL			

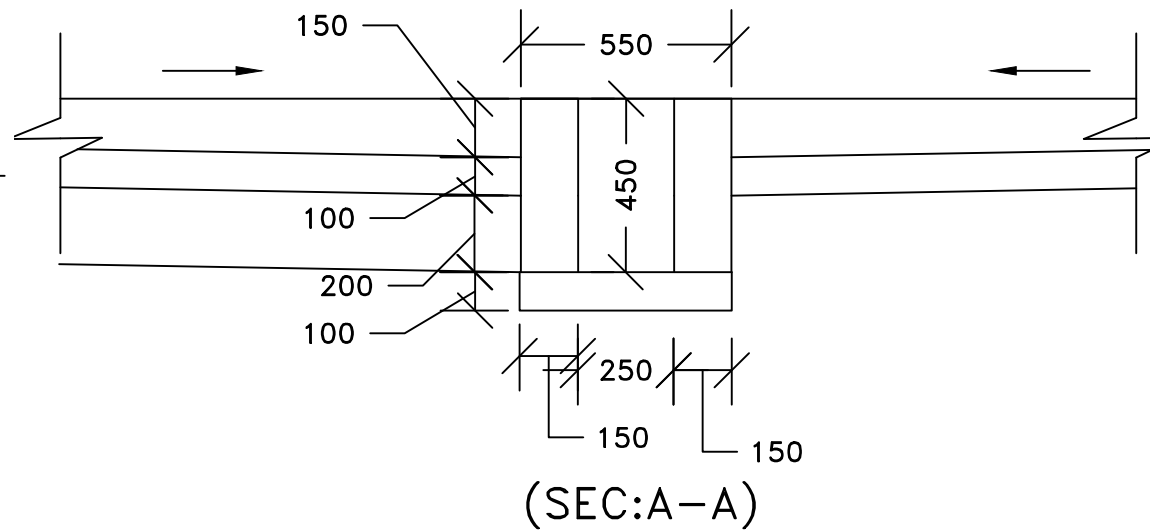
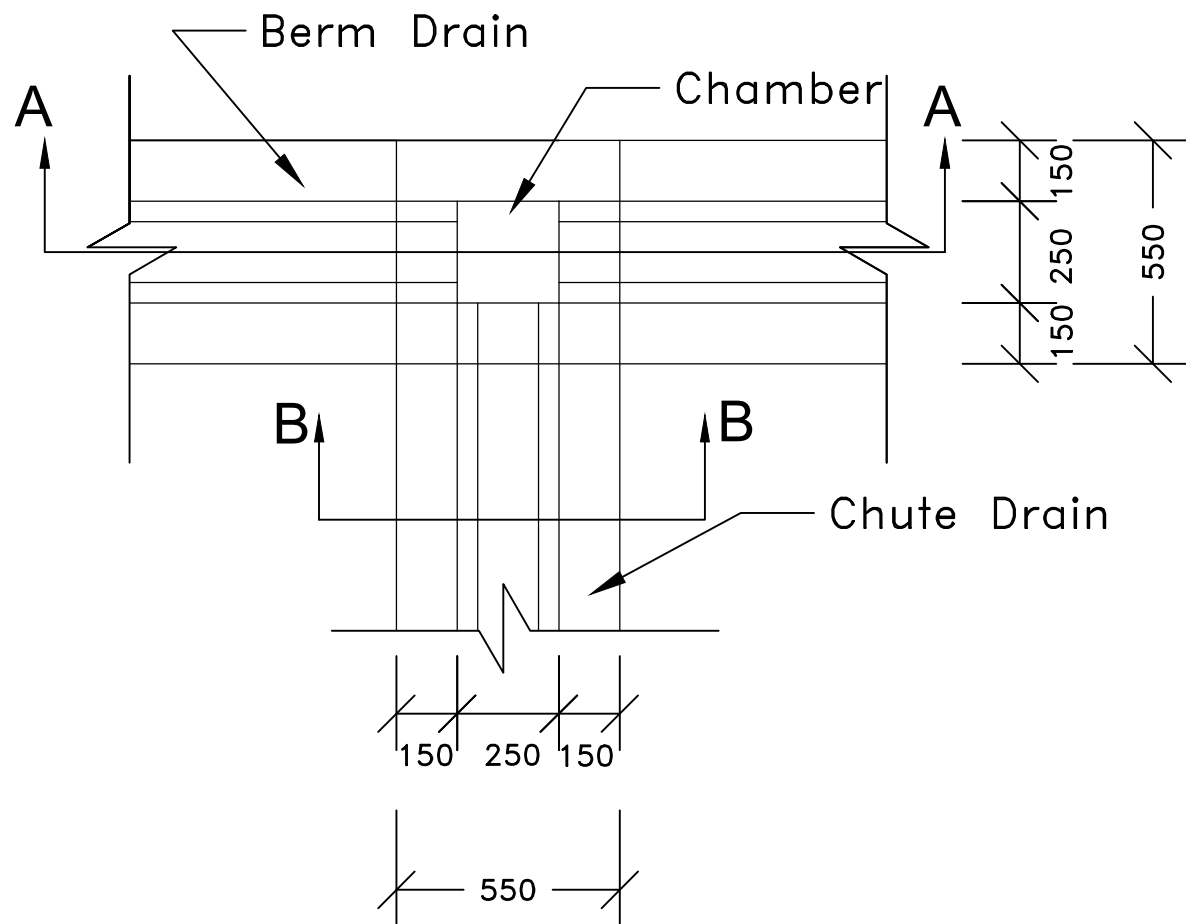
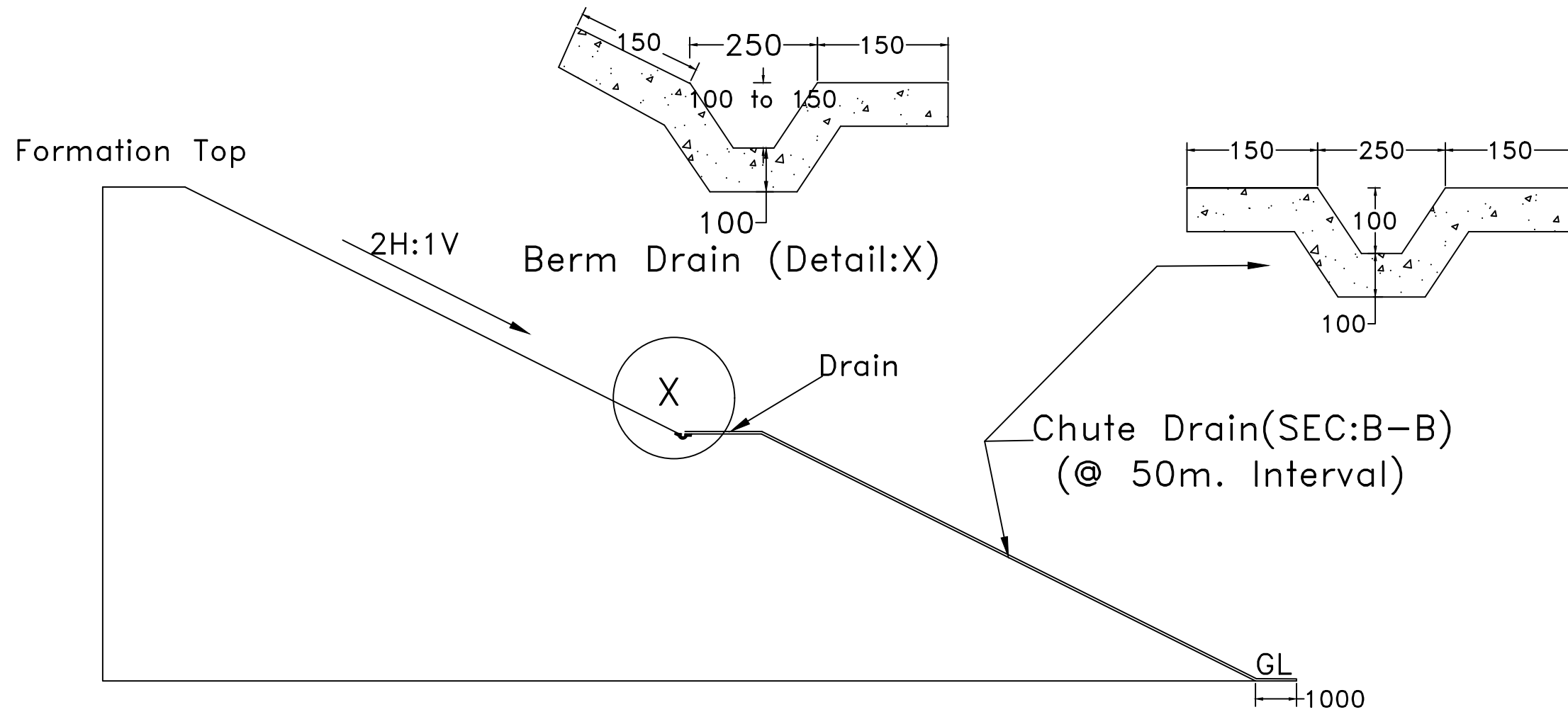

- Note:-
1. ALL DIMENSIONS ARE IN MILLIMETERS UNLESS OTHERWISE SPECIFIED.
 2. NO DIMENSION SHALL BE SCALED FROM DRAWING ONLY WRITTEN DIMENSIONS ARE TO BE FOLLOWED.
 3. ALL CAST IN-SITU CONCRETE SHALL BE M25.
 4. IN CASE OF PRECAST RCC DRAINS GRADE OF CONCRETE SHALL BE AS PER DESIGN.

PROJECT:
HARYANA ORBITAL RAIL CORRIDOR
CONNECTING PALWAL TO SONIPAT BYPASSING DELHI
AREA BY LINKING ASAOTI-PATLI-SULTANPUR-ASAUDAH BY
NEW ELECTRIFIED BG DOUBLE LINE

CLIENT:
HARYANA RAIL INFRASTRUCTURE
DEVELOPMENT CORPORATION LIMITED.

CONSULTANT:
GENERAL CONSULTANT FOR
HARYANA ORBITAL RAIL CORRIDOR
RITES Limited in consortium with SMEC International Pty. Ltd.



TITLE:- CONCEPTUAL PLAN
DRAINS FOR EMBANKMENT

SKETCH NO. GC-HRIDC-SK-GEN-008_A2 SHEET NO.

SCALE : AS SHOWN
ISSUE DATE: 07-11-2022
REVISED DATE: 09.01.2023

GC/HORC		HRIDC	
NAME / DESIGNATION	SIGN	NAME / DESIGNATION	SIGN
CHAHATEY RAM PD	<i>Chahatey Ram</i>	SHIV OM DWIVEDI CPM/HRIDC	<i>Shiv</i>
SUDHIR AGRAWAL DPD/CIVIL	<i>Shd</i>	RAJU SOLANKI DGM/CIVIL/SOUTH	<i>Raju</i>
REETU PATIAL CDE/ CIVIL	<i>Reetu</i>		

NOTES :

1. ALL DIMENSIONS ARE IN MILLIMETERS AND ALL LEVELS ARE IN METER.
2. CHAINAGES SHOWN ARE RECKONED FROM C/L OF PRITHALA STATION BUILDING TAKEN AS 0.00m, WITH RESPECT TO UP MAIN LINE.
3. FOR OTHER DETAILS REFER RDSO SPECIFICATION NO. RDSO/2020/GE:IRS-004 SEPTEMBER 2020 "COMPREHENSIVE GUIDELINES AND SPECIFICATIONS FOR RAILWAY FORMATION".

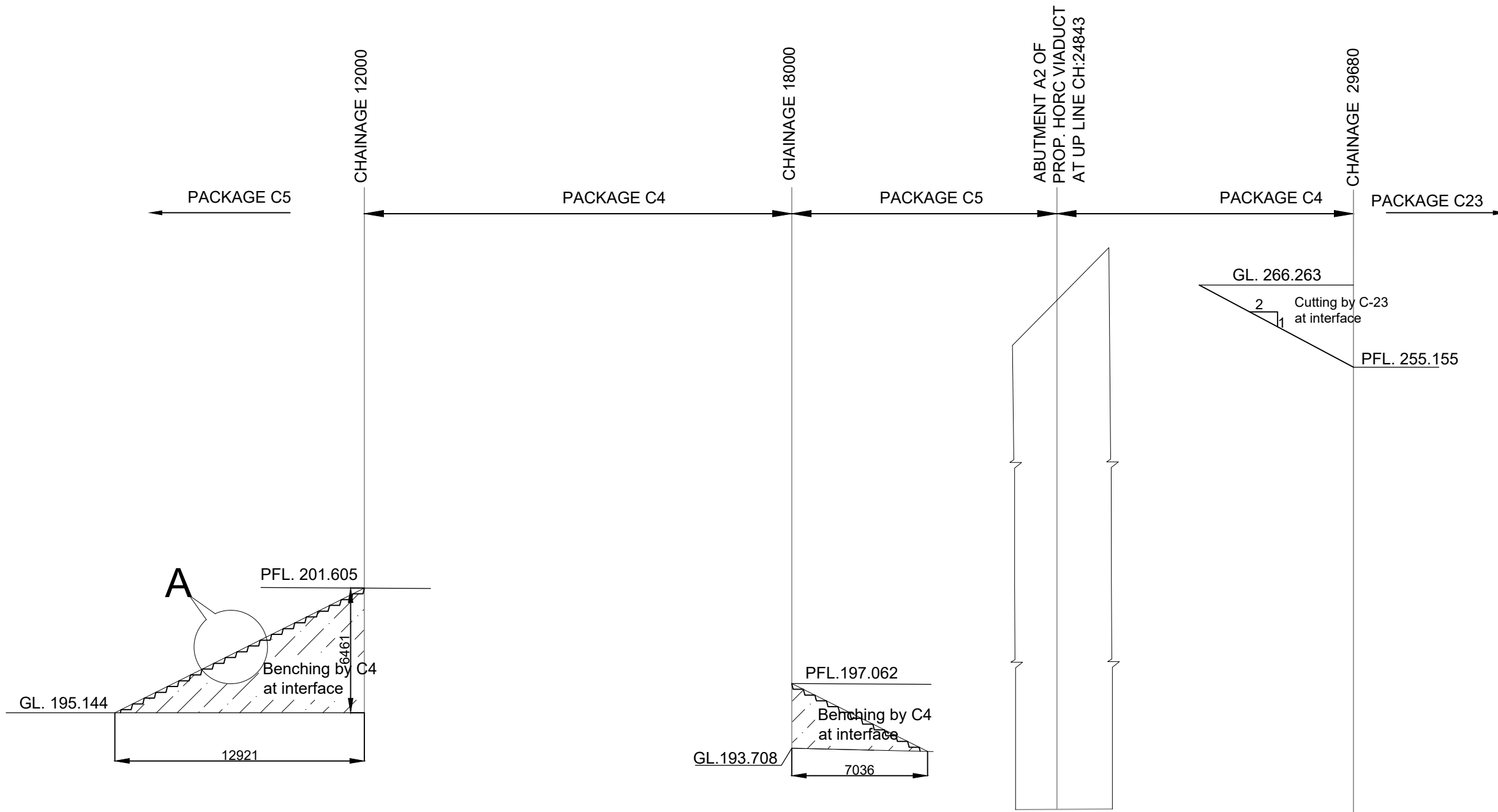

SECTIONAL ELEVATION

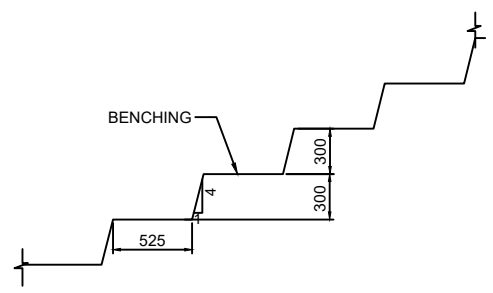
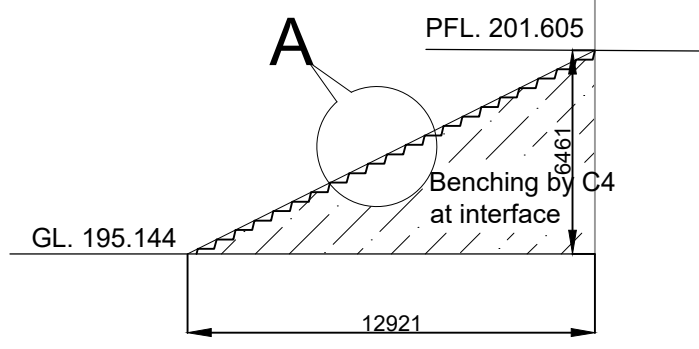

DETAIL -A

PROJECT:
 HARYANA ORBITAL RAIL CORRIDOR
 CONNECTING PALWAL TO SONIPAT BYPASSING DELHI AREA BY LINKING ASAOTI-PATLI-SULTANPUR-ASAUDAH BY NEW ELECTRIFIED BG DOUBLE LINE

CLIENT:
 HARYANA RAIL INFRASTRUCTURE DEVELOPMENT CORPORATION LIMITED.





CONSULTANT:
 GENERAL CONSULTANT FOR HARYANA ORBITAL RAIL CORRIDOR
 RITES Limited in consortium with SMEC International Pty. Ltd.



TITLE:-
 CONCEPTUAL PLAN
 INTERFACING LOCATION BANK BENCHING

SKETCH NO. GC-HRIDC-C4-SK-012_A2 **SHEET NO.** 1 OF 1

SCALE : AS SHOWN **ISSUE DATE:** 21.11.2022 **REVISED DATE:** 10.01.2023

GC/HORC		HRIDC	
NAME / DESIGNATION	SIGN	NAME / DESIGNATION	SIGN
CHAHATEY RAM PD		SHIV OM DWIVEDI CPM/HRIDC	
SUDHIR AGRAWAL DPD/CIVIL		RAJU SOLANKI DGM/CIVIL/SOUTH	
REETU PATIAL CDE/ CIVIL			

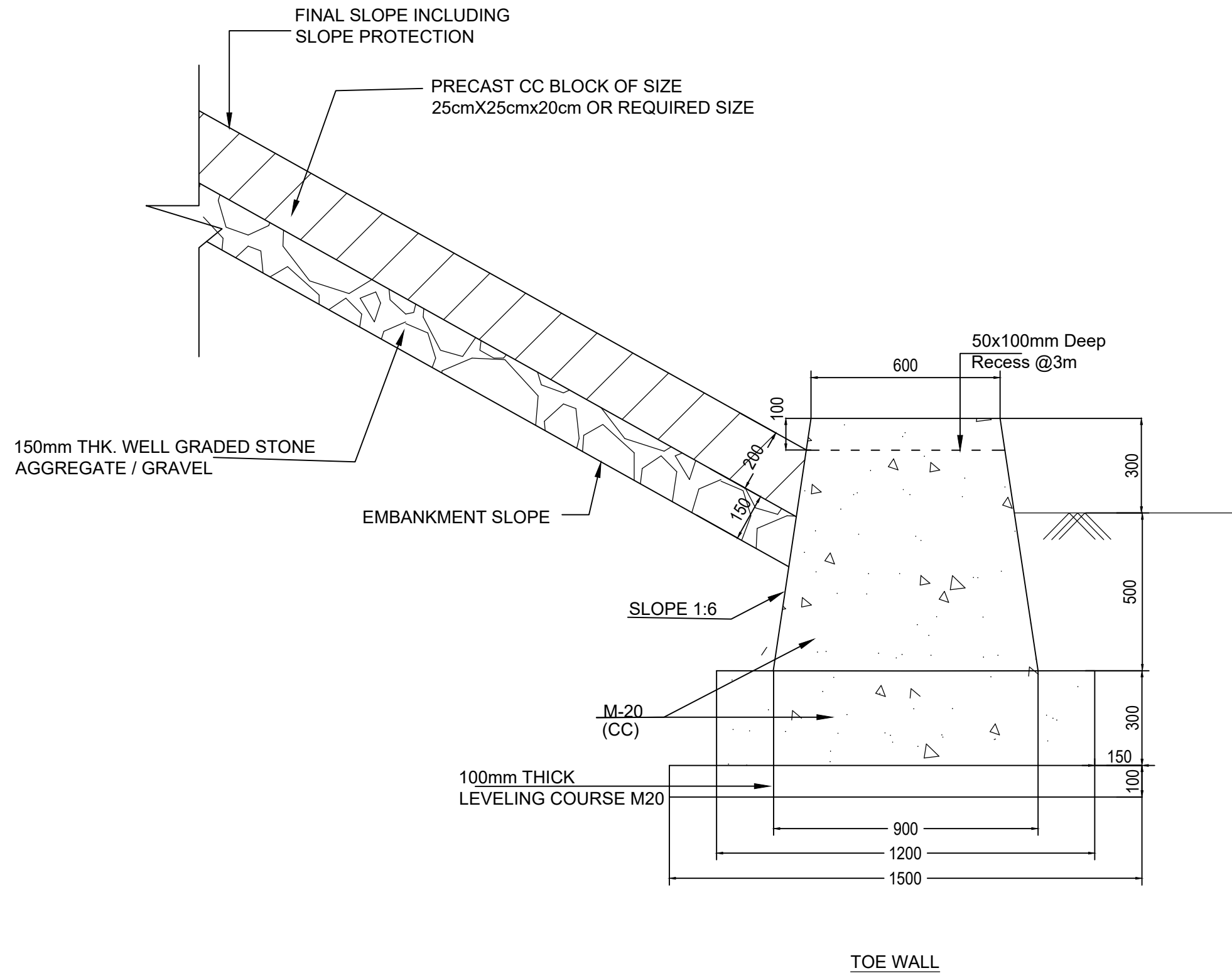

NOTES:-

1. ALL DIMENSIONS ARE IN MILLIMETERS UNLESS OTHERWISE SPECIFIED.
2. NO DIMENSION SHALL BE SCALED FROM DRAWING ONLY WRITTEN DIMENSIONS ARE TO BE FOLLOWED.
3. M-20 GRADE CONCRETE SHALL BE USED FOR TOE WALL.
4. 25MM EXPANSION GAP SHALL BE PROVIDED AT 30m (MAX.) OF LENGTH OF WALL.

PROJECT:
HARYANA ORBITAL RAIL CORRIDOR
 CONNECTING PALWAL TO SONIPAT BYPASSING DELHI AREA BY LINKING ASAOTI-PATLI-SULTANPUR-ASAUDAH BY NEW ELECTRIFIED BG DOUBLE LINE

CLIENT:
 **HARYANA RAIL INFRASTRUCTURE DEVELOPMENT CORPORATION LIMITED.**





CONSULTANT:
 **GENERAL CONSULTANT FOR HARYANA ORBITAL RAIL CORRIDOR**
 RITES Limited in consortium with SMEC International Pty. Ltd.



TITLE:-
 CONCEPTUAL PLAN
 CC TOE WALL

DRG. NO. GC-HRIDC-SK-GEN-014_A2 **SHEET NO.** 1 OF 1

SCALE : AS SHOWN **ISSUE DATE** 28.12.2022 **REVISED DATE** 09.01.2023

GC/HORC		HRIDC	
NAME / DESIGNATION	SIGN	NAME / DESIGNATION	SIGN
CHAHATEY RAM PD		R. R. KUMAR GM/ IP&P	
SUDHIR AGRAWAL DPD/CIVIL		RAJU SOLANKI DGM/C-SOUTH	
REETU PATIAL CDE/ CIVIL			

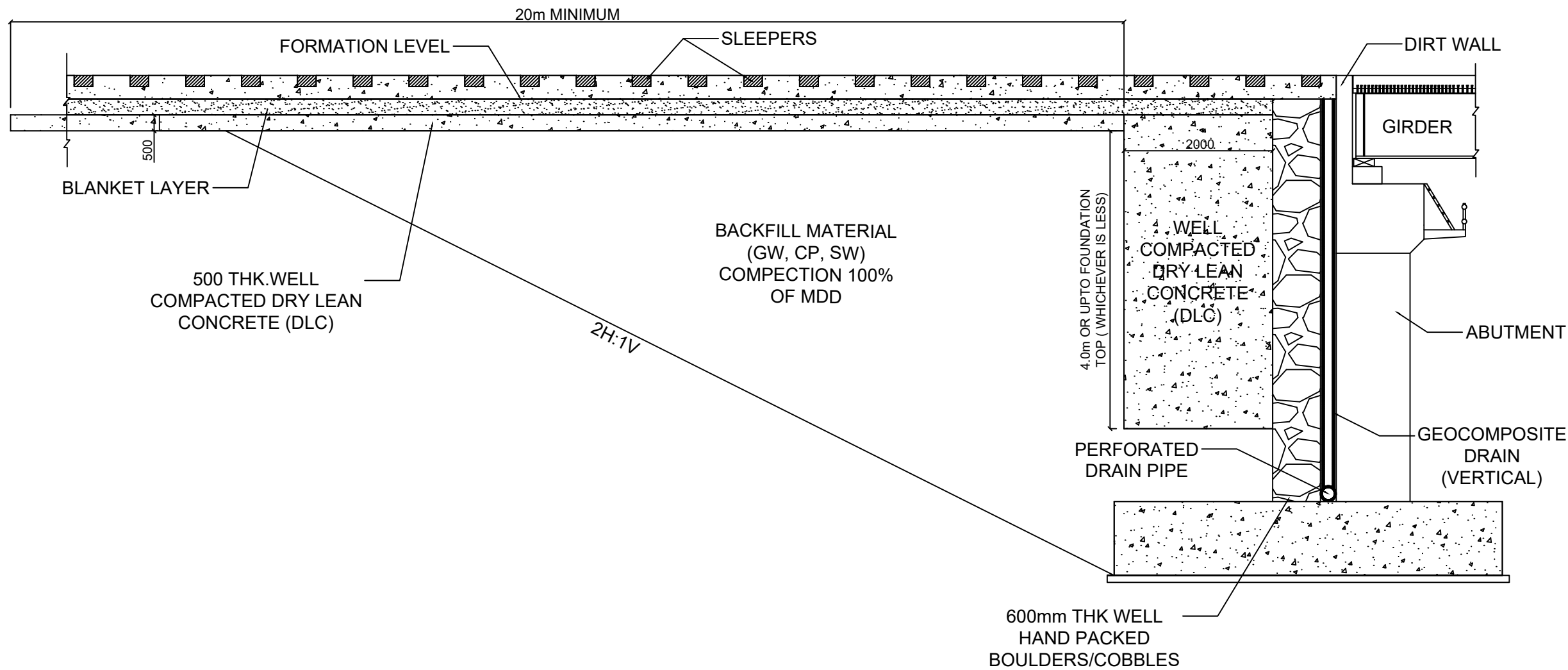

TRANSITION SYSTEM ON APPROACHES OF MAJOR BRIDGES

NOTES:

1. ALL DIMENSIONS ARE IN MILLIMETERS UNLESS OTHERWISE SPECIFIED.
2. NO DIMENSION SHALL BE SCALED FROM DRAWING ONLY WRITTEN DIMENSIONS ARE TO BE FOLLOWED.
3. THIS DRAWING IS PREPARED BASED UPON REFER RDSO REPORT NO. GE:R-50 DATED JULY-2021 FOR DETAILS THIS REPORT SHALL BE FOLLOWED.
4. GEO-COMPOSITE DRAINS TO BE USED BEHIND BRIDGE ABUTMENT SHALL BE AS PER RDSO/2018/GE:IRS-006, MARCH-2019 AND COMPREHENSIVE GUIDELINE AND SPECIFICATIONS FOR RAILWAY FORMATION.
5. PROVISION IN RETURN WALL SHALL BE KEPT TO TAKE OUT THE DISCHARGE FROM PERFORATED DRAIN PIPE.
6. THIS DRAWING SHALL BE USED FOR MAJOR BRIDGE APPROACHES (DEFINITION OF MAJOR BRIDGE SHALL BE AS PER IRBM).

PROJECT:

HARYANA ORBITAL RAIL CORRIDOR
CONNECTING PALWAL TO SONIPAT BYPASSING DELHI AREA BY LINKING ASAOTI-PATLI-SULTANPUR-ASAUDAH BY NEW ELECTRIFIED BG DOUBLE LINE

CLIENT:

 HARYANA RAIL INFRASTRUCTURE DEVELOPMENT CORPORATION LIMITED.

CONSULTANT:

 GENERAL CONSULTANT FOR HARYANA ORBITAL RAIL CORRIDOR
RITES Limited in consortium with SMEC International Pty. Ltd.



TITLE:-

CONCEPTUAL PLAN FOR TRANSITION SYSTEM OF MAJOR BRIDGE APPROACHES

DRG. NO.

GC-HRIDC-SK-GEN-019_A1

SHEET NO.

1 OF 1

SCALE :





AS SHOWN

ISSUE DATE

28.12.2022

REVISED DATE

09.01.2023

GC/HORC		HRIDC	
NAME / DESIGNATION	SIGN	NAME / DESIGNATION	SIGN
CHAHATEY RAM PD		R. R. KUMAR GM/ IP&P	
SUDHIR AGRAWAL DPD/CIVIL		RAJU SOLANKI DGM/C-SOUTH	
REETU PATIAL CDE/ CIVIL			

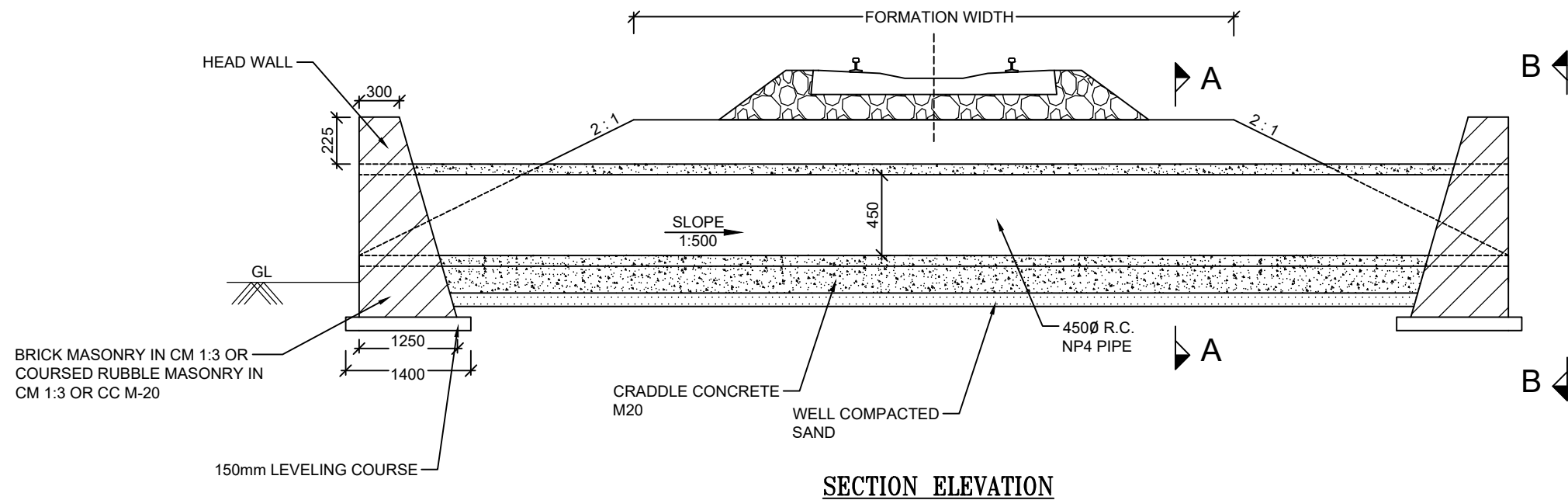

SECTION ELEVATION

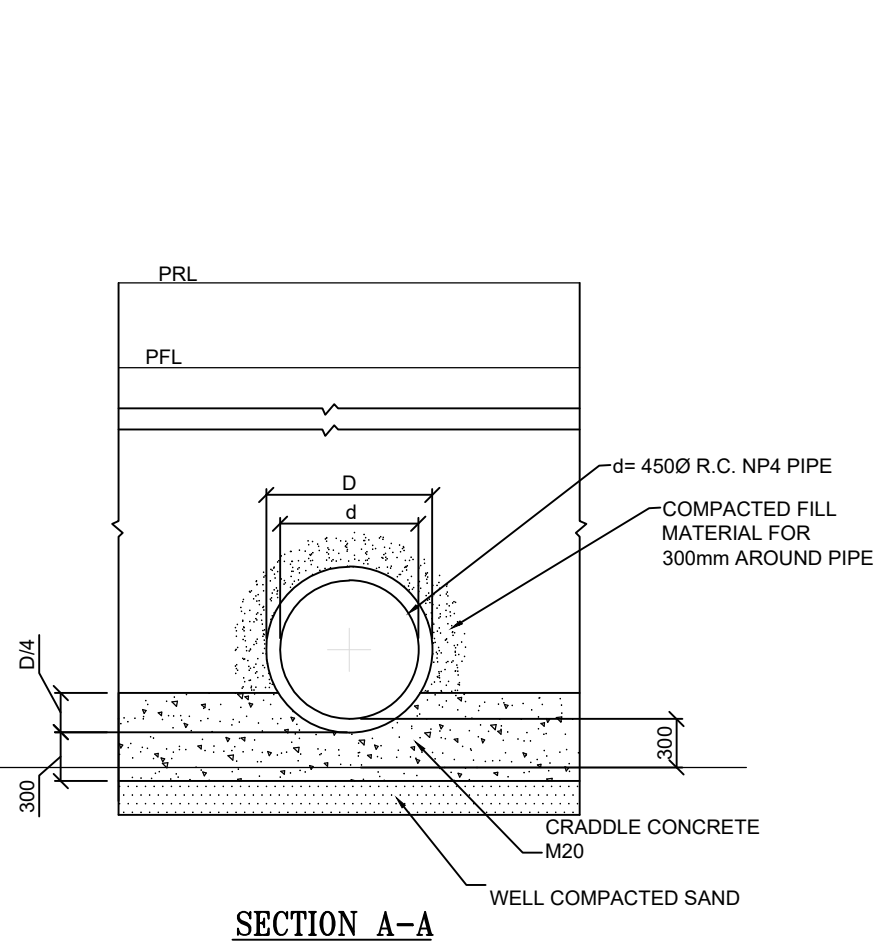

SECTION A-A

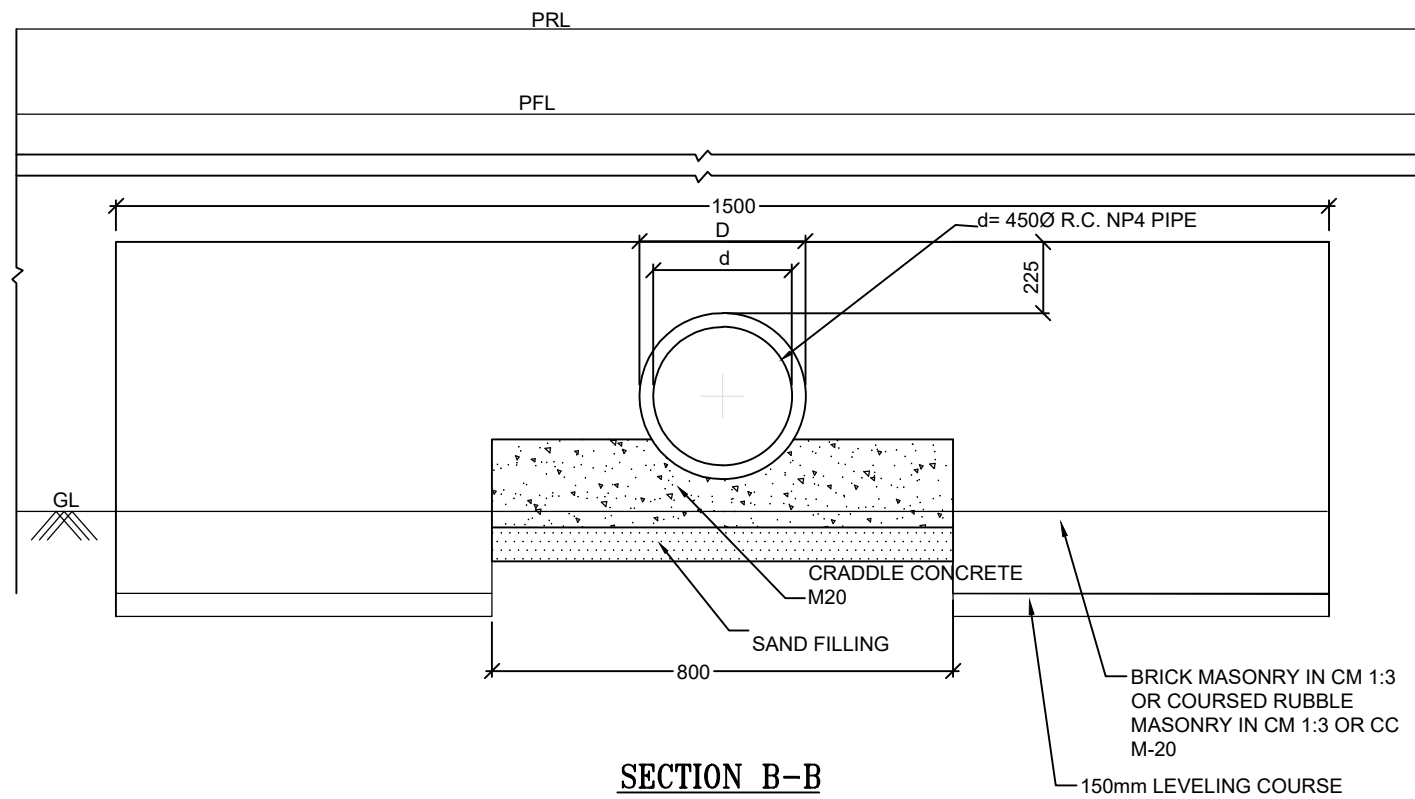

SECTION B-B

- NOTES:
1. ALL DIMENSIONS ARE IN MILLIMETERS UNLESS OTHERWISE SPECIFIED.
 2. NO DIMENSION SHALL BE SCALED FROM DRAWING ONLY WRITTEN DIMENSIONS ARE TO BE FOLLOWED.
 3. LOOSE/UNSUITABLE SOIL BELOW CULVERTS SHALL BE REPLACED WITH SUITABLE GRANULAR MATERIAL.
 4. LONGITUDINAL SLOPE OF PIPE SHALL BE MINIMUM 1 IN 500.
 5. BEDDING CONDITION BELOW NP-04 PIPE SHALL BE AS PER IS:783.





PROJECT:
HARYANA ORBITAL RAIL CORRIDOR
 CONNECTING PALWAL TO SONIPAT BYPASSING DELHI AREA BY LINKING ASAOTI-PATLI-SULTANPUR-ASAUDAH BY NEW ELECTRIFIED BG DOUBLE LINE

CLIENT:
 **HARYANA RAIL INFRASTRUCTURE DEVELOPMENT CORPORATION LIMITED**

CONSULTANT:
 **GENERAL CONSULTANT FOR HARYANA ORBITAL RAIL CORRIDOR**
 RITES Limited in consortium with SMEC International Pty. Ltd.



TITLE:-
 CONCEPTUAL SKETCH FOR NP4 PIPE OF 450mm DIA

GC/HORC		HRIDC	
NAME / DESIGNATION	SIGN	NAME / DESIGNATION	SIGN
CHAHATEY RAM PD		R. R. KUMAR GM/ IP&P	
SUDHIR AGRAWAL DPD/CIVIL		RAJU SOLANKI DGM/C-SOUTH	
REETU PATIAL CDE/ CIVIL			

DRG. NO. GC-HRIDC-SK-GEN-028_A1 SHEET NO. 1 OF 1

SCALE : AS SHOWN ISSUE DATE 28.12.2022 REVISED DATE 10.01.2023

NOTES:

1. ALL DIMENSIONS ARE IN MILLIMETERS UNLESS OTHERWISE SPECIFIED.
2. NO DIMENSION SHALL BE SCALED FROM DRAWING ONLY WRITTEN DIMENSIONS ARE TO BE FOLLOWED.
3. LOOSE/UNSUITABLE SOIL BELOW CULVERTS SHALL BE REPLACED WITH SUITABLE GRANULAR MATERIAL.
4. STRUCTURE IS TO BE DESIGNED FOR 32.5T LOADING AND AVAILABLE FILL AS APPLICABLE.
5. PRECAST BOX SEGMENTS SHALL BE OF MINIMUM 2m LENGTH, JOINED TOGETHER WITH PLUG & SOCKET JOINTS OVER THE BARREL LENGTH.
6. INVERT LEVEL (IL) OF BOX SHALL BE 300mm ABOVE THE GROUND LEVEL.
7. 150mm THICK PCC SHALL BE DONE OVER THE WELL COMPACTED SAND FILLING OR WELL COMPACTED GROUND.

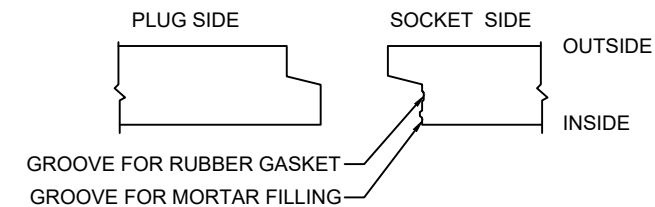
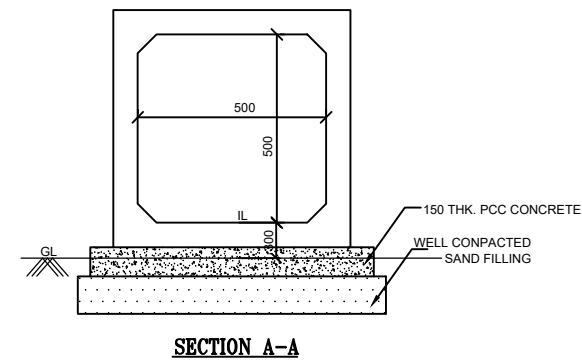
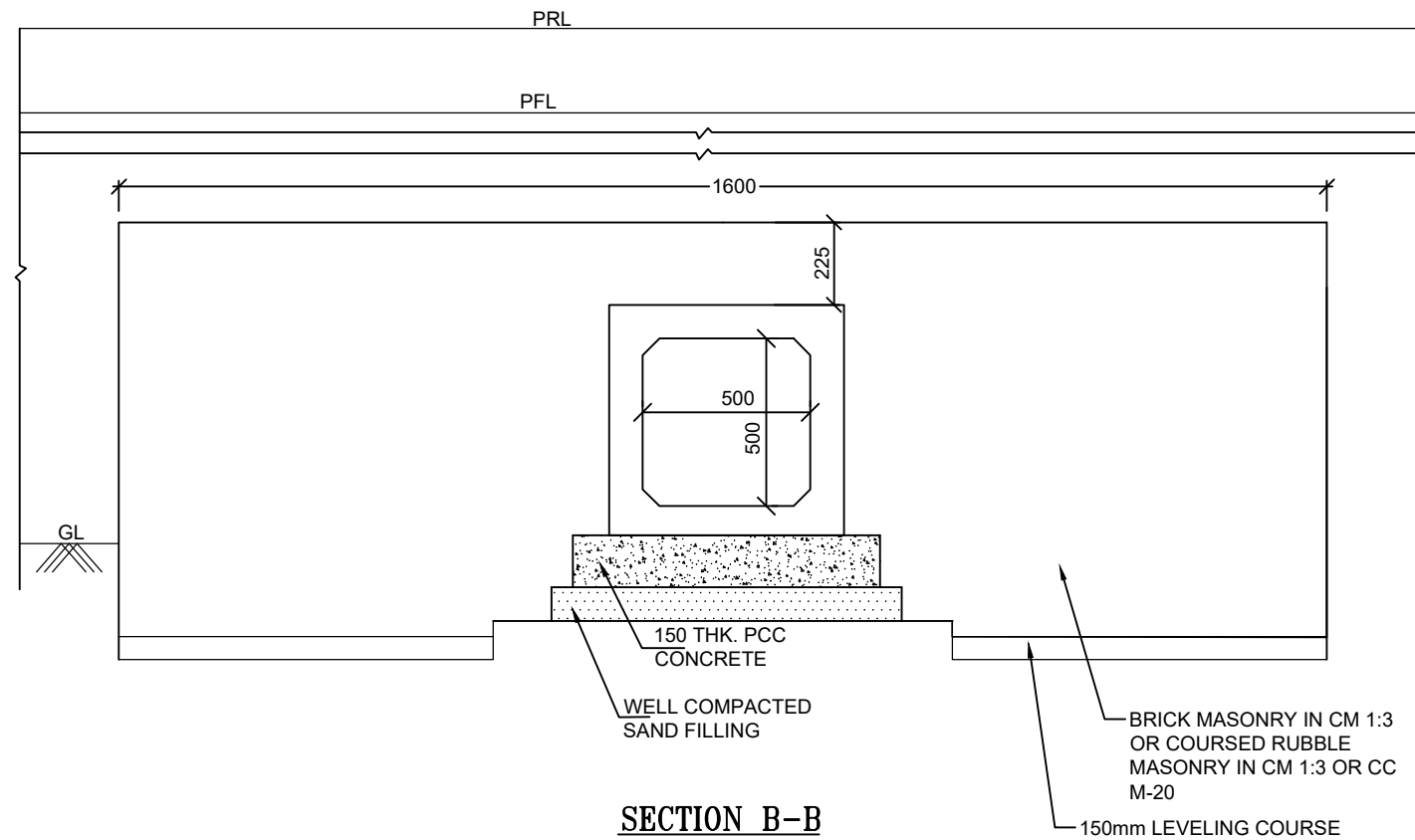
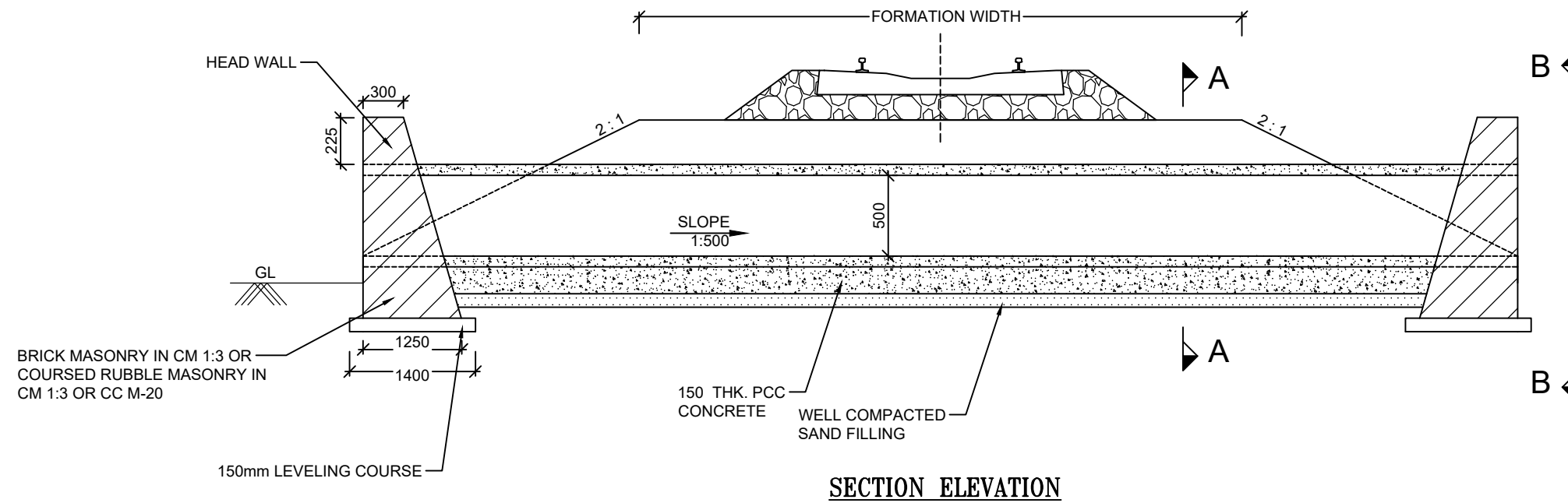

- PLUG & SOCKET JOINTS
- SEALING MATERIAL - RUBBER GASKET

GC/HORC		HRIDC	
NAME / DESIGNATION	SIGN	NAME / DESIGNATION	SIGN
CHAHATEY RAM PD	<i>Chahatey Ram</i>	R. R. KUMAR GM/ IP&P	<i>R.R. Kumar</i>
SUDHIR AGRAWAL DPD/CIVIL	<i>Sudhir</i>	RAJU SOLANKI DGM/C-SOUTH	<i>Raju</i>
REETU PATIAL CDE/ CIVIL	<i>Reetu</i>		

PROJECT:
HARYANA ORBITAL RAIL CORRIDOR
 CONNECTING PALWAL TO SONIPAT BYPASSING DELHI
 AREA BY LINKING ASAOTI-PATLI-SULTANPUR-ASAUDAH BY
 NEW ELECTRIFIED BG DOUBLE LINE

CLIENT:
 **HARYANA RAIL INFRASTRUCTURE
 DEVELOPMENT CORPORATION LIMITED.**

CONSULTANT:
 **GENERAL CONSULTANT FOR
 HARYANA ORBITAL RAIL CORRIDOR**
 RITES Limited in consortium with SMEC International Pty. Ltd.



TITLE:-
 CONCEPTUAL SKETCH FOR
 BOX CULVERT 500 X 500 MM SIZE

DRG. NO. GC-HRIDC-SK-GEN-029_A1 **SHEET NO.** 1 OF 1

SCALE : AS SHOWN **ISSUE DATE** 28.12.2022 **REVISED DATE** 10.01.2023

- NOTES:**
1. ALL DIMENSIONS ARE IN MILLIMETERS EXCEPT LEVELS WHICH ARE IN METER.
 2. FOR HORC RAIL LEVELS, FORMATION LEVEL, GRADES ETC. REFER L-SECTION.
 3. ENGINEER IN CHARGE/SITE ENGINEER SHOULD VERIFY THE RAIL LEVEL, FORMATION LEVEL, BED LEVEL & TRACK CENTER AT SITE BEFORE COMMENCEMENT OF WORK.
 4. ENGINEER IN CHARGE/SITE ENGINEER SHALL ENSURE THE SAFETY OF TRACK/ROAD AT ALL THE TIME AND SHALL TAKE NECESSARY PRECAUTION TO PREVENT DAMAGE OF S&T CABLE /OFC DURING EXECUTION OF WORK CONCERNED DEPT. SUCH AS BSNL/AIRTEL/SSE/SIG/ADSTE ETC. SHALL BE INFORMED WELL IN ADVANCE BEFORE EXECUTION OF WORK.
 5. STRUCTURAL ARRANGEMENT UNDER THE PROPOSED TRACK SHALL BE ON PLANNED AND DESIGNED TO AVOID LOAD TRANSFER TO ANY OF THE STRUCTURE OF ELEVATED ROAD CUM ROB OF DELHI- VADODARA EXPRESSWAY.
 6. ADEQUATE PRECAUTION SHALL BE TAKEN TO AVOID ANY KIND OF DAMAGE TO THE EXISTING STRUCTURE.
 7. CONTRACTOR SHALL PLANT TREES EQUAL TO NUMBER OF TREES AFFECTED DURING CONSTRUCTION.
 8. CONTRACTOR SHALL RESTORE THE DRAIN AFFECTED DUE TO LAYING OF RAIL CROSSING BY PROVIDING PROPER OUTLET AT NEAREST CROSS DRAINAGE STRUCTURE TO THE SATISFACTION OF NHAI.

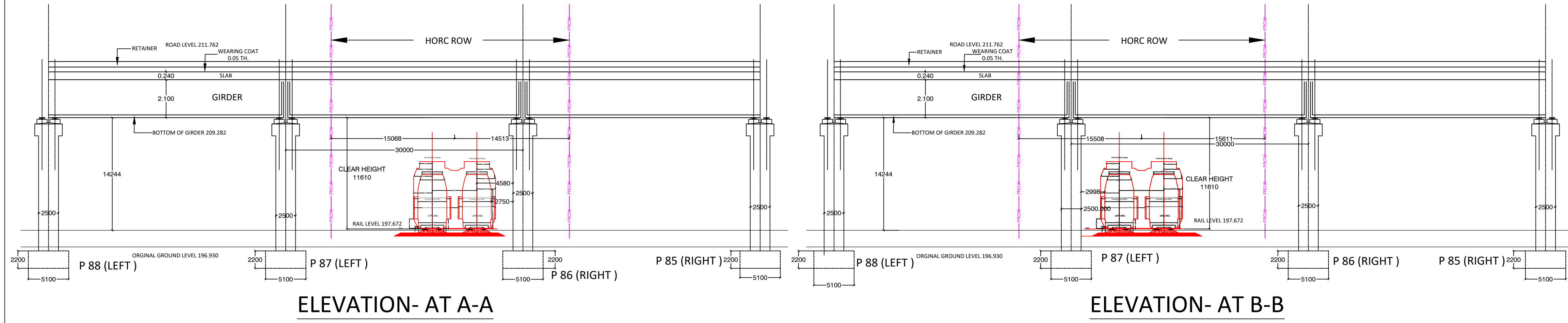

ELEVATION- AT A-A

ELEVATION- AT B-B

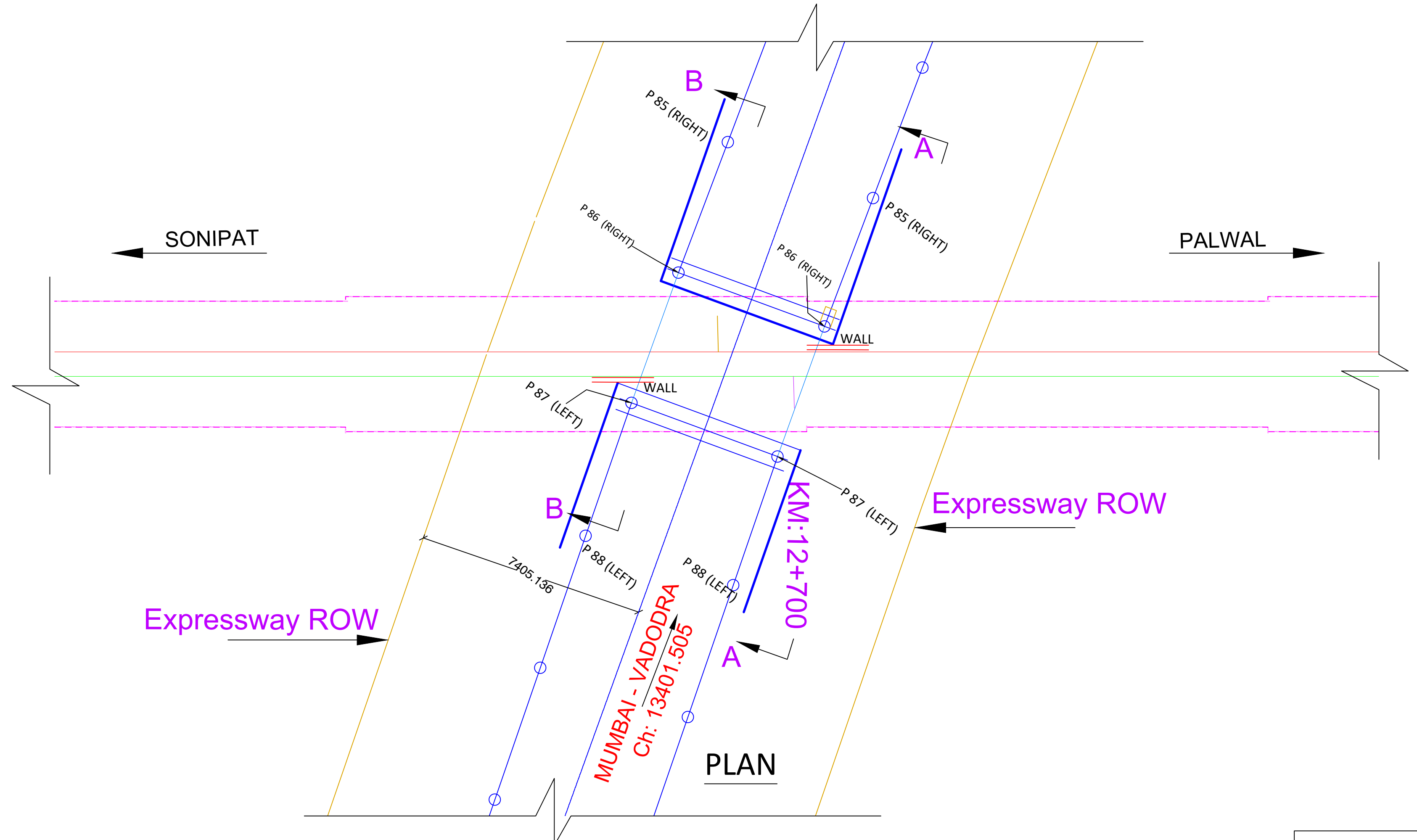





CHAINAGE HORC	13401.505
TOP OF ROAD	211.762
BOTTOM OF EXISTING GIRDER	209.282
HORC RAIL LEVEL	197.672
AVAILABLE VERTICAL CLEARANCE	11.61
BOTTOM OF GIRDER TO RAIL LEVEL	11.610
REQUIRED VERTICAL CLEARANCE	8.50

PROJECT:
HARYANA ORBITAL RAIL CORRIDOR
 CONNECTING PALWAL TO SONIPAT BYPASSING DELHI AREA BY LINKING ASAOTI-PATLI-SULTANPUR-ASAUDAH BY NEW ELECTRIFIED BG DOUBLE LINE

CLIENT:
 **HARYANA RAIL INFRASTRUCTURE DEVELOPMENT CORPORATION LIMITED.**

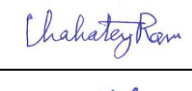
CONSULTANT:
 **GENERAL CONSULTANT FOR HARYANA ORBITAL RAIL CORRIDOR**
 RITES Limited in consortium with SMEC International Pty. Ltd.

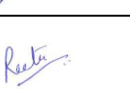
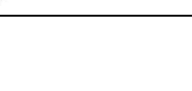

GC/HORC		HRIDC	
NAME / DESIGNATION	SIGN	NAME / DESIGNATION	SIGN
CHAHATEY RAM PD		R. R. KUMAR GM/ IP&P	
SUDHIR AGRAWAL DPD/CIVIL		RAJU SOLANKI DGM/C-SOUTH	
REETU PATIAL CDE/ CIVIL			

TITLE:-
 CONCEPTUAL GENERAL ARRANGEMENT DRAWING CROSSING OF HORC RAIL LINE BELOW VADODARA EXPRESSWAY

DRG. NO. GC-HRIDC-SK-GEN-030_A0 **SHEET NO.** 1 OF 1

SCALE : AS SHOWN **ISSUE DATE** 28.12.2022

- NOTES:
1. ALL DIMENSION ARE IN MILLIMETERS EXPECT LEVELS WHICH ARE IN METERS. NO DIMENSION SHALL BE SCALED FROM DRAWING ONLY WRITTEN DIMENSION ARE TO BE FOLLOWED.
 2. ROAD SHALL BE CONSTRUCTED AS PER MORTH STANDARDS.
 3. ROAD SHALL BE CONSTRUCTED UPTO ROW OF RUB

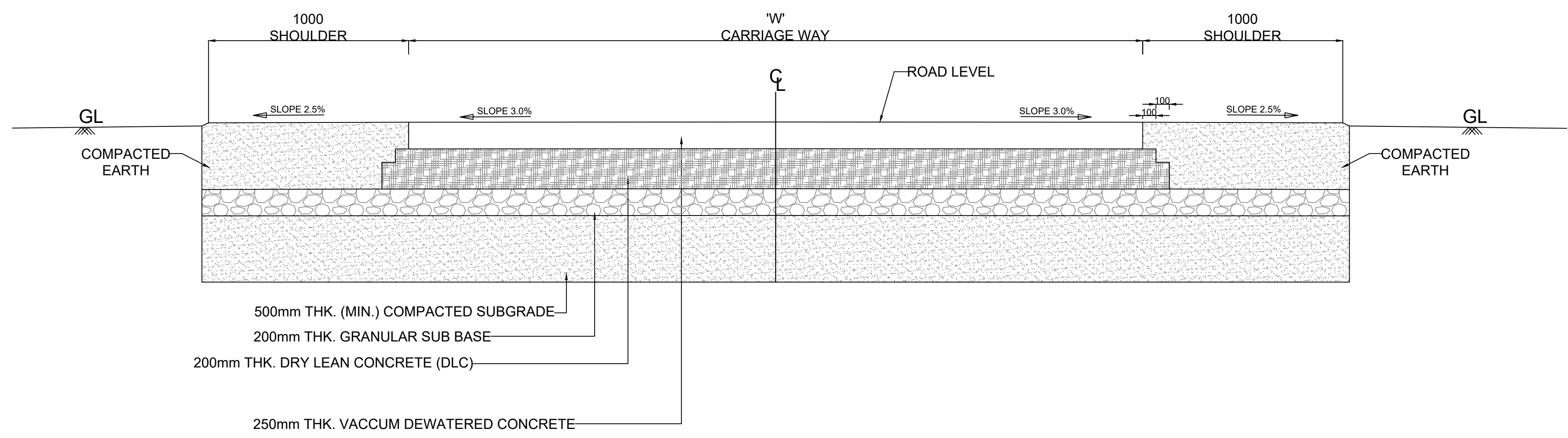

TYPICAL CROSS-SECTION OF ROAD

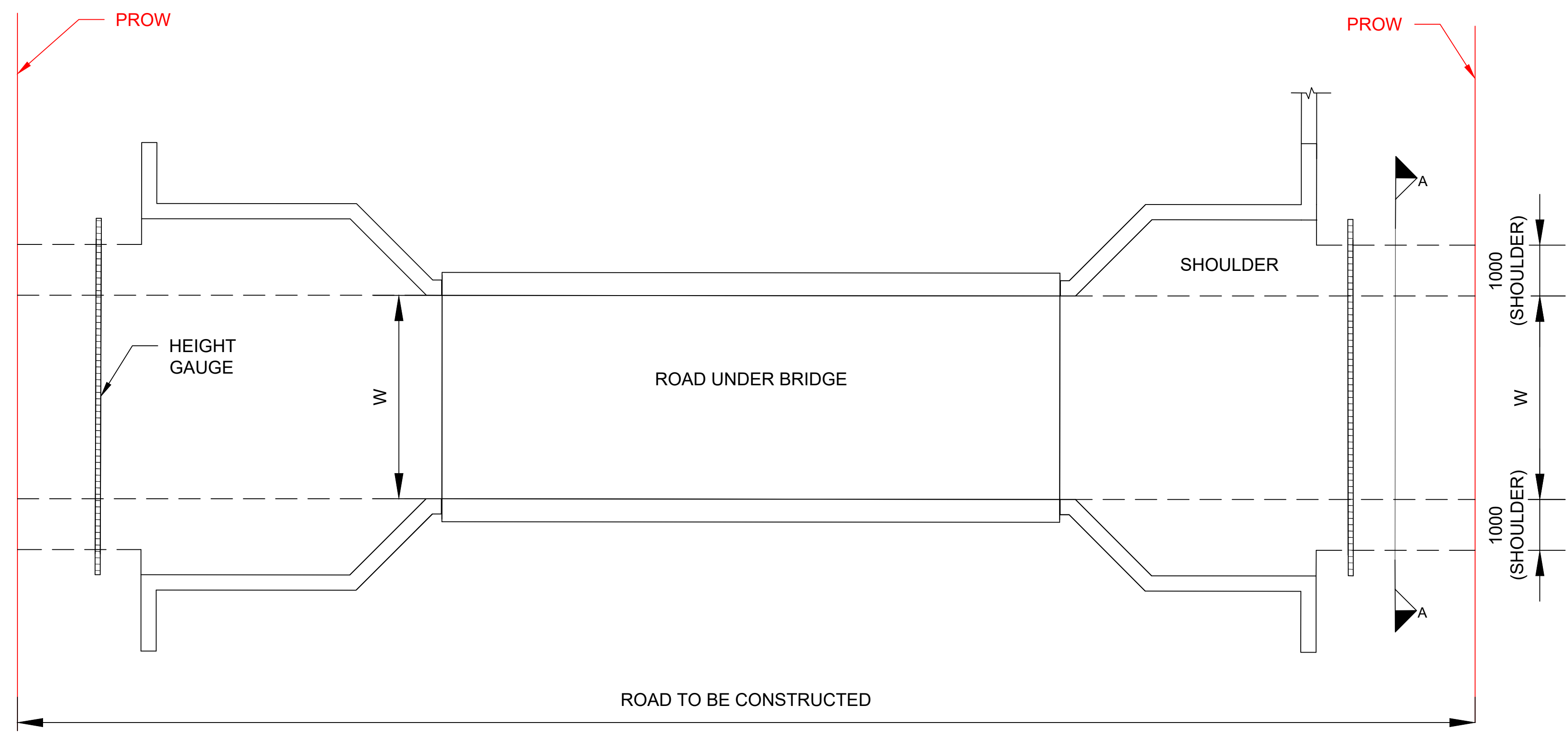

PROJECT:
HARYANA ORBITAL RAIL CORRIDOR
 CONNECTING PALWAL TO SONIPAT BYPASSING DELHI AREA BY LINKING ASAOTI-PATLI-SULTANPUR-ASAUDAH BY NEW ELECTRIFIED BG DOUBLE LINE

CLIENT:
 **HARYANA RAIL INFRASTRUCTURE DEVELOPMENT CORPORATION LIMITED.**

CONSULTANT:
 **GENERAL CONSULTANT FOR HARYANA ORBITAL RAIL CORRIDOR**
 RITES Limited in consortium with SMEC International Pty. Ltd.



TITLE:- **TYPICAL SKETCH FOR APPROACH ROAD OF RUBs**

GC/HORC		HRIDC	
NAME / DESIGNATION	SIGN	NAME / DESIGNATION	SIGN
CHAHATEY RAM PD	<i>Chahatey Ram</i>	R. R. KUMAR GM/ IP&P	<i>R.R. Kumar</i>
SUDHIR AGRAWAL DPD/CIVIL	<i>Sudhir</i>	RAJU SOLANKI DGM/C-SOUTH	<i>Raju Solanki</i>
REETU PATIAL CDE/ CIVIL	<i>Reetu</i>		

DRG. NO. GC-HRIDC-SK-GEN-031_A0 SHEET NO. 1 OF 1

SCALE : AS SHOWN ISSUE DATE 11.01.2023 REVISED DATE

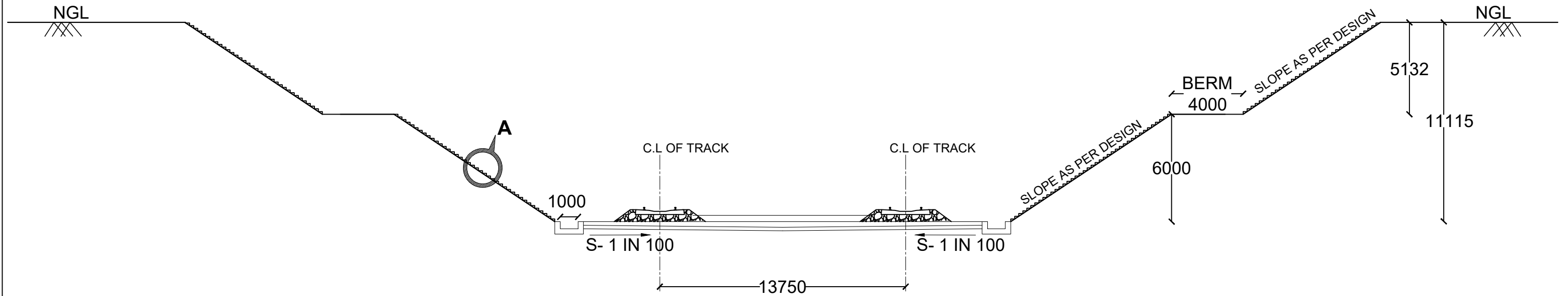

**CROSS SECTION NEAR
END OF CUT & COVER CH: 29590**

NOTES:

1. ALL DIMENSIONS ARE IN MILLIMETERS UNLESS OTHERWISE SPECIFIED.
2. NO DIMENSION SHALL BE SCALED FROM DRAWING ONLY WRITTEN DIMENSIONS ARE TO BE FOLLOWED.
3. CHAINAGES SHOWN ARE RECKONED FROM C/L OF PRITHALA STATION BUILDING TAKEN AS 0.00m, WITH RESPECT TO UP MAIN LINE.

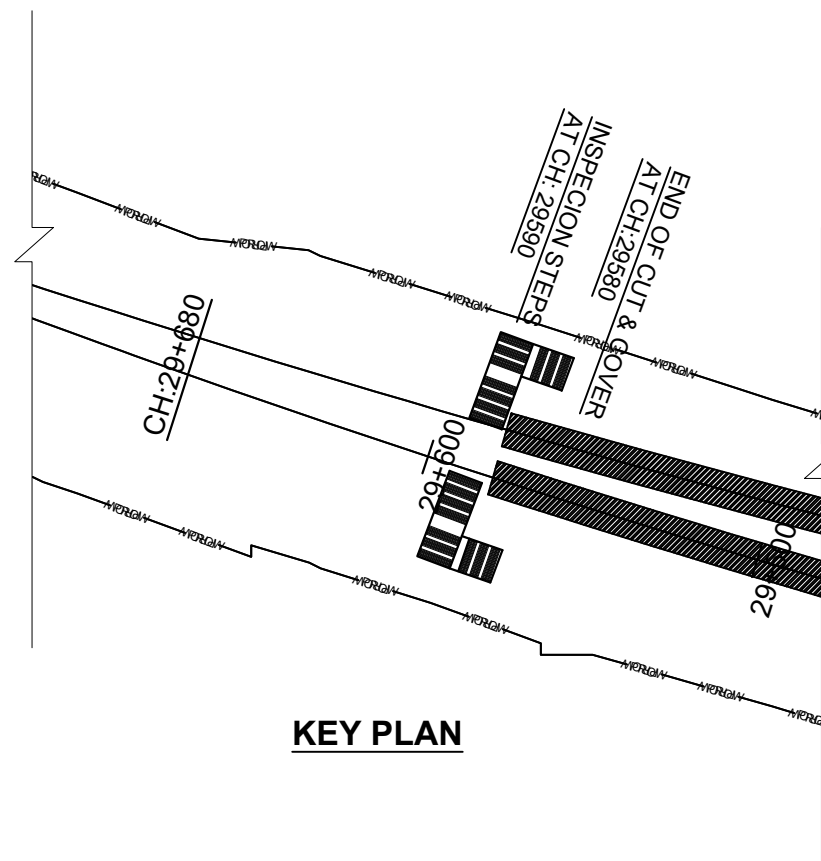

KEY PLAN

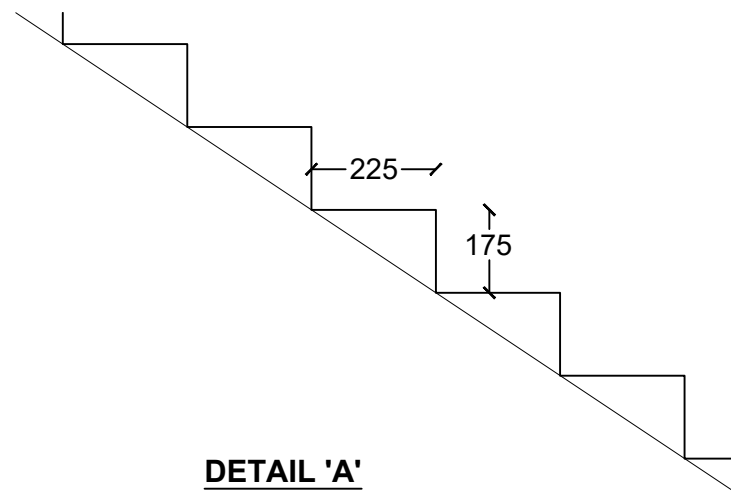

DETAIL 'A'

PROJECT:
HARYANA ORBITAL RAIL CORRIDOR
CONNECTING PALWAL TO SONIPAT BYPASSING DELHI
AREA BY LINKING ASAOOTI-PATLI-SULTANPUR-ASAUDAH BY
NEW ELECTRIFIED BG DOUBLE LINE

CLIENT:
HARYANA RAIL INFRASTRUCTURE
DEVELOPMENT CORPORATION LIMITED.

CONSULTANT:
GENERAL CONSULTANT FOR
HARYANA ORBITAL RAIL CORRIDOR
RITES Limited in consortium with SMEC International Pty. Ltd.



TITLE: Conceptual sketch for details of
inspection steps from
cutting in formation to ground

SKETCH NO. GC-HRIDC-C4-SK-TUNNEL-002_A0 **SHEET NO.**

SCALE : AS SHOWN **ISSUE DATE** 09.01.2023 **REVISED DATE**

GC/HORC		HRIDC	
NAME / DESIGNATION	SIGN	NAME / DESIGNATION	SIGN
CHAHATEY RAM PD	<i>Chahatey Ram</i>	SHIV OM DWIVEDI CPM/HRIDC	<i>Shiv</i>
SUDHIR AGRAWAL DPD/CIVIL	<i>Sudhir</i>	RAJU SOLANKI DGM/CIVIL/SOUTH	<i>Raju</i>
REETU PATIAL CDE/ CIVIL	<i>Reetu</i>		

General Electrical Services Drawings

- NOTES:
1. SUBSTATION TO BE PROVIDED WITH VENTILATION SYSTEM TO CATER LOAD OF EQUIPMENTS.
 2. BAFFLE WALL HEIGHT SHALL COVER TOP OF THE TRANSFORMER LEVEL.
 3. THE CABLE LAYING ARRANGEMENT INSIDE THE TRENCHES SHALL BE LAID AS PER SITE CONDITION.
 4. THE BENDING RADIUS OF HT/LT CABLES SHALL CONFIRM TO IS-STANDARDS.

THIS DRAWING SHALL BE READ IN CONJUNCTION WITH TENDER SPECIFICATION

PROJECT:
HARYANA ORBITAL RAIL CORRIDOR
 CONNECTING PALWAL TO SONIPAT BYPASSING DELHI AREA BY LINKING ASAOTI-PATLI-SULTANPUR-ASAUDAH BY NEW ELECTRIFIED BG DOUBLE LINE

CLIENT:
 **HARYANA RAIL INFRASTRUCTURE DEVELOPMENT CORPORATION LIMITED.**

CONSULTANT:
 **GENERAL CONSULTANT FOR HARYANA ORBITAL RAIL CORRIDOR**
 RITES Limited in consortium with SMEC International Pty. Ltd.





TITLE:- **INDICATIVE LAYOUT PLAN OF SUB-STATION 11/0.433kV NEAR UTILITY SHAFT**

DRG. NO. **GC-HRIDC-C4-DRW-TTL-ELE-001_A2** SHEET NO. **1 OF 1**

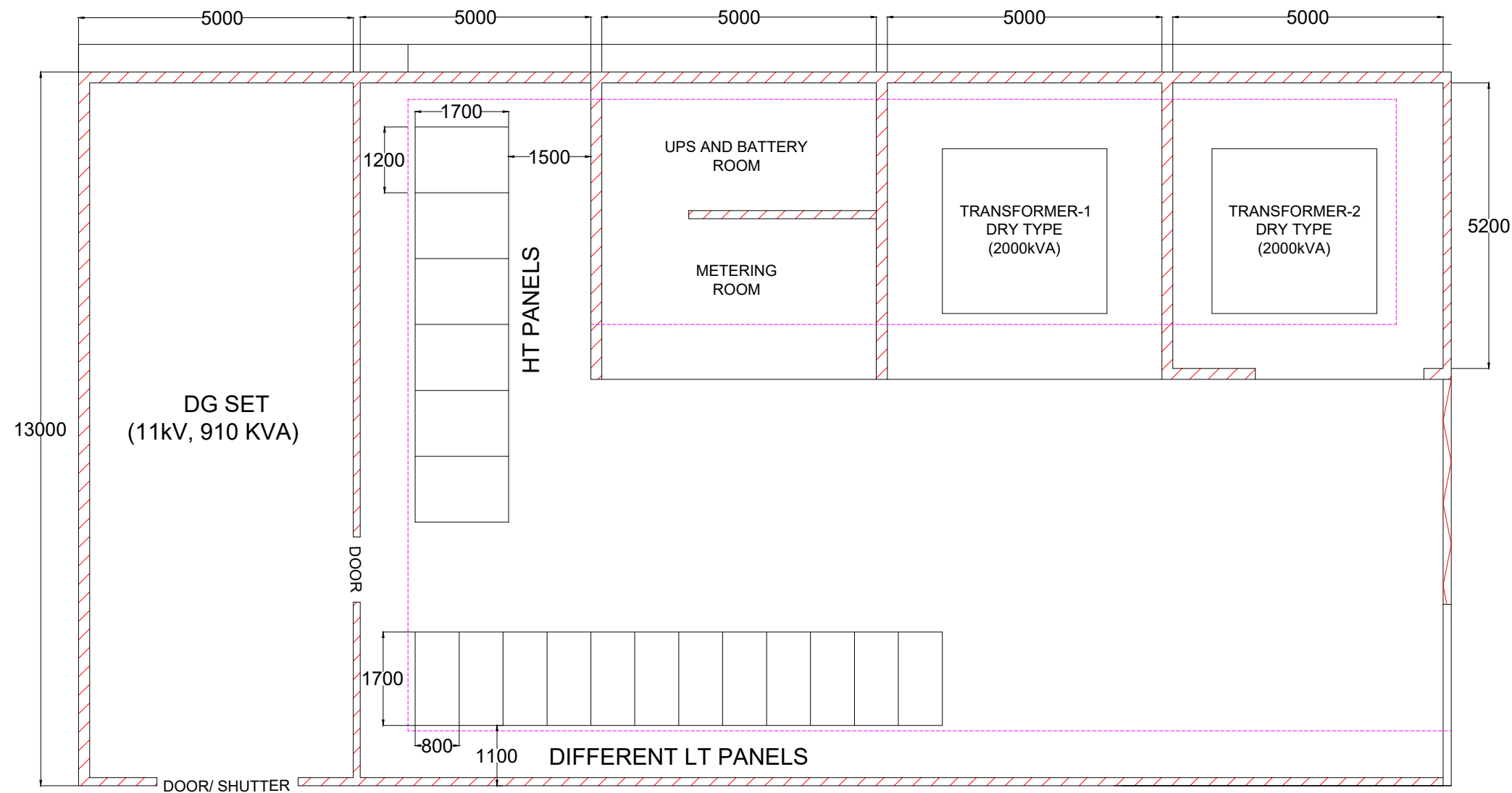
SCALE : **AS SHOWN** ISSUE DATE **07.11.2022** REVISED DATE **09.01.2023**



INDICATIVE LAYOUT PLAN OF SUB-STATION (SS1) NEAR CONSTRUCTION CUM UTILITY SHAFT OF TUNNEL 11/0.443kV(25M X 13M) FOR REFERENCE PURPOSE ONLY

GC/HORC		HRIDC	
NAME / DEGINATION	SIGN	NAME / DEGINATION	SIGN
CHAHATEY RAM PD		SHIV OM DWIVEDI CPM/HRIDC	
A.S. JANGHU CRE/Elect.		MENDLEEF KATIYAR AM/Elect.	
STIPHEN SAHOO ARE/Elect.			

NOTES:

1. SUBSTATION TO BE PROVIDED WITH VENTILATION SYSTEM TO CATER LOAD OF EQUIPMENTS.
2. BAFFLE WALL HEIGHT SHALL COVER TOP OF THE TRANSFORMER LEVEL.
3. THE CABLE LAYING ARRANGEMENT INSIDE THE TRENCHES SHALL BE LAID AS PER SITE CONDITION.
4. THE BENDING RADIUS OF HT/LT CABLES SHALL CONFIRM TO IS-STANDARDS.

THIS DRAWING SHALL BE READ IN CONJUNCTION WITH TENDER SPECIFICATION

PROJECT:
 HARYANA ORBITAL RAIL CORRIDOR
 CONNECTING PALWAL TO SONIPAT BYPASSING DELHI AREA BY LINKING ASAOTI-PATLI-SULTANPUR-ASAUDAH BY NEW ELECTRIFIED BG DOUBLE LINE

CLIENT:
 HARYANA RAIL INFRASTRUCTURE DEVELOPMENT CORPORATION LIMITED.

CONSULTANT:
 GENERAL CONSULTANT FOR HARYANA ORBITAL RAIL CORRIDOR
 RITES Limited in consortium with SMEC International Pty. Ltd.





TITLE:- INDICATIVE LAYOUT PLAN OF SUB-STATION 11/0.433kV

DRG. NO. GC-HRIDC-C4-DRW-TTL-ELE-002_A2 **SHEET NO.** 1 OF 1

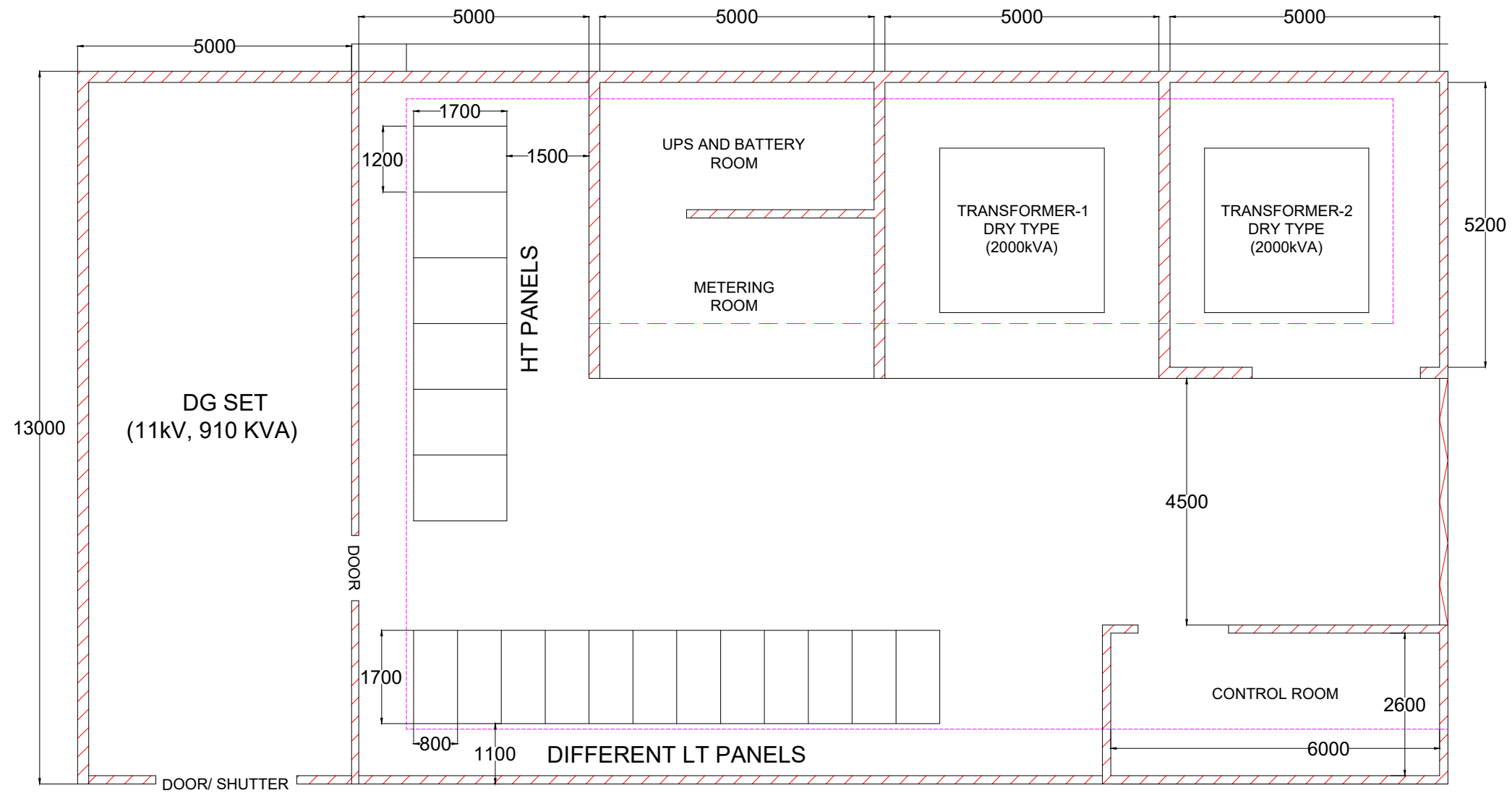
SCALE : AS SHOWN **ISSUE DATE** 07.11.2022 **REVISED DATE** 09.01.2023



INDICATIVE LAYOUT PLAN OF SUB-STATION (SS2) NEAR SONIPAT END PORTAL OF TUNNEL 11/0.443kV (25M X 13M) FOR REFERENCE PURPOSE ONLY

GC/HORC		HRIDC	
NAME / DEGINATION	SIGN	NAME / DEGINATION	SIGN
CHAHATEY RAM PD		SHIV OM DWIVEDI CPM/HRIDC	
A.S. JANGHU CRE/Elect.		MENDLEEF KATIYAR AM/Elect.	
STIPHEN SAHOO ARE/Elect.			

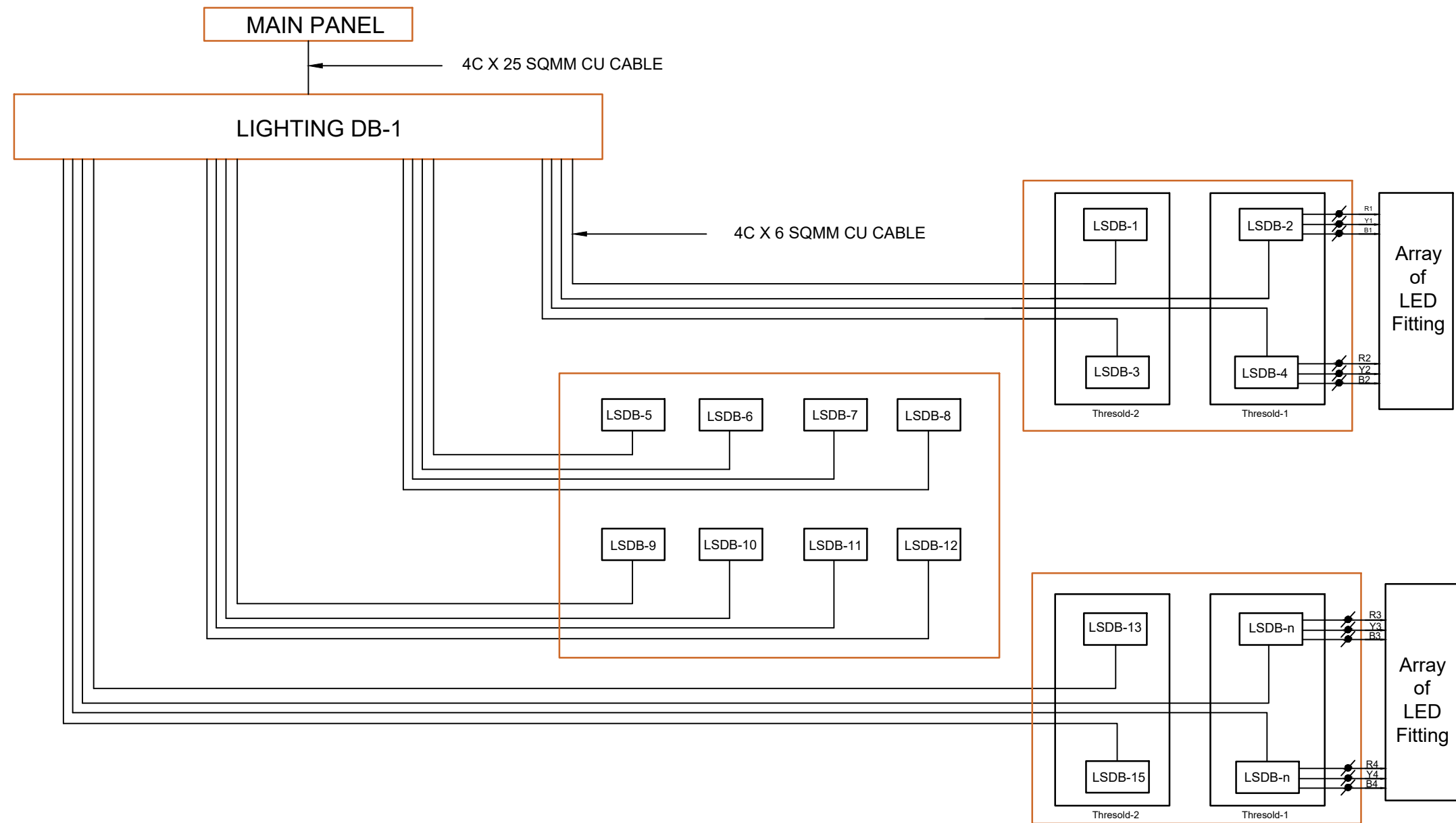

**POWER SUPPLY FOR LIGHTING
ARRANGEMENT AT TUNNEL-1 & TUNNEL-2**

PROJECT:
HARYANA ORBITAL RAIL CORRIDOR
CONNECTING PALWAL TO SONIPAT BYPASSING DELHI
AREA BY LINKING ASAOTI-PATLI-SULTANPUR-ASAUDAH BY
NEW ELECTRIFIED BG DOUBLE LINE

CLIENT:
HARYANA RAIL INFRASTRUCTURE
DEVELOPMENT CORPORATION LIMITED

CONSULTANT:
GENERAL CONSULTANT FOR
HARYANA ORBITAL RAIL CORRIDOR
RITES Limited in consortium with SMEC International Pty. Ltd.



TITLE:- POWER SUPPLY FOR LIGHTING
ARRANGEMENT (INDICATIVE)

GC/HORC		HRIDC	
NAME / DESIGNATION	SIGN	NAME / DESIGNATION	SIGN
CHAHATEY RAM PD	<i>Chahatey Ram</i>	SHIV OM DWIVEDI CPM/HRIDC	
A.S. JANGHU CRE/Elect.	<i>A.S. Janghu</i>	MENDLEEF KATIYAR AM/Elect.	
STIPHEN SAHOO ARE/Elect.	<i>Stephen Sahoo</i>		

DRG. NO. GC-HRIDC-C4-DRW-TTL-ELE-003_A2	SHEET NO. 1 OF 1
SCALE : AS SHOWN	ISSUE DATE 07.11.2022
	REVISED DATE 09.01.2023

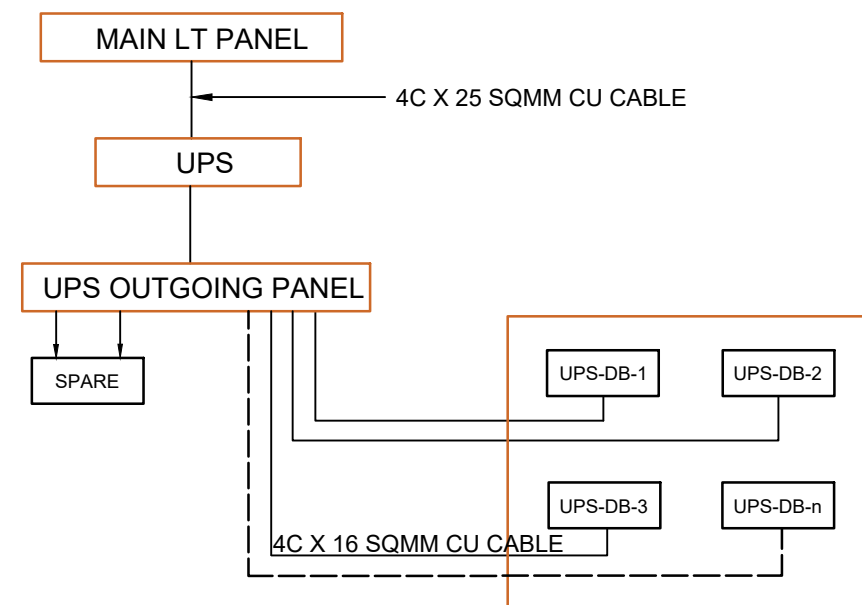

POWER SUPPLY ARRANGEMENT FOR UPS SUPPLY AT SS-1 IN BOTH TUNNELS

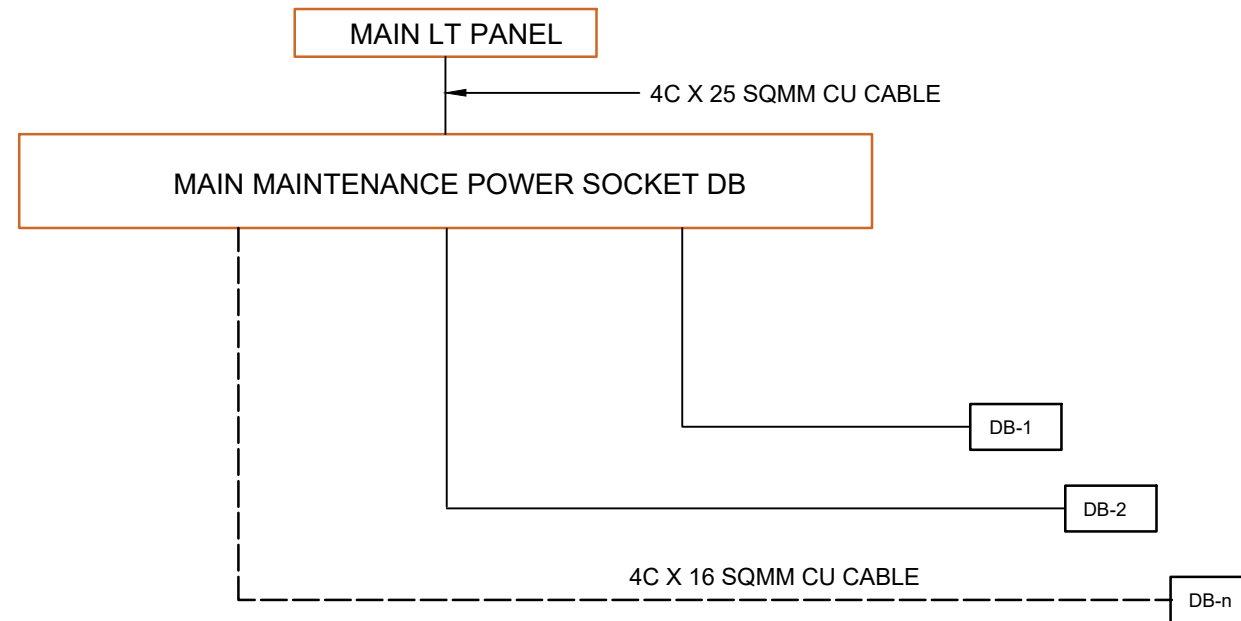

MAINTENANCE POWER SOCKET (1&3 PHASE) DB DIAGRAM AT TUNNEL -1

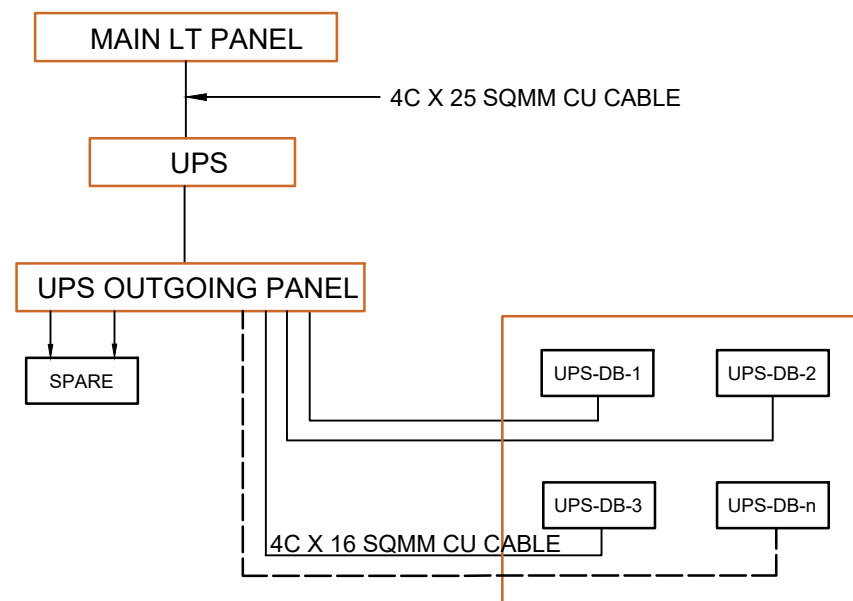

POWER SUPPLY ARRANGEMENT OF UPS MAIN PANEL AT SS-2 IN BOTH TUNNELS

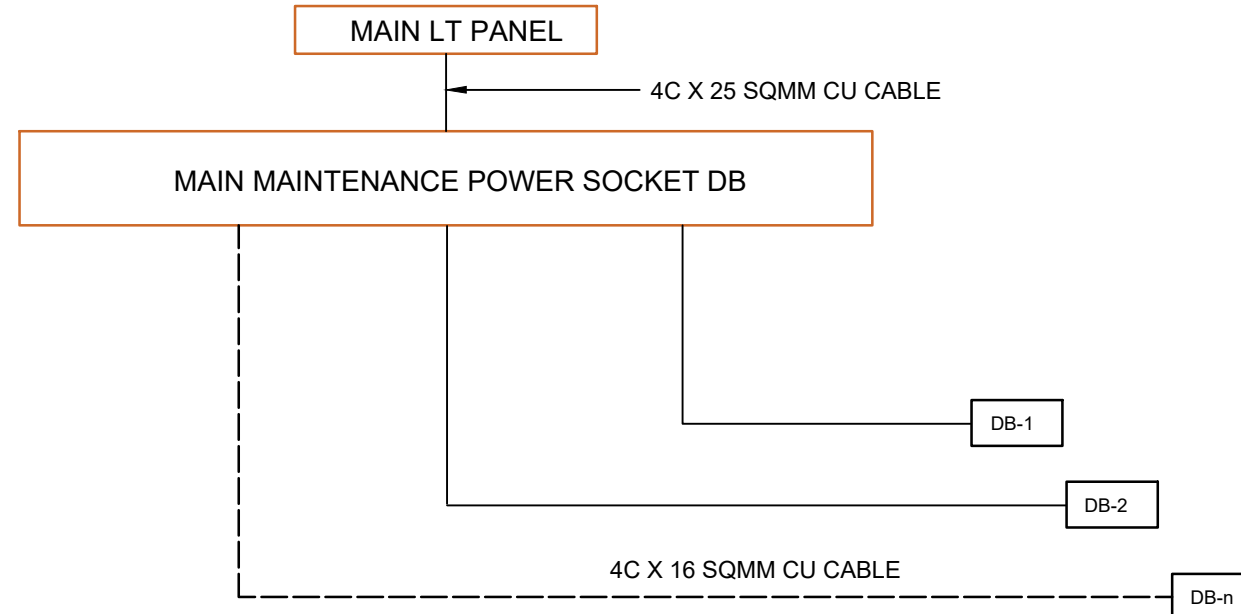

MAINTENANCE POWER SOCKET (1&3 PHASE) DB DIAGRAM AT TUNNEL -2

PROJECT:
HARYANA ORBITAL RAIL CORRIDOR
CONNECTING PALWAL TO SONIPAT BYPASSING DELHI AREA BY LINKING ASAOTI-PATLI-SULTANPUR-ASAUDAH BY NEW ELECTRIFIED BG DOUBLE LINE

CLIENT:
HARYANA RAIL INFRASTRUCTURE DEVELOPMENT CORPORATION LIMITED

CONSULTANT:
GENERAL CONSULTANT FOR HARYANA ORBITAL RAIL CORRIDOR
RITES Limited in consortium with SMEC International Pty. Ltd.



TITLE:- POWER SUPPLY ARRANGEMENT FOR EMERGENCY AND MAINTENANCE POWER SOCKET DIAGRAM (INDICATIVE)

GC/HORC		HRIDC	
NAME / DESIGNATION	SIGN	NAME / DESIGNATION	SIGN
CHAHATEY RAM PD	<i>Chahatey Ram</i>	SHIV OM DWIVEDI CPM/HRIDC	
A.S. JANGHU CRE/Elect.	<i>A.S. Janghu</i>	MENDLEEF KATIYAR AM/Elect.	
STIPHEN SAHOO ARE/Elect.	<i>Stephen Sahoo</i>		

DRG. NO. GC-HRIDC-C4-DRW-TTL-ELE-004_A2 **SHEET NO.** 1 OF 1

SCALE : AS SHOWN **ISSUE DATE** 07.11.2022 **REVISED DATE** 09.01.2023

SINGLE LINE DIAGRAM OF HT POWER SUPPLY SYSTEM IN TUNNEL

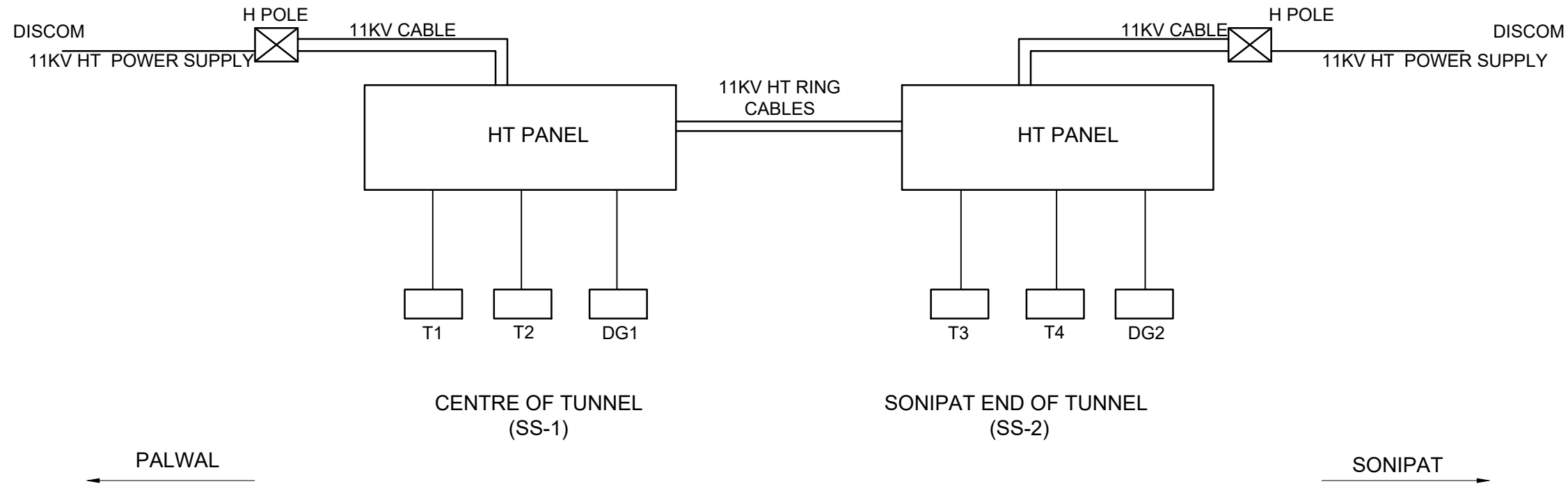

- NOTES:**
- 11 kV power supply from DISCOM may be by overhead line or cable.
 - Cable bending radius to be maintained as per IS-standards.

THIS DRAWING SHALL BE READ IN CONJUNCTION WITH TENDER SPECIFICATION

PROJECT:
HARYANA ORBITAL RAIL CORRIDOR
 CONNECTING PALWAL TO SONIPAT BYPASSING DELHI AREA BY LINKING ASAOTI-PATLI-SULTANPUR-ASAUDAH BY NEW ELECTRIFIED BG DOUBLE LINE

CLIENT:
 **HARYANA RAIL INFRASTRUCTURE DEVELOPMENT CORPORATION LIMITED**

CONSULTANT:
 **GENERAL CONSULTANT FOR HARYANA ORBITAL RAIL CORRIDOR**
 RITES Limited in consortium with SMEC International Pty. Ltd.



TITLE:-
 SINGLE LINE DIAGRAM OF HT SYSTEM IN TUNNEL (INDICATIVE)

GC/HORC		HRIDC	
NAME / DESIGNATION	SIGN	NAME / DESIGNATION	SIGN
CHAHATEY RAM PD		SHIV OM DWIVEDI CPM/HRIDC	
A.S. JANGHU CRE/Elect.		MENDLEEF KATIYAR AM/Elect.	
STIPHEN SAHOO ARE/Elect.			

DRG. NO.
 GC-HRIDC-C4-DRW-TTL-ELE-005_A1

SHEET NO.
 1 OF 1

SCALE : AS SHOWN

ISSUE DATE	09.01.2023
REVISED DATE	

Land Area for Tunnel

Land Area Taken for Execution of Tunnel & Shafts

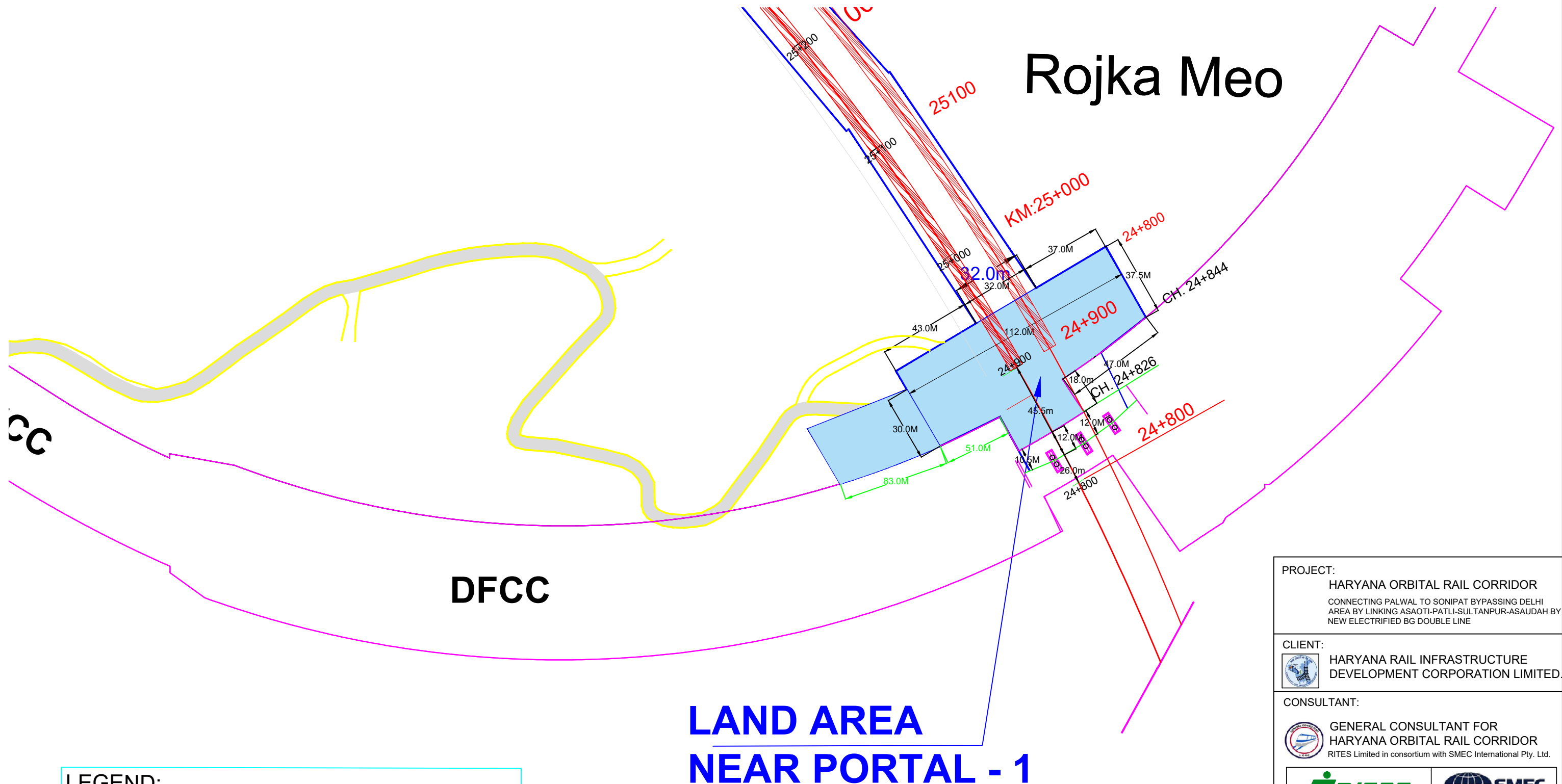
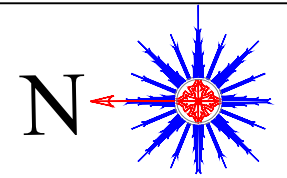

LEGEND:
 LAND WILL BE HANDED OVER IN D+7 DAYS
D- COMMENCEMENT DATE





LAND AREA NEAR PORTAL - 1

PROJECT:
 HARYANA ORBITAL RAIL CORRIDOR
 CONNECTING PALWAL TO SONIPAT BYPASSING DELHI
 AREA BY LINKING ASAOTI-PATLI-SULTANPUR-ASAUDAH BY
 NEW ELECTRIFIED BG DOUBLE LINE

CLIENT:
 HARYANA RAIL INFRASTRUCTURE
 DEVELOPMENT CORPORATION LIMITED

CONSULTANT:
 GENERAL CONSULTANT FOR
 HARYANA ORBITAL RAIL CORRIDOR
 RITES Limited in consortium with SMEC International Pty. Ltd.



GC/HORC		HRIDC	
NAME / DESIGNATION	SIGN	NAME / DESIGNATION	SIGN
CHAHATEY RAM PD		SHIV OM DWIVEDI CPM/HRIDC	
REETU PATIAL CDE/ CIVIL		RAJU SOLANKI DGM/CIVIL/SOUTH	

TITLE:-
 LAND AREA NEAR
 PORTAL-1

SKETCH NO. HRIDC-C4-SK-LANDPLAN-001_A1 SHEET NO.

SCALE : AS SHOWN ISSUE DATE 03.01.2023 REVISED DATE 10.01.2023

PERMANENT VENTILATION SHAFT 3 & 4 CH. 27+680 M

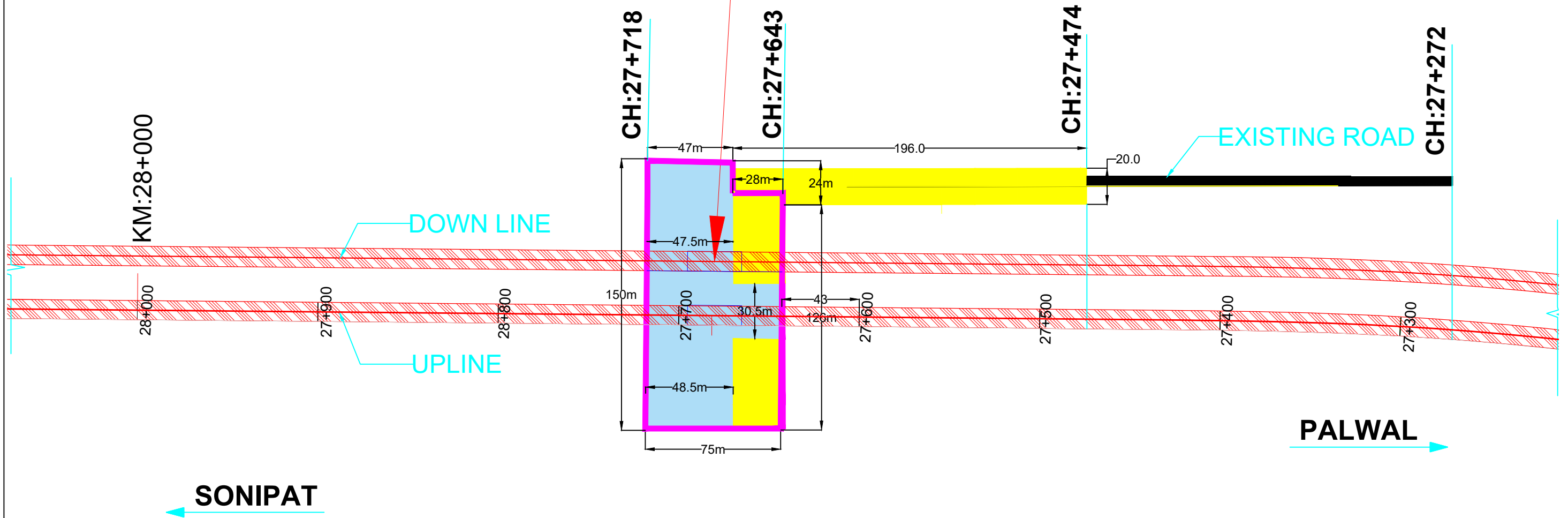

SONIPAT ←

→ **PALWAL**

LEGEND:

LAND WILL BE HANDED OVER IN D+7 DAYS

LAND WILL BE HANDED OVER IN D+90 DAYS

D- COMMENCEMENT DATE

PROJECT:
HARYANA ORBITAL RAIL CORRIDOR
CONNECTING PALWAL TO SONIPAT BYPASSING DELHI
AREA BY LINKING ASAOTI-PATLI-SULTANPUR-ASAUDAH BY
NEW ELECTRIFIED BG DOUBLE LINE

CLIENT:
HARYANA RAIL INFRASTRUCTURE
DEVELOPMENT CORPORATION LIMITED

CONSULTANT:
GENERAL CONSULTANT FOR
HARYANA ORBITAL RAIL CORRIDOR
RITES Limited in consortium with SMEC International Pty. Ltd.



TITLE:-
LAND AREA NEAR PERMANENT
VENTILATION SHAFT 1 & 2

GC/HORC		HRIDC	
NAME / DESIGNATION	SIGN	NAME / DESIGNATION	SIGN
CHAHATEY RAM PD	<i>Chahatey Ram</i>	SHIV OM DWIVEDI CPM/HRIDC	<i>Shiv Om Dwivedi</i>
REETU PATIAL CDE/ CIVIL	<i>Reetu Patial</i>	RAJU SOLANKI DGM/CIVIL/SOUTH	<i>Raju Solanki</i>

SKETCH NO. HRIDC-C4-SK-LANDPLAN-002 A1	SHEET NO.
SCALE : AS SHOWN	ISSUE DATE 03.01.2023
	REVISED DATE 10.01.2023

**CONSTRUCTION CUM
UTILITY SHAFT
CH. 26+950 M**

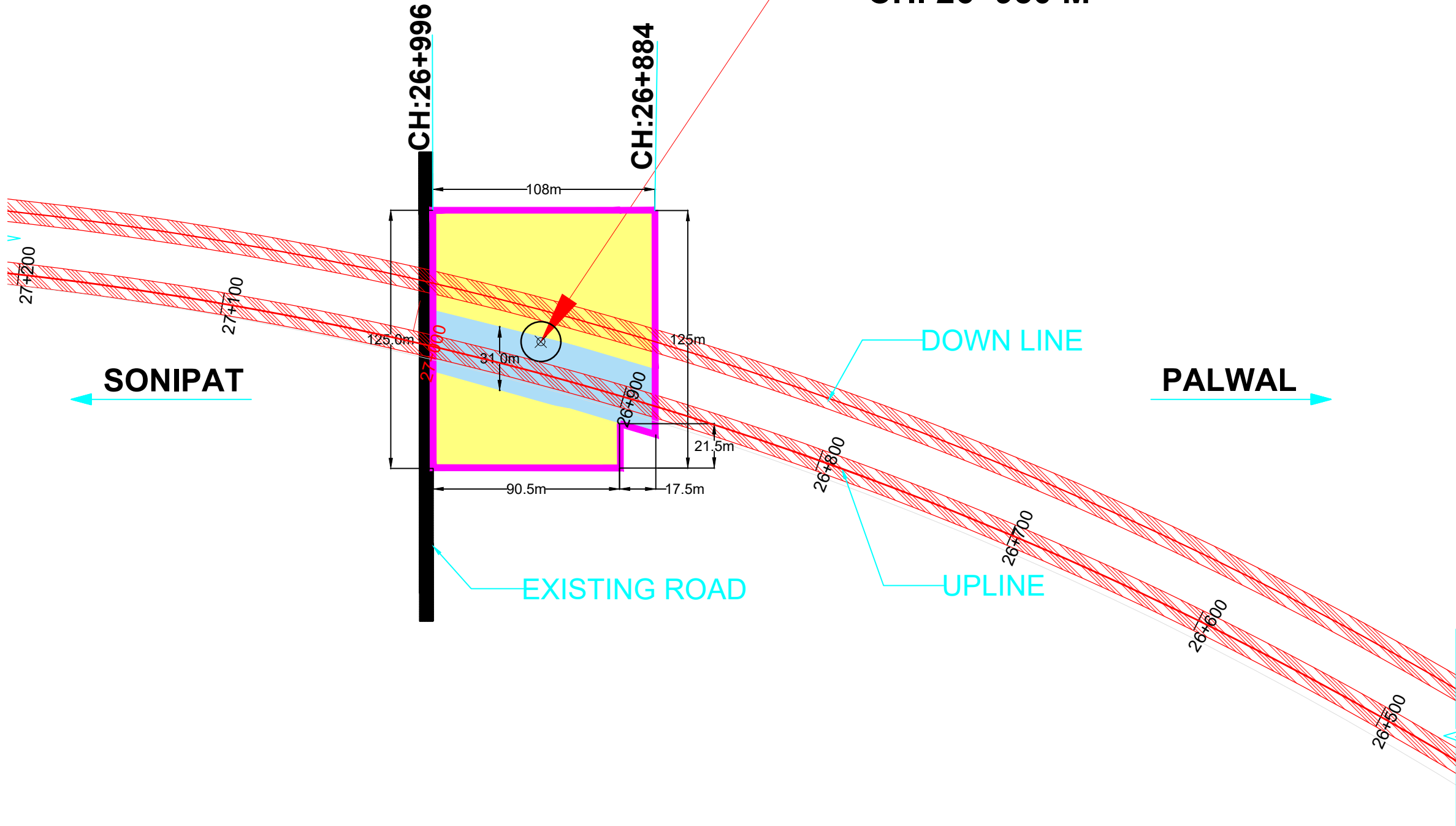

LEGEND:

LAND WILL BE HANDED OVER IN D+7 DAYS

LAND WILL BE HANDED OVER IN D+90 DAYS

D- COMMENCEMENT DATE

PROJECT:
HARYANA ORBITAL RAIL CORRIDOR
CONNECTING PALWAL TO SONIPAT BYPASSING DELHI
AREA BY LINKING ASAOTI-PATLI-SULTANPUR-ASAUDAH BY
NEW ELECTRIFIED BG DOUBLE LINE

CLIENT:
HARYANA RAIL INFRASTRUCTURE
DEVELOPMENT CORPORATION LIMITED.

CONSULTANT:
GENERAL CONSULTANT FOR
HARYANA ORBITAL RAIL CORRIDOR
RITES Limited in consortium with SMEC International Pty. Ltd.



TITLE:-
LAND AREA NEAR
CONSTRUCTION CUM UTILITY SHAFT

SKETCH NO.
HRIDC-C4-SK-LANDPLAN-003_A1

SHEET NO.

SCALE : AS SHOWN

ISSUE DATE: 03.01.2023

REVISED DATE: 10.01.2023

GC/HORC		HRIDC	
NAME / DESIGNATION	SIGN	NAME / DESIGNATION	SIGN
CHAHATEY RAM PD	<i>Chahatey Ram</i>	SHIV OM DWIVEDI CPM/HRIDC	<i>Shiv</i>
REETU PATIAL CDE/ CIVIL	<i>Reetu</i>	RAJU SOLANKI DGM/CIVIL/SOUTH	<i>Raju</i>

**PERMANENT VENTILATION
SHAFT 1 & 2
CH. 26+080 M**

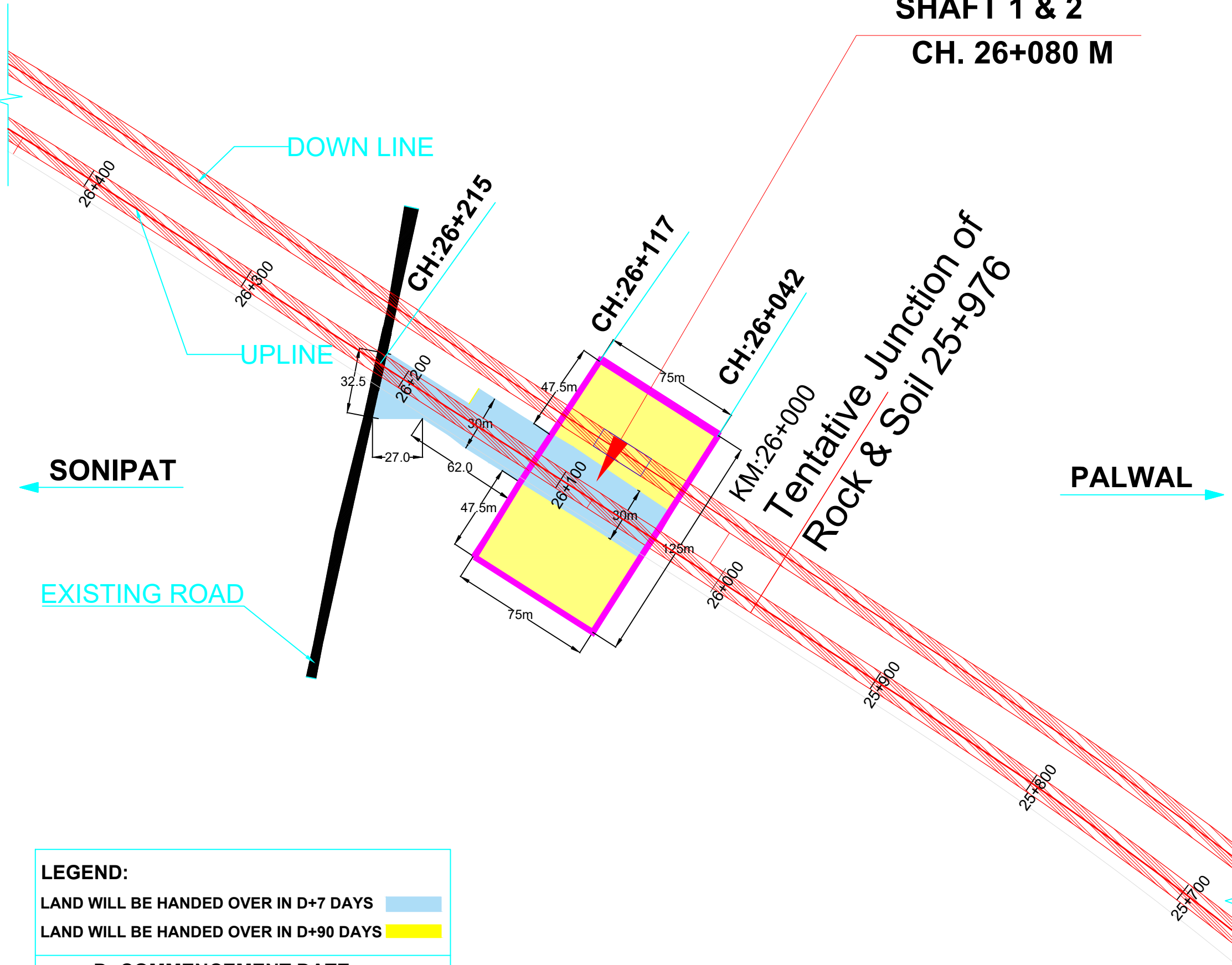

LEGEND:
 LAND WILL BE HANDED OVER IN D+7 DAYS
 LAND WILL BE HANDED OVER IN D+90 DAYS
D- COMMENCEMENT DATE

PROJECT:
 HARYANA ORBITAL RAIL CORRIDOR
 CONNECTING PALWAL TO SONIPAT BYPASSING DELHI
 AREA BY LINKING ASAOTI-PATLI-SULTANPUR-ASAUDAH BY
 NEW ELECTRIFIED BG DOUBLE LINE

CLIENT:
 HARYANA RAIL INFRASTRUCTURE
 DEVELOPMENT CORPORATION LIMITED

CONSULTANT:
 GENERAL CONSULTANT FOR
 HARYANA ORBITAL RAIL CORRIDOR
 RITES Limited in consortium with SMEC International Pty. Ltd.



TITLE:-
 LAND AREA NEAR PERMANENT
 VENTILATION SHAFT 3 & 4

GC/HORC		HRIDC	
NAME / DESIGNATION	SIGN	NAME / DESIGNATION	SIGN
CHAHATEY RAM PD		SHIV OM DWIVEDI CPM/HRIDC	
REETU PATIAL CDE/ CIVIL		RAJU SOLANKI DGM/CIVIL/SOUTH	

SKETCH NO. HRIDC-C4-SK-LANDPLAN-004_A1	SHEET NO.
SCALE : AS SHOWN	ISSUE DATE 03.01.2023
	REVISED DATE 10.01.2023

LAND DETAILS FROM CH.28+341M TO 29+680M

LAND FROM CH. 28341M TO 29000M

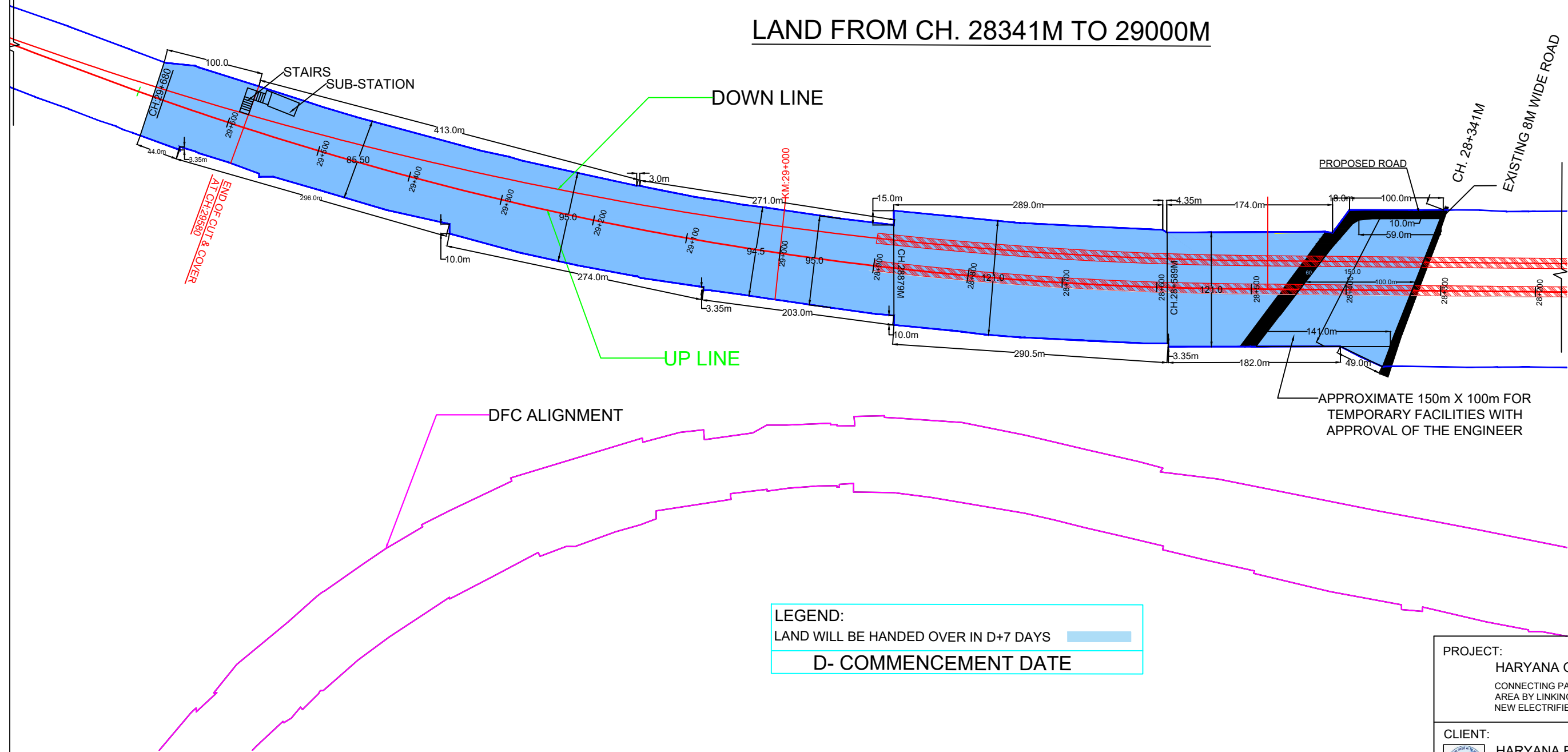





LEGEND:
 LAND WILL BE HANDED OVER IN D+7 DAYS
D- COMMENCEMENT DATE

PROJECT:
 HARYANA ORBITAL RAIL CORRIDOR
 CONNECTING PALWAL TO SONIPAT BYPASSING DELHI AREA BY LINKING ASAOTI-PATLI-SULTANPUR-ASAUDAH BY NEW ELECTRIFIED BG DOUBLE LINE

CLIENT:
 HARYANA RAIL INFRASTRUCTURE DEVELOPMENT CORPORATION LIMITED.

CONSULTANT:
 GENERAL CONSULTANT FOR HARYANA ORBITAL RAIL CORRIDOR
 RITES Limited in consortium with SMEC International Pty. Ltd.

GC/HORC		HRDC	
NAME / DESIGNATION	SIGN	NAME / DESIGNATION	SIGN
CHAHATEY RAM PD		SHIV OM DWIVEDI CPM/HRDC	
		RAJU SOLANKI DGM/CIVIL/SOUTH	
REETU PATIAL CDE/ CIVIL			

TITLE:-
 LAND DETAILS FROM
 CH: 28341m TO 29680m

SKETCH NO. HRDC-C4-SK-LANDPLAN-005_A1	SHEET NO.
SCALE : AS SHOWN	ISSUE DATE 03.01.2023
	REVISED DATE 10.01.2023

Tender No. HORC/HRIDC/C-4/2022
Attachment 9
to
Corrigendum No. 3

**Part 2, Section VII-8: Employer's
Requirements-Tender Drawings and
documents**

Section VII-8B: Tender documents

6. Geotechnical Investigation Report

Report No. SR NO. : 544_21-22

**Table 4.5: Safe Load Carrying Capacity of normal bored cast in-situ RCC Pile
in Soil” of Geotechnical Investigation Reports No. SR NO. : 544_21-22**

**Table 4.5: Safe Load Carrying Capacity of normal bored cast in-situ RCC Pile in Soil
{Old Ch.-13+787 (New Ch.-14+472) to Old Ch. 16+231 (New Ch.-16+917)}**

Chainage Old	Chainage New	BH. No.	Diameter of Pile (m)	Length of piles below cut-off (m)	Cut-off level below EGL (m)	Safe load carrying capacity of single pile (T)		
						In compression	In uplift	In Lateral
								Fixed Head
13+787	14+472	BH-A1	1.0	20.0	2.0	168.0	149.0	15.4
				22.0		182.0	165.0	
				24.0		197.0	181.0	
				26.0		222.0	197.0	
				28.0		238.0	214.0	
				30.0		290.0	235.0	
			1.2	20.0		215.0	190.0	18.5
				22.0		233.0	211.0	
				24.0		252.0	232.0	
				26.0		285.0	253.0	
				28.0		305.0	275.0	
				30.0		376.0	301.0	
		BH-P1	1.0	20.0	2.0	123.0	104.0	5.3
				22.0		138.0	119.0	
				24.0		153.0	136.0	
				26.0		188.0	153.0	
				28.0		220.0	174.0	
				30.0		235.0	194.0	
			1.2	20.0		164.0	136.0	8.4
				22.0		182.0	156.0	
				24.0		201.0	178.0	
				26.0		248.0	200.0	
				28.0		272.0	226.0	
				30.0		309.0	252.0	
BH-A2	1.0	20.0	2.0	152.0	127.0	5.9		
		22.0		167.0	143.0			
		24.0		182.0	160.0			

Chainage Old	Chainage New	BH. No.	Diameter of Pile (m)	Length of piles below cut-off (m)	Cut-off level below EGL (m)	Safe load carrying capacity of single pile (T)		
						In compression	In uplift	In Lateral
								Fixed Head
				26.0		198.0	178.0	
				28.0		237.0	196.0	
				30.0		254.0	214.0	
13+787	14+472	BH-A2	1.2	20.0	2.0	198.0	164.0	8.7
				22.0		217.0	185.0	
				24.0		236.0	207.0	
				26.0		257.0	230.0	
				28.0		309.0	253.0	
				30.0		330.0	276.0	
15+441	16+127	BH-A1	1.0	20.0	2.0	158.0	134.0	9.6
				22.0		185.0	150.0	
				24.0		200.0	166.0	
			1.2	20.0		205.0	172.0	13.4
				22.0		241.0	193.0	
				24.0		260.0	214.0	
		BH-A2	1.0	20.0		163.0	136.0	13.2
				22.0		178.0	153.0	
				24.0		195.0	171.0	
			1.2	20.0		212.0	175.0	17.2
				22.0		231.0	197.0	
				24.0		252.0	220.0	
16+042	16+727	BH-A1	1.0	20.0	2.0	161.0	140.0	13.3
				22.0		181.0	156.0	
				24.0		239.0	177.0	
			1.2	20.0		206.0	179.0	19.3
				22.0		232.0	200.0	
				24.0		312.0	226.0	
		BH-A2	1.0	20.0		164.0	128.0	9.4
				22.0		183.0	144.0	

Chainage Old	Chainage New	BH. No.	Diameter of Pile (m)	Length of piles below cut-off (m)	Cut-off level below EGL (m)	Safe load carrying capacity of single pile (T)		
						In compression	In uplift	In Lateral
								Fixed Head
			1.2	24.0		198.0	161.0	
				20.0		215.0	164.0	14.0
			22.0	234.0		185.0		
			24.0	257.0		207.0		
16+231	16+917	BH-A1	1.0	20.0	2.0	163.0	134.0	10.8
				22.0		184.0	155.0	
				24.0		237.0	178.0	
16+231	16+917	BH-A1	1.2	20.0	2.0	212.0	173.0	16.6
				22.0		241.0	202.0	
				24.0		341.0	235.0	
		BH-A2	1.0	2.0	20.0	160.0	136.0	15.1
					22.0	183.0	151.0	
					24.0	197.0	167.0	
		1.2	2.0	20.0	207.0	175.0	21.9	
				22.0	238.0	195.0		
				24.0	255.0	215.0		

Tender No. HORC/HRIDC/C-4/2022
Attachment 10
to
Corrigendum No. 3

Part 2, Section VII-8: Tender Drawings and Documents

Section VII-8B:

List of Documents

7. APPROVED MANUFACTURES/SUPPLIERS LIST/R1

APPROVED MANUFACTURES/SUPPLIERS LIST/R1

All materials and products shall conform to the Outline Construction Specification (OCS), BIS codes and other relevant codes etc. and shall be of make as approved by the Engineer.

The list of approved makes for products and materials is given below. Other equivalent manufacturers may also be considered with prior approval of the Engineer, if found conforming to all standards. Such requests should be made with all documents to the Engineer at least 45 days before the material is required and any order shall be placed only after receiving the written approval of the Engineer.

S. No.	Details of Materials/ Products	Manufacturer's Name
1.	Cement	ACC, Ultratech, Ambuja Cements, JK Lakshmi, JSW, JK Cement, Lafarge, <i>Shree Cement, Birla Cement, Grasim</i>
2.	Reinforcement Bars	<i>SAIL, JSW STEEL, TATASTEEL, RINL, JSPL</i>
3.	Epoxy	FOSROC, SIKA QUALCRETE, BASF, CICO, MC-BAUCHEMIE, MAPEI, CHRYSO, Huntsmen Advanced Materials
4.	Expansion Joints for Viaduct	Prequalified Manufacturers as per RDSO's latest approved list
5.	Admixtures	FOSROC, SIKA, MBT, MC-BAUCHEMIE, PIDILITE, CHRYSO, BASF, MAPEI, CICO
6.	Pile Integrity Testing	CIMEC, Geodynamics, AIMIL, CBRI, Pile Dynamic, CEGTH, FUGRO
7.	*Anchor Fastener	HILTI, FISHER, <i>BOSCH</i> , (Please note that ETA Certification is mandatory for using/supplying fasteners for load bearing structural members)
8.	Structural Steel	TATA, SAIL, ESSAR, <i>JSPL, JSW</i>
9.	Pre- stressing Strand (LRPC)	TATA SSL Ltd, USHA MARTIN
10.	*Pot/Elastomeric /Spherical Bearings	Prequalified Manufactures as per RDSO's latest approved list.
11.	HDPE Sheathing	<i>Rex Polyextrusion</i> , Gwalior Poly Pipes Ltd, Dynamic Prestress, JK Prestressing
12.	Formwork Release Agent	FOSROC, MC BAUCHEMIE, CICO, BASF, MAPEI, MBT, CHRYSO
13.	*Prestressing System	Freyssinet, BBR, VSL, Dynamic, Killick Nixon, Tensacciai (India Ltd.), JK Prestressing, Usha Martin, VSIL

S. No.	Details of Materials/ Products	Manufacturer's Name
14.	*Reinforcement Couplers	DEXTRA, , SANFIELD, SPLICETECH COUPLERS
15.	Hollow Sections, Pipes	Surya Pipes, Hi-Tech Pipes, JSW, JSPL, TATA.
16.	Drainage Pipes	Tirupati Plastomatics, Duraline, REX, STIPL
17.	Acrylic Textured Coatings	Spectrum, Surfa Nova, Jotun, Asian Paints, Berger, Hempel, DULUX
18.	Non Shrink Grout	FOSROC, Fairmate, BASF, SIKA, CICO, MBT, MC-Bauchemie, CHRYSO
19.	Bonding Coat	CICO, FOSROC, BASF, SIKA, MAPEI, MC-BAUCHEMIE, CHRYSO
20.	Polysuphide Sealant	CICO, PIDILITE, BASF, FOSROC, SIKA, CHRYSO
21.	*Steel Structural Fasteners	Sundram Fasteners, Nelson, <i>Dextra India</i> , Panchsheel, Pooja Forge (Please note that ETA Certification is mandatory for using/supplying fasteners for load bearing structural members)
22.	*Corrosion Protection Paints	Berger, Johnson Nicholson, Nerolac, Asian Paints, Akzo Nobel, Jotun
23.	Fire Resistant Paint	Akzo Nobel, PPG, Jotun
24.	Water stopper/ Bar	Greenstreak, Duron, Maruti, Kanta Rubber
25.	*Liquid Polymer membrane waterproofing	BASF, MAPEI , NINA, CICO, MYK Schomburg, Geo-Constech
26.	Curing Compound	FOSROC, CHRYSO, CICO, MC- BAUCHEMIE, MAPEI, MBT
27.	*Polycarbonate Sheets	Gallina Acroplus, Coxwell, Poly U, Fabic, Lexan, (SABIC Innovative Plastics), DANPALON, GE Plastics, VMI Plastics, Power Chem Plast
28.	Fly Ash	Thermal Plants, Ashcrete, Ultra Pozz, Star Pozz, Ashtech
29.	*Pre-Coated Profiled Metal Sheetings	TATA Blue Scope, Multicolor, Essar Steel, Bhushan Steel, Ispat Profile India
30.	Fly Ash Block/ AAC Block	Siporex, Ascolite, J.K. Laxmi, Ashtech
31.	Rock Bolts/Swellex Bolts	Geo Constech, DSI, Atlas Copco, FIREP International, Minova, Supanchor, Srons, Argentium
32.	Soft eye GFRP	Dextra, FIREP International, Minova, Hughes Brothers, Geo Constech
33.	Polymer	WALLGRIP, TRISHUL, Shubham Minerals, Goldy Minerals, GeoPolymer

S. No.	Details of Materials/ Products	Manufacturer's Name
34.	Welding electrodes	Ador welding Ltd.(Advani-Oerlikon),ESAB, D&H Welding Electrodes, Modi Arc
35.	Aluminium Sheets	Hindustan Aluminium, Jindal, Balco
36.	Vitrified Tiles	Asian Tiles, Somany, Johnson, Bell Ceramics, Kajaria, Simpolo
37.	Ceramic Tiles	NITCO, Orient, Regency Ceramics
38.	Wall Putty	JK White, Birla
39.	Flush Doors	Samrat, Kanchan, Prima Swastik, Kutty, Diamond
40.	Adhesives	Pidilite, Araldite, Toyo Ferrous Crete
41.	Plywood	Duroply, Century Plywood, Green Plywood, Kitply
42.	Veneers	Green Plywood, Century Plywood, Kitply
43.	FloatGlass/Toughened Glass/Insulated Glass/Laminated Glass	Saint Gobain, Modiguard, Tata Float, Float Glass, Asahi Float
44.	Heavy Duty Chequered Tiles	NITCO. Hindustan Tiles, Super Tiles & Marbles Pvt.Ltd.
45.	Heavy Duty Vitrified Tiles	Kajaria World
46.	Emulsion Paint	Asian Paints, Berger, Nerolac, Johnson & Nicholson, Dulux, ICI
47.	Synthetic Enamel	Asian Paints, Berger, Nerolac, Johnson & Nicholson, Dulux, ICI
48.	Paver Blocks	As approved by the Engineer
49.	Sanitary & Bath Fittings	Hindware, Parryware, Jaquar, HR & Johnson, Cera, , Somany, Asian Granito
50.	Aluminium doors & windows	Sehgal & Sehgal Industries
51.	Yellow Tactile Tiles	Palican
52.	SS Railing	The Cavalier, D Line India, DOORMAT, Panchal Enterprises, SS Enterprises
53.	Glass Mosaic Tiles	Mridul Enterprises, Krishna, Italia, Bissazza, Kenzai, Opio
54.	Granite Slabs & Tiles	As approved by the Engineer.
55.	Steel fibre	Precision, SIC, Berkert
56.	Seamless pipes	Maharashtra seamless, Srons, Argentium, Machino International
57.	Resin & cement	SIKA, Ashoka chemicals, Buildcon, Techno precision

S. No.	Details of Materials/ Products	Manufacturer's Name
	capsules	
58.	Instrumentation (load cells, pressure cells, Bi-reflex targets, MBPX, stress cells, extensometers, inclinometer, piezometer, strain cell etc.)	Encardio-Rite, PMT, Systel

NOTE: For the categories marked as *, the enclosed undertaking performa should be duly filled and signed by authorized representatives of concerned agencies.

UNDERTAKING

Name of Contract:

Date of start of work:

1983 Category of work:

Date of completion of work:

This is to certify that work of (Category to be mentioned) at

..... (Location) of the contract.....(Name of contract) has been executed/completed in accordance with the manufacturer's/supplier's specifications and as per the approved method statement.

The work has been jointly inspected by authorised representative of(Manufacturer/supplier), (Executing agency) &..... (Contractor) during its execution and all non-conformities observed during inspection have been complied to achieve the best industry standards.

The undersigned take full responsibility of the overall adequacy, accuracy, effectiveness & warranty (upto design life) of the completed work as per the provision of the contract..... (Contract number) and Outline Construction Specifications of the Part 2- Employer's Requirements.

(Stamp and Signature)

**Manufacturer
Representative**

**(Stamp and
Signature)**

**Executing agency
Representative**

**(Stamp and
Signature)**

**Contractor
Representative**

Tender No. HORC/HRIDC/C-4/2022

Attachment 11 to Corrigendum No. 3

Part 2, Section VII-9: Employer's Requirements-Appendices

Appendix- 10, Construction & Site Managements,

**Sub-Clause=10.19, Site Office and Resting Accommodation for the Employer/
Engineer**

10.19 SITE OFFICE AND RESTING ACCOMMODATION FOR THE EMPLOYER/ENGINEER

- 10.19.1** One Site *office accommodation* (total area 500 sqm) for the Engineer's & Employer's Staff including Meeting Room shall be provided. *In addition, one resting accommodation of about 300 sqm area consisting of four suites with attached toilet facilities, drawing, dining, kitchen and other incidental facilities along with full furnishing shall also be provided by the Contractor. The land for the above accommodation shall be provided by the Employer free of cost. The Contractor shall provide one cook and one housekeeping staff round the clock at the resting accommodation. In office, one pantry staff and one housekeeping shall be provided round the clock. The Contractor shall be responsible for the security, safety, Housekeeping, Water supply, Electricity supply, sewerage/drainage and waste disposal of the Site office and resting accommodation round the clock.*
- 10.19.2** Offices shall be accessible only from a corridor within the building. The corridor and reception area shall be provided with an external double door. The office will be provided with electronic surveillance system as approved by Engineer.
- 10.19.3** Materials for the construction shall be new, robust and durable. The building shall be weather proof, vermin proof, well insulated thermally and acoustically. Internal walls shall be soundproof. Electrical power/lighting, shall be provided to each room, including air-conditioning and heating to maintain the internal temperature within the range of 20 to 24 degrees Celsius at all times.
- 10.19.4** Internal doors shall be flush, fitted with door closers, mortice locks with keys and lever handles.
- 10.19.5** External doors shall be a pair of solid core doors, external quality, hung on heavy duty hinges, one leaf fitted with barrel bolts top and bottom and the other leaf fitted with a Yale or similar lock.
- 10.19.6** Windows, of area not less than 10% of the floor area, shall be provided to all rooms, securely barred, fitted with blinds and having opening sections fitted with locks and mosquito screens.
- 10.19.7** The building shall be provided with a continuous water supply and drainage to Kitchen, Washroom and Toilets. The Toilets shall be equipped with low level suites and be adequately ventilated through the ceiling.
- 10.19.8** The Kitchen shall be fitted out with a 2-drainer stainless steel double sink unit, worktop with cupboards under, tiling above the sink and worktop and wall mounted cupboards.
- 10.19.9** Fire and Safety regulations shall be complied with and firefighting equipment shall be provided in accordance with the statutory requirements.
- 10.19.10** The Contractor shall provide, erect, and maintain appropriate name boards as specified, for each of the offices. The working shall be agreed with the Engineer.
- 10.19.11** The Contractors shall provide the following new furniture and equipment for the exclusive use of the Engineer's/Employer's Staff:

Table A: Equipment for the exclusive use of the Engineer's/Employer's Staff at Site Office

No.	Item	Nos.
Furniture		
1	Sofa set	2
2	Desk with side drawers.	10
3	Swivel Office Chair with arm rests	8
4	Swivel Office chair without arm rests.	10
5	Typist Chair	12
6	Visitor's Chair	1
7	3-Shelf Bookcase	2
8	4-Drawer Lockable Filing Cabinet	5
9	Lockable Cupboard 2m high, with shelves.	10
10	Table	3
11	Bookshelf 2000x850x350mm (5 shelves)	5
12	White Board 2000x1000mm	4
13	TV set LED Screen	1
14	Projector Screen for Meeting Room (72"x72")	1
15	Wall Clock	2
16	Coffee Machine	1
17	Cupboard Table height	1
18	Printer cum scanner cum Photocopier A4/A3 (Canon, HP) capable of reduction	2
19	Wifi internet connectivity with <i>at least</i> 100mbps	1
20	Desktop Computers (Dell, HP) with following configurations:	4

No.	Item	Nos.
	Processor- i5 12 th GEN Intel; Operating System- Windows 11 Professional 64 bit; Video Card- intel; Memory- 16 GB Ram, DDR4; Hard Drive-1TB. SSD; Monitor- 22 inch	
21	Paper shredder	1
22	Desk Tray sets	2
23	Desk mounted pencil sharpeners	4
24	4-hole paper punches	4
25	Wastepaper baskets	2
26	Refrigerator 400 liters	1
27	Potable Water-cooler cum dispenser	1
28	Microwave oven (700W)	1
29	Cups, glasses, plates, cutlery for 12 persons,	2
30	Electric kettle, coffee, and tea pots	As required
31	Office consumables for the duration of site activities	As required
32	Front Door Mat	As required
33	Flashlight	1
34	Locker with Key (900x300x500)	For 10 Persons

Table B: Items for the exclusive use of the Engineer's/Employer's Staff at Resting Accommodation

No.	Item	Nos.
Furniture		
1	Double Bed with Side Table, Mattress, Bed Sheet, Pillow	2 sets
2	Single Bed with Side Table, Mattress, Bed Sheet, Pillow	6 sets
3	Sofa set with Centre Table for seating of 12 persons	1 set
4	2 Seater Sofa set with Centre Table	2 set
5	Dining Table	For 8 persons
6	Study table with side drawer and Chairs	4 Set
7	Visitor's Chair	16
8	3-Shelf Bookcase	1
9	Lockable Cupboard 2m high, with shelves.	2
10	White Board 2000x1000mm	1
11	TV set LED Screen 60"	1
12	Wall Clock	5
13	Coffee Machine	1
14	Cupboard Table height	1
15	Printer cum scanner cum Photocopier A4 (Canon, HP) capable of reduction	1
16	Desktop Computers (Dell, HP) with following configurations: Processor- i5 12 th GEN Intel; Operating System- Windows 11 Professional 64 bit; Video Card- intel; Memory- 16 GB Ram, DDR4; Hard Drive-1TB. SSD; Monitor- 22 inch	1

No.	Item	Nos.
17	Wifi internet connectivity with <i>at least</i> 100mbps	1
18	Refrigerator 400 liters	1
19	Potable Water-cooler cum dispenser	1
20	Kitchen Items	As required
21	Gas Stove	1
22	Domestic Cooking Gas Cylinder	2
23	Microwave oven (700W)	1
24	Cups, glasses, plates, cutlery for 12 persons,	2 set
25	Electric kettle, coffee, and tea pots	As required
26	Front Door Mat	As required
27	Flashlight	1
28	Dressing table	2

10.19.12 The Contractor shall provide 02 SUV type vehicles (*not older than 2022 initially*) for use of the *Employer's Staff* from the Commencement Date till completion of the Contract. *The vehicles shall be replaced after two years with vehicles of current make.* The Contractor shall also bear the expenditure of deploying experienced drivers along with fuel and other incidental expenses associated with the operation of the vehicle. *The approximate kilometers to be run every month will be 3000 km for each vehicle.* Only experienced drivers shall be deployed. *Vehicles along with drivers shall be made available round the clock throughout the Contract period.*

10.19.13 The Contractor shall provide brand new protective clothing and safety equipment for 30 persons for exclusive use of the *Engineer's /Employer's Staff*, comprising, as a minimum – Safety Helmets, Steel-toed construction boots (size to be notified), Gum boots, Day-Glo waistcoat, industrial safety goggles, Ear protectors. *These shall be replaced as and when required, however, they shall be replaced at least once a year. The consumables for PPE kit i.e mask, ear plugs etc. shall be supplied on daily basis.*

10.19.14 The Contractor shall provide an adjacent shaded parking area for 5 cars.

The Contractor shall arrange for upkeep, service and security of the offices and compound. The

office area shall be thoroughly cleaned and rubbish and waste to be removed, at least once a day as per current rules and regulations.

10.19.15 Communication System for Employer's/ Engineer's Staff

The Contractor shall provide seven sets of walkie talkie for use of Employer's /Engineer's staff. This shall include arrangement of licensing from concerned authorities and maintenance of the walkie talkies. In case of a walkie talkie set not being available due to any reason replacement shall be provided on real time basis by the Contractor.

Tender No. HORC/HRIDC/C-4/2022
Attachment 12
to
Corrigendum No. 3

Part 2, Section VII-9: Employer's
Requirements-Appendices

Appendix – 12/R2

Contractor's Site Laboratory

**APPENDIX 12/R2
CONTRACTOR'S SITE LABORATORY**

12. SITE LABORATORY

12.1 The Site Laboratory shall be approximately 250m² in area. It shall consist of the following accommodation:

1 concrete laboratory	60m ² floor area
1 Soil laboratory	30m ² floor area
2 office	each 15m ² floor area
1 store room	10m ² floor area
1 kitchen	10m ² floor area
Male & female toilets, changing room & shower	sufficient for 6 persons

12.2 The remainder of the 250m² shall consist of storage area for concrete cube curing tanks. The laboratory, office etc. shall be in one building; the curing tank storage building may be in a separate building, but if so, it shall be adjacent to the laboratory building & connected to it by a level, weatherproof passageway. In addition, an area of covered hard standing of 50m² for motor vehicles shall be provided adjacent to the laboratory.

12.3 STANDARD OF CONSTRUCTION

12.3.1 The laboratory shall be constructed to the best Engineering practice and as approved by the Engineer. Two independent telephone lines with two extensions each shall be provided for the laboratory. Telephones shall be located in areas as agreed with the Engineer.

12.3.2 A water tank with minimum capacity of 2000 litres shall be installed, as a source of constant water pressure (15 kPa minimum) for each laboratory.

12.3.3 In the case of sinks used for washing samples, adequate trapping and/or separating devices shall be provided to ensure the proper functioning of the facility.

12.4 FURNISHINGS AND FIXTURES

The contractor's site laboratory shall be provided with required furnishings and fixtures.

12.5 LABORATORY EQUIPMENT

12.5.1 The laboratory equipment, as listed below, shall be approved by the Engineer. The Contractor shall submit for the Engineer's approval within 2 weeks of the order to commence work the name of the supplier it intends to use for each piece of apparatus together with the relevant catalogue number. All the equipment shall be ISI marked. The list of equipment for earthwork shall be as per Annexure-VIII and Appendix -N of RDSO Specification No. RDSO/2020/GE:IRS-0004, September 2020. Equipment for concreting shall conform to specification given in relevant IS codes.

12.5.2 The layout of the equipment in the testing laboratory shall be instructed by the Engineer. The equipment shall be maintained to an accuracy appropriate to the required testing methods with routine calibration by an accredited organisation as recommended by the appropriate Authority. Equipment shall also be calibrated after maintenance or relocation.

12.5.3 The Contractor's site laboratory shall be equipped with the following material testing equipment as a minimum given in the below Table. The nature and quantity of equipment required for testing may be varied by the Engineer depending on the detail of the Contractor's Design and Construction methods or for any other reason which he deems to be valid and necessary for the proper control of quality:

S. No.	Description	Unit
1	Determining Liquid Limit	1 Set.
2	Liquid limit device (Casagrande type)	2 Set.
3	Cone penetrometer	2 Nos.
4	Grooving tools	3 Nos.
5	Evaporating dish	2 Nos.
6	Spatula 100mm blade	2 Nos.
7	Laboratory balance, capacity 500 gm, (Sensitivity 0.01 gms.)	1Nos.
8	Wash bottle, capacity 500 ml.	3 Nos.
9	Wash bottle, capacity 1 lit.	2 Nos.
10	Moisture cans, capacity 50 ml.	36 Nos.
11	Determining Plastic Limit (1 complete set) Glass plate 50cm x50cm x10 mm	3 Nos.
12	Stainless steel rods, 3 mm dia.	2 Nos.
13	Determining Moisture Content	1 Set.
14	Micro Oven- thermostatically controlled to maintain a temperature 105 to 110 °c.	1 Nos.
15	Electronic weighing machine capacity 200 gm., sensitivity 0.01 gm.	2 Set.
16	Lab. Tongs	1 Nos.
17	Moisture cans 75ml. with lid	36 Nos.
18	Compaction Characteristics	1 Set.
19	Standard compaction mould 100mm dia.	6 Nos.
20	Modified compaction mould 150mm dia.	6 Nos.
21	Standard compaction Rammer, 2.6 kg.	2 Nos.
22	Modified compaction Rammer, 4.89 kg.	2 Nos.
23	Straight edge 300mm long	2 Nos.
24	Sample ejector for 100mm and 150mm mould	2 Nos.
25	Sample tray 60 x 60 x 8 cm	10 Nos.
26	Wash bottle, 500 ml.	2 Nos.
27	Moisture cans 250 ml.	80 Nos.
28	Density of soil in-place by sand cone method	2 Set.
29	Sand density cone apparatus, 150mm	2 Nos.
30	Plate, 300mmx300mm with center hold 150mm	2 Nos.
31	Glass jug for sand cone	2 Nos.
32	Chisel 25mmx 150mm	6 Nos.
33	Hammer	6 Nos.
34	One-gallon field cans	24 Nos.
35	Sampling spoon	3 Nos.
36	Soft hairbrush	3 Nos.
37	Sieve Analysis	
38	Electric Sieve shaker (portable)	1 Unit

S. No.	Description	Unit
39	Coarse sieves In Sizes from 100mm to 10mm (As per IS 383 table no. 2)	1 Set.
40	Fine Sieves 10mm, 4.75mm, 2.63mm, 1.18mm, .600mm, .300mm, .150mm,each)Pans & Covers Specific Gravity and Absorption of Coarse AggregateWire basket, 200mm dia.Heavy duty suspension balance, 20 kg x 1 gm. with accessory for weight in water.	2 Set.
41	Suitable water container	1 Nos.
42	Unit Weight of Aggregate Balance, 100 kg. capacity with 10 gm precision	1 Nos.
43	Tamping rod 16mm diameter x 600mm long	3 Nos.
44	Measuring containers (3,10,15,30 liters) Flakiness and Elongation	1 each
45	Flakiness gauge, elongation index	2 Set.
46	Soundness Test	
47	Sodium sulphate	25 Kg.
48	Soaking tank	1 Nos.
49	Balance, Capacity 3 kg., Sensitivity 0.1 gm.	1 Set.
50	Sieves: Coarse	1 Set.
51	Fine	1 Set.
52	Concrete	
53	Buckets for concrete sampling	12 Nos.
54	Slump cone	12 Nos.
55	Tamping rod	12 Nos.
56	Base plate	12 Nos.
57	Mixing pan for concrete	2 Nos.
58	Scoop for general purpose	6 Nos.
59	Concrete thermometer	6 Nos.
60	Concrete cylinder mould, 150 mm * 300 mm;	30 each
61	150 mm * 200 mm	30 each
62	Concrete cube mould, 100 mm cube & 150 mm cube	10+100 each
63	Adjustable spanners for dismantling cube moulds	6 Nos.
64	Capping set	2 Nos.
65	Capping compound	As per requirement
66	Riffle	1 No.
67	Concrete curing tank with capacity for 270 cubes,	
68	temperature controlled, with circulation system drain and lockable cover	2 Nos.
69	Schmidt test hammer	1 Nos.
70	Compression testing machine (Fully automated)	1 Nos
71	Mould oil	
72	Temperature chart recorder	1 Nos.
73	Miscellaneous Vernier calipers to measure up to 200mm, with elongated jaws	5 Nos.
74	Steel rule, 300 mm long graduated	2 Nos.
75	Rubber gloves	10 pr.
76	Cotton working gloves	20 pr.
77	First aid kit	1 Set.
78	Wire brush	6 Nos.
79	Steel tape, 3m, 5m, 30m	3 each.

S. No.	Description	Unit
80	Ball peen hammer, 1 kg	2 Nos.
81	Paint scraper. Approx. 100mm wide	8 Nos.
82	Float, steel Approx.280 x 120 mm	8 Nos.
83	Sack barrow	1 Nos.
84	Shovel: Square Mouthed	2 Nos.
85	Round Mouthed	2 Nos.
86	24- wheel trolley, heavy duty, approx. 0.7m x 1.0m long pneumatic tyred type	2 Nos.
87	Wheelbarrow, rubber tyred	1 Nos.
88	Comprehensive tool kit. To include screwdrivers, pliers, claw hammer, multi-grips, spanners (adjustable)	1 Nos.
89	Type NR Schmidt Hammer and tester with recording device	1 Nos.
90	Testing Anvil for Schmidt Hammer test (SHT)	1 Nos.
91	Chart recording paper for SHT	10 pkts.
92	Cover meter for detecting metal objects to depth of 100mm below the surface of non-magnetic objects	3 Nos.
93	Noise meter	1 Nos.
94	RCPT Testing Machine with mould	1 Nos.
95	Permeability Testing Machine	1 Nos.
96	RAIN GAUGE	1 Set.
97	Loss angle abrasion machine	1 Set.
98	Mortar cube casting machine	1 Set.
99	Cement testing kit as per Is-4031	1 Set.
100	Nuclear Moisture Density Gauge (NMDG) Apparatus	2 Set.
101	Core cutter with dolly and hammer (as per appendix D of RDSO-004)	4 Set.
102	Torque wrench (500 N-m)	4 Nos.
103	SDA/SN bolt pull out testing equipment	2 Nos.
104	Swellex pull out equipment	1 Nos.
105	Anemometer	2 Nos.
106	Multi gas detector	2 Nos.
107	Lux meter	2 Nos.
108	Noise detector	2 Nos.
109	Alcohol detector	2 Nos.
110	Panels for shotcrete testing	2 Nos.
111	Shotcrete slab moulds (150x150x450)	12 Nos.
112	Penetrometer	1 Nos.

S. No	Consumable Item	Unit
1	Sieve brush Wire brush	
2	Sodium carbonate	
3	Sodium hexa meta phosphate.	
4	Kerosene Mercury	

S. No.	Additional Equipment	Unit
1	Hand auger 150mm dia with extension rod	
2	Sampling tube 100mm dia. And 450mm length	

Note: All machines and equipment should have Calibration Certificate.